

THIS DRAWING IS UNPUBLISHED. RELEASED FOR PUBLICATION 20  
 © COPYRIGHT 20 BY - ALL RIGHTS RESERVED.

REVISIONS				
P	LTR	DESCRIPTION	DATE	APVD
E1		REV PER ECO 14-002547	4-24-14	CT DM

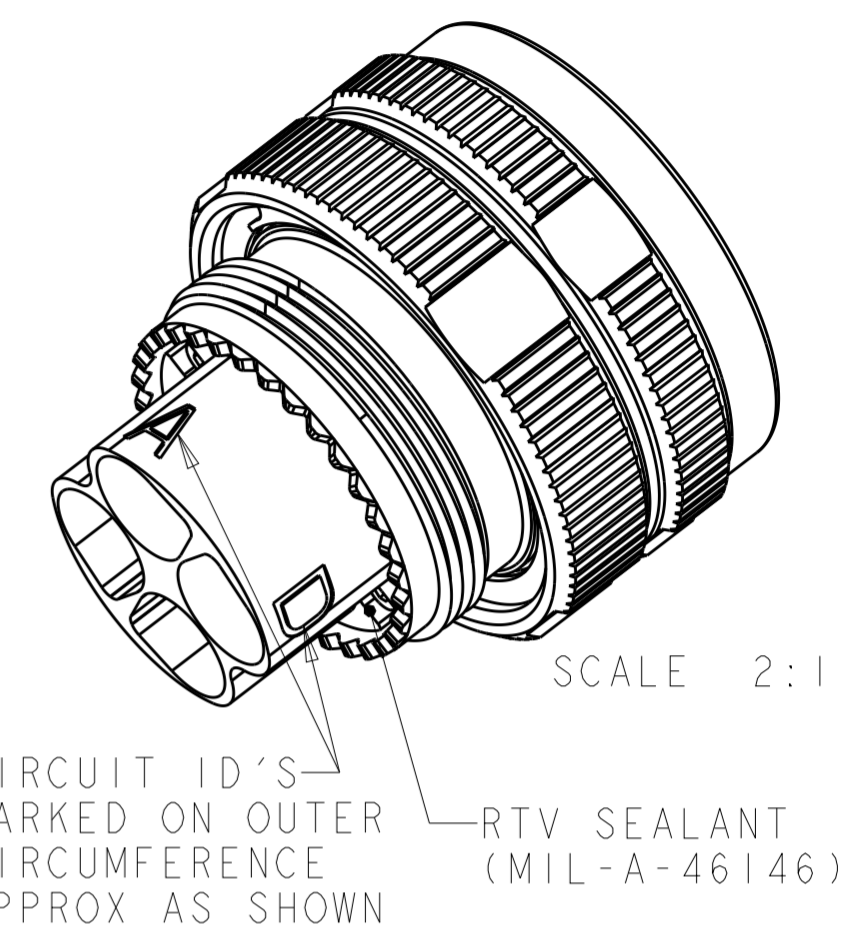
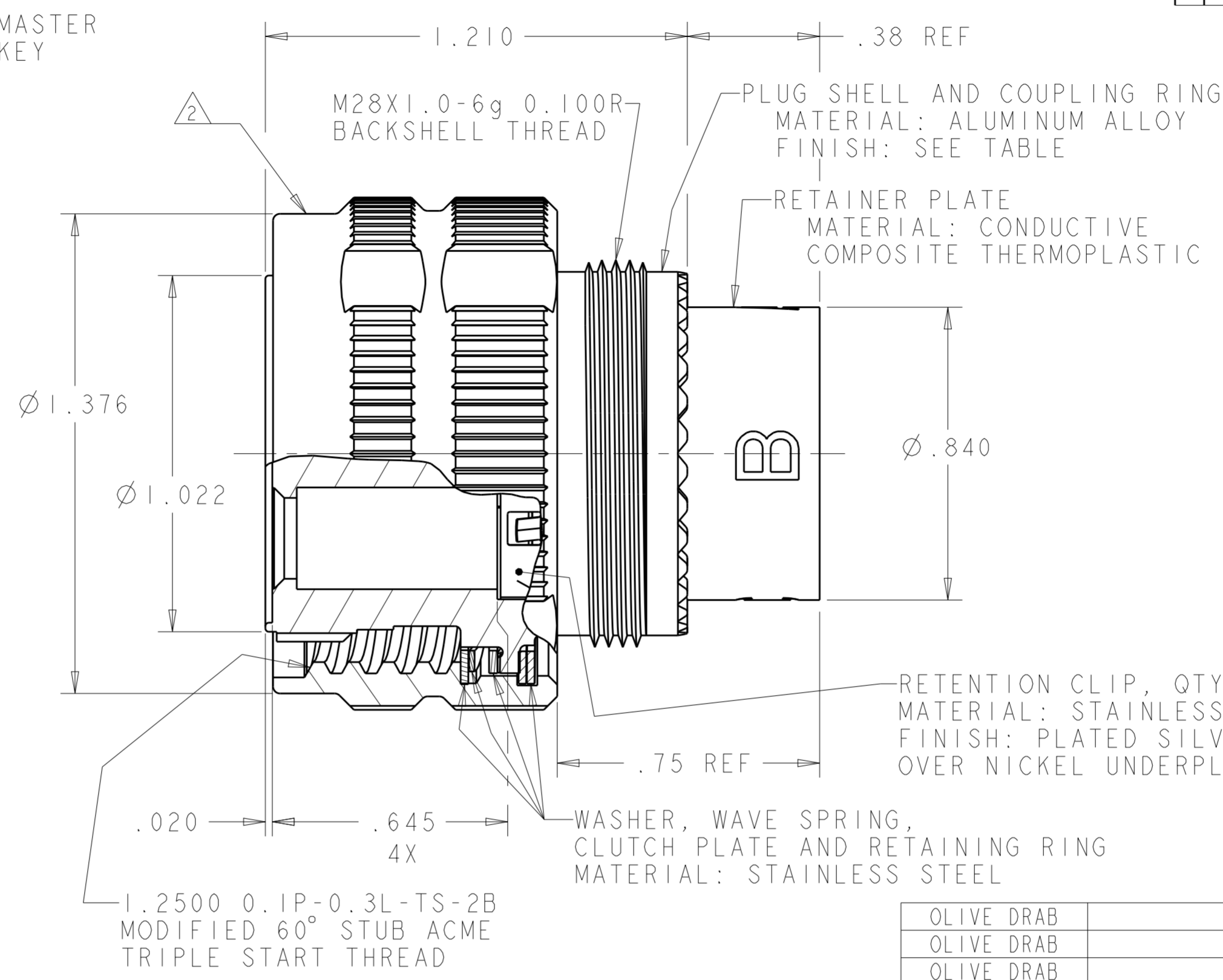
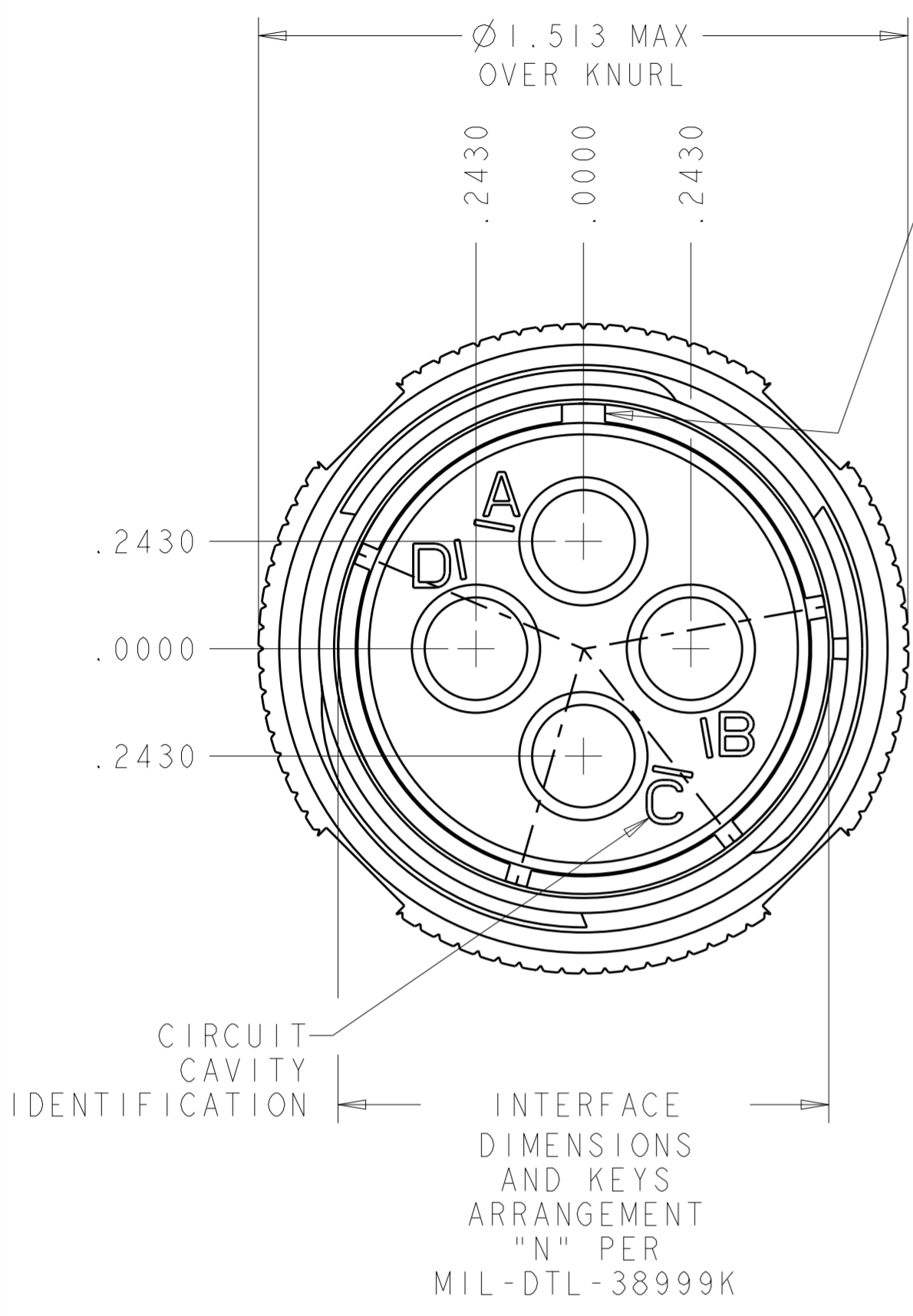

OLIVE DRAB	-	B	1-1811902-9
OLIVE DRAB	-	A	1-1811902-8
OLIVE DRAB	-	N	1-1811902-7
NICKEL	1877040-2	B	1-1811902-5
NICKEL	1877040-2	A	1-1811902-4
NICKEL	1877040-2	N	1-1811902-3
OLIVE DRAB	1445693-3	B	1-1811902-2
OLIVE DRAB	1445693-3	A	1-1811902-1
OLIVE DRAB	1445693-3	N	1-1811902-0
NICKEL	-	B	1811902-9
NICKEL	-	A	1811902-8
NICKEL	-	N	1811902-7
NICKEL	1445693-3	B	1811902-3
NICKEL	1445693-3	A	1811902-2
NICKEL	1445693-3	N	1811902-1
SHELL FINISH	QUADRAX CONTACT QTY=4	SHELL KEYING ARRANGEMENT	PART NUMBER

- THIS CONNECTOR ACCEPTS TYCO ELECTRONICS QUADRAX SOCKET ASSEMBLY; PART NUMBER 1445693-3 OR 1877040-2.
- PART IS MARKED WITH TE PART NO. (SEE TABLE), TE LOGO OR TE, TYCO ELECTRONICS CAGE CODE, AND DATE CODE.
- OPERATING TEMPERATURE RANGE: -65°C TO +125°C (-85°F TO +257°F).
- THE CONNECTOR QUALIFICATION WAS COMPLETED PER TYCO ELECTRONICS 108-2199. THE QUADRAX CONTACTS ARE QUALIFIED PER TYCO ELECTRONICS 108-2131. THE REFERENCE TEST REPORTS ARE TYCO ELECTRONICS 501-660 FOR THE CONNECTOR AND 501-574 FOR THE CONTACTS WHICH ARE SAME AS ARINC 600-13, DRAFT 2 OF SUPPLEMENT 14 (AIR TRANSPORT AVIONICS EQUIPMENT INTERFACES).

THIS DRAWING IS A CONTROLLED DOCUMENT.

DIMENSIONS: INCHES	TOLERANCES UNLESS OTHERWISE SPECIFIED:	DWN R FLAIG 02AUG2005	TE Connectivity
	0 PLC ±.1	CHK L OH 02AUG2005	
	1 PLC ±.01	APVD L OH 02AUG2005	
MATERIAL	FINISH	PRODUCT SPEC	NAME ASSY, PLUG, SIZE 19, 404, M38999 STYLE
		APPLICATION SPEC	SIZE A2 CAGE CODE - DRAWING NO. C-1811902 RESTRICTED TO -
		WEIGHT	SCALE 3:1 SHEET 1 OF 2 REV E1
		CUSTOMER DRAWING	

THIS DRAWING IS UNPUBLISHED. RELEASED FOR PUBLICATION 20  
 © COPYRIGHT 20 BY - ALL RIGHTS RESERVED.

REVISIONS				
P	LTR	DESCRIPTION	DATE	APVD
-	-	SEE SHEET 1	-	-

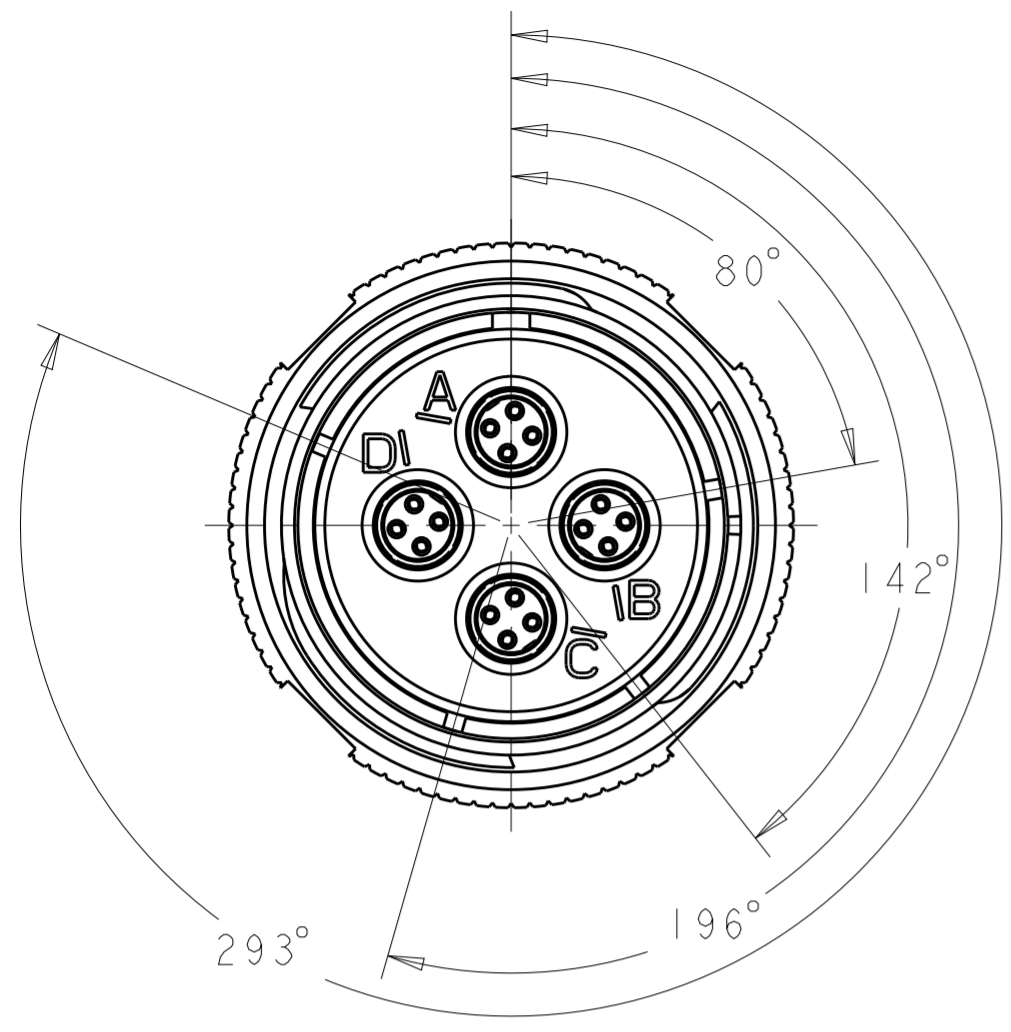

1811902-1  
"N" KEY POLARIZATION

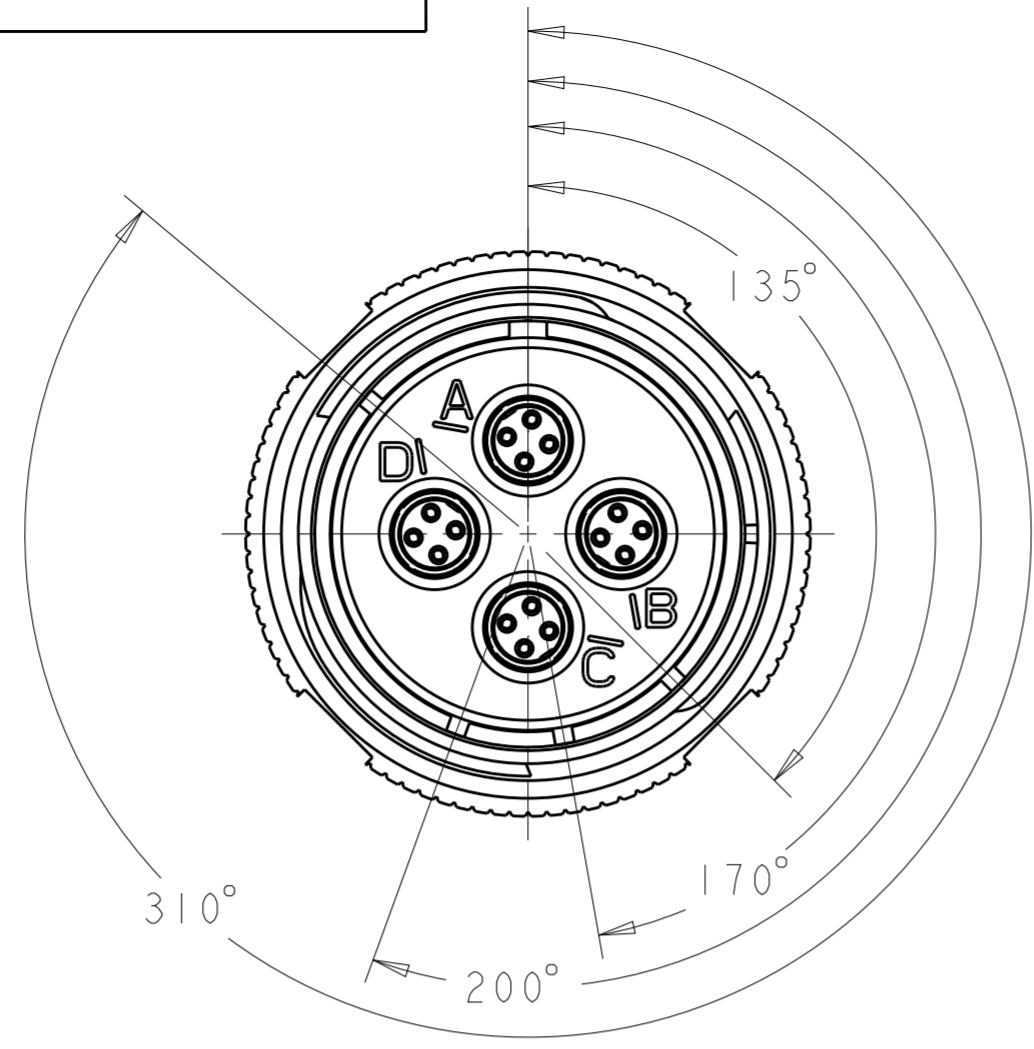

1811902-2  
"A" KEY POLARIZATION

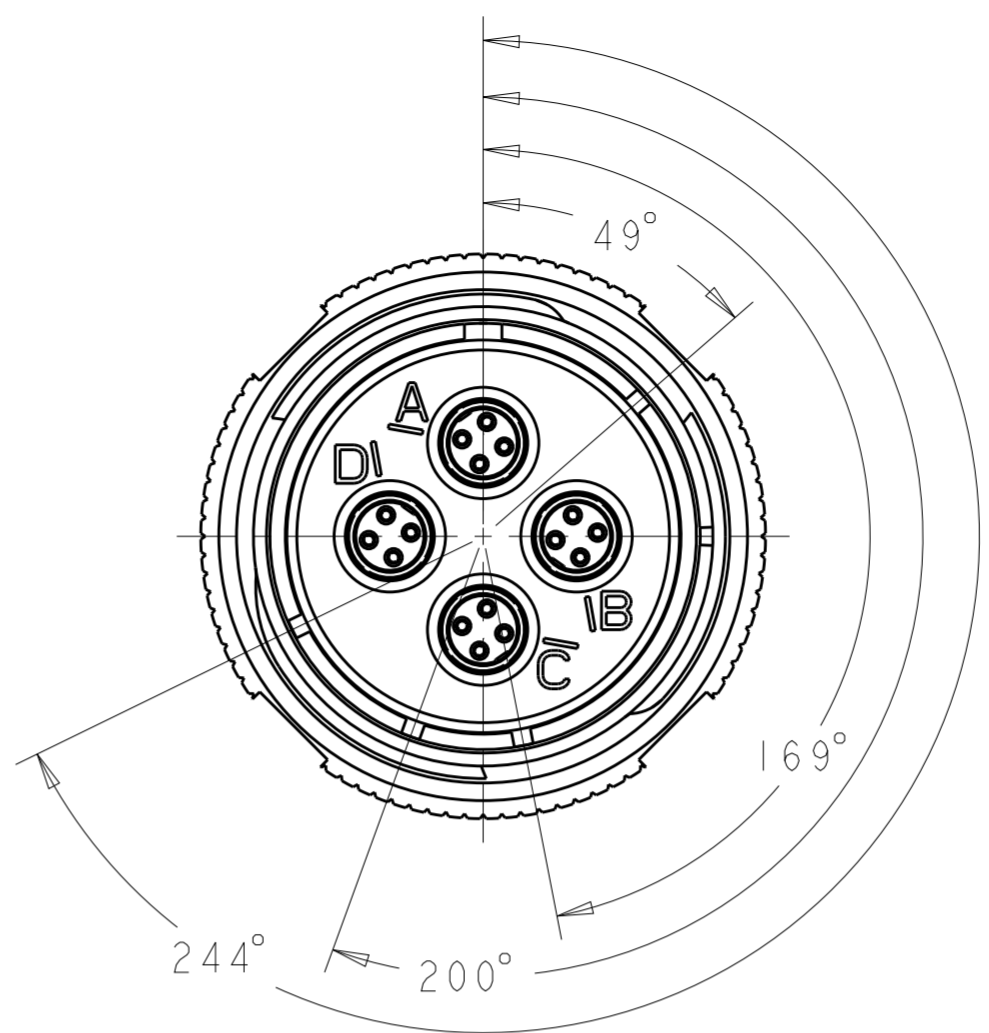

1811902-3  
"B" KEY POLARIZATION

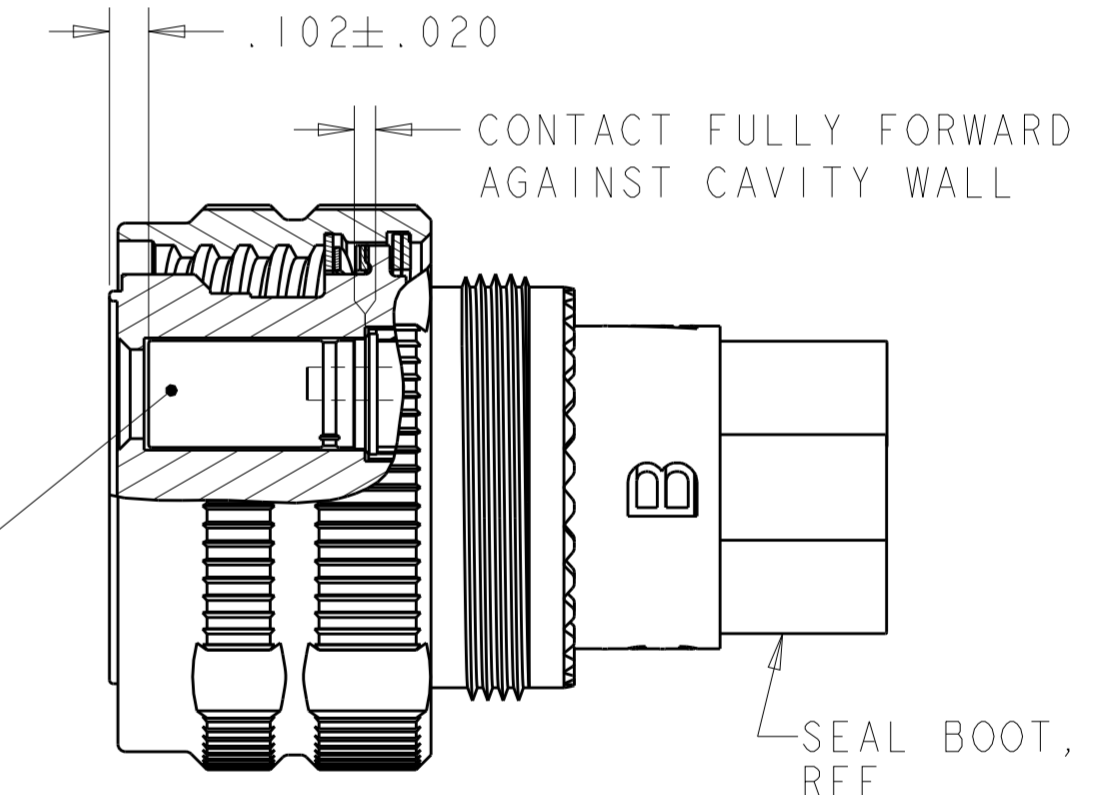
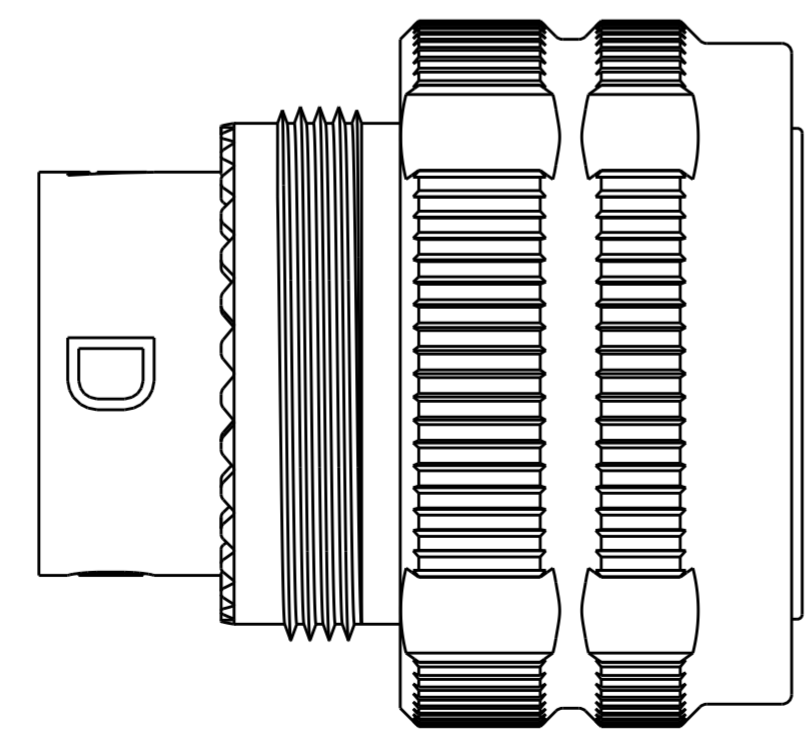
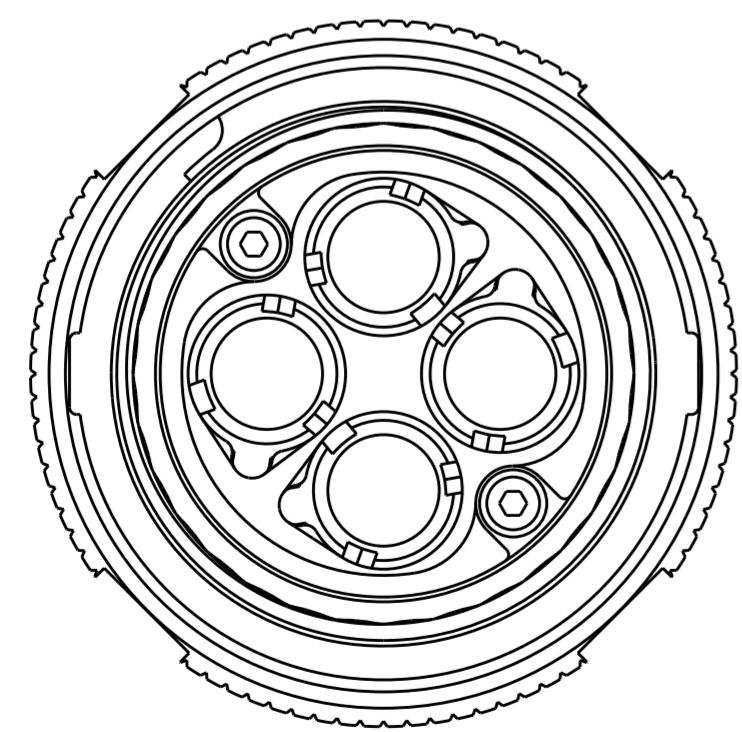

QUADRAX SOCKET ASSY,  
 SHOWN FOR REF ONLY  
 -1, -2, -3, -10, -11,  
 -12, -13, -14, & -15 CONTACT PROVIDED UN-ASSEMBLED  
 -7, -8, & -9 CONTACT SOLD SEPARATELY

SECTION Y-Y  
 SCALE 2:1

THIS DRAWING IS A CONTROLLED DOCUMENT.		DWN R FLAIG 02AUG2005	TE Connectivity			
DIMENSIONS: INCHES		CHK L OH 02AUG2005				
		APVD L OH 02AUG2005	NAME ASSY, PLUG, SIZE 19, 404, M38999 STYLE			
TOLERANCES UNLESS OTHERWISE SPECIFIED: 0 PLC ±.1 1 PLC ±.01 2 PLC ±.005 3 PLC ±.0020 4 PLC ±.0020 ANGLES ±1° FINISH		PRODUCT SPEC -	SIZE A2	CAGE CODE -	DRAWING NO G-1811902	RESTRICTED TO -
MATERIAL -		APPLICATION SPEC -	WEIGHT -	SCALE 3:1	SHEET 2 OF 2	REV E1
CUSTOMER DRAWING						