

Solder Instruction

1. Cable should be prepared for soldering. The cable/wires must be pretinned.
2. Insert cable/wire into solder cup
3. Operate the soldering iron at 350°C, 50 Watt max. and use a pencil tip.
4. Apply some solder to the solder tip of the soldering iron.
5. Put tip to wire in solder cup
6. After 1 second bring in solder.
7. Heat for 3 seconds longer. Do not heat contact more than 6 seconds in total.
8. Remove soldering iron.
9. Wait until solder gets rigid again.
10. Do not solder adjacent contacts consecutively, alternate position within the connector to minimize heat build up.

(5:1)

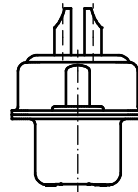
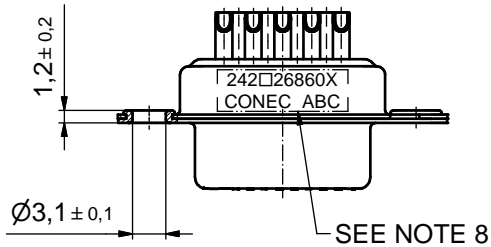
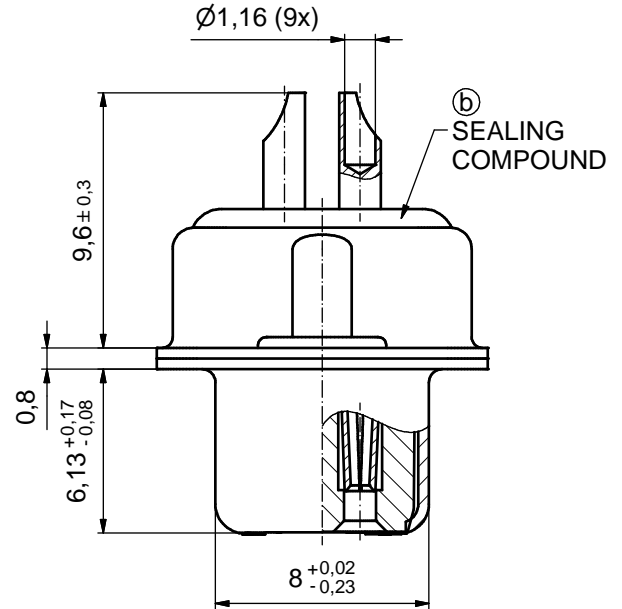
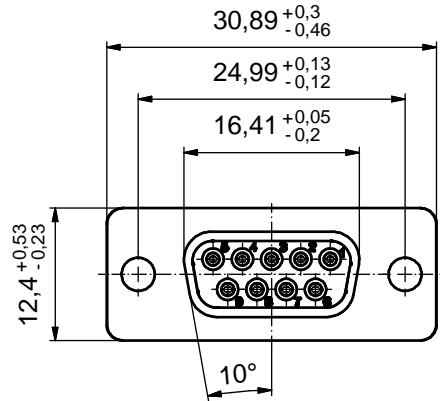

NOTES:

1. RoHS COMPLIANT
2. METALSHELLS: STEEL; min. 315µm TIN over 40-80µm NICKEL
3. INSULATOR: HIGH TEMPERATURE PLASTIC UL 94 V-0; BLACK
4. CONTACTS: COPPER ALLOY; PLATING (SEE PART-NO.):
 - PLEASE ADD A for GOLD FLASH over NICKEL (PREFERRED TYPE)
 - PLEASE ADD B for 20µm HARD GOLD over min. 50µm NICKEL
 - PLEASE ADD C for 30µm HARD GOLD over min. 50µm NICKEL
5. SEALING COMPOUND: PUR; BLUE
6. CAPACITANCE: 1300 pF ± 20%
7. DIELECTRIC WITHSTANDING VOLTAGE: 424 VDC
8. CONNECTOR IS PART MARKED: **242□26860X CONEC ABC** (see note 4)

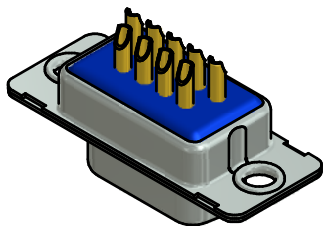

RoHS compliant

THIS DRAWING MAY NOT BE COPIED OR REPRODUCED IN ANY WAY, AND MAY NOT BE PASSED ON TO A THIRD PARTY WITHOUT WRITTEN PERMISSION. OWNERSHIP AND COPYRIGHT OF CONEC GmbH				tolerance		dim. in mm	scale: 2:1 (5:1)		
				date			material: SEE NOTES		
DO NOT ALTER CAD DRAWING BY HAND				drawn	03.02.06	Lehmenkühler	title: D-SUB C-FILTER FEMALE 9pos. SOLDER CUP		
				appd.	03.02.06	Mickenbecker			
2 x b Ä6143 24.05.2016 Lehm.				norm	DIN 41652				dwg no:
				rev.	description	date	name	d-old	
				CONEC ®		part no: 242□26860X (see note 4)			
						24K1A757			