

THIS DRAWING IS UNPUBLISHED. RELEASED FOR PUBLICATION, 19 .
 © COPYRIGHT 19 BY AMP INCORPORATED. ALL INTERNATIONAL RIGHTS RESERVED.

LOC	DIST	P	F	ZONE	LTR	DESCRIPTION	DATE	APPD
AF	50				A	RELEASED PER FASR AND 0L10-0066-96	29/AUG/96	PF/GY

1 CONTINUOUS STRIP ON REEL.

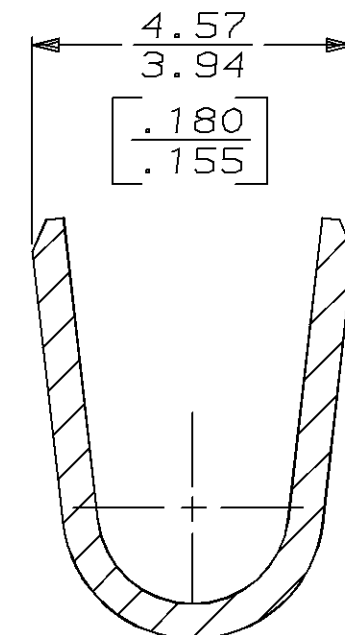
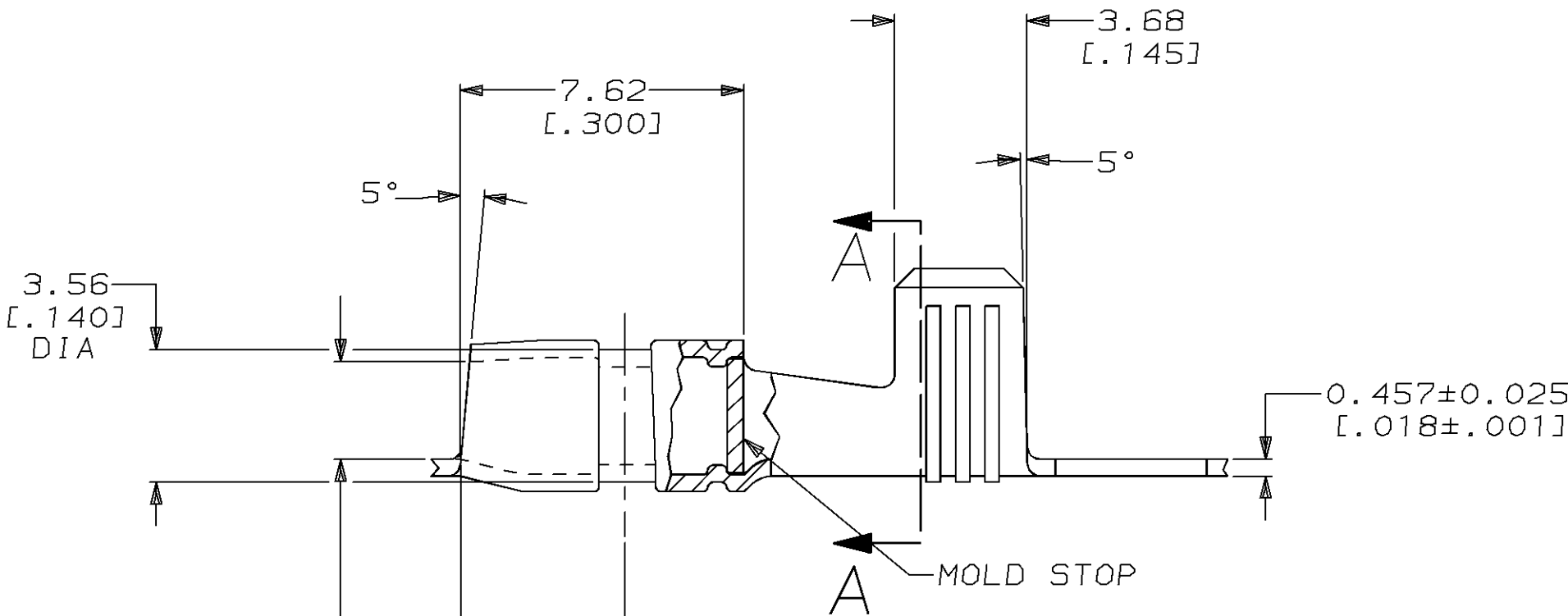
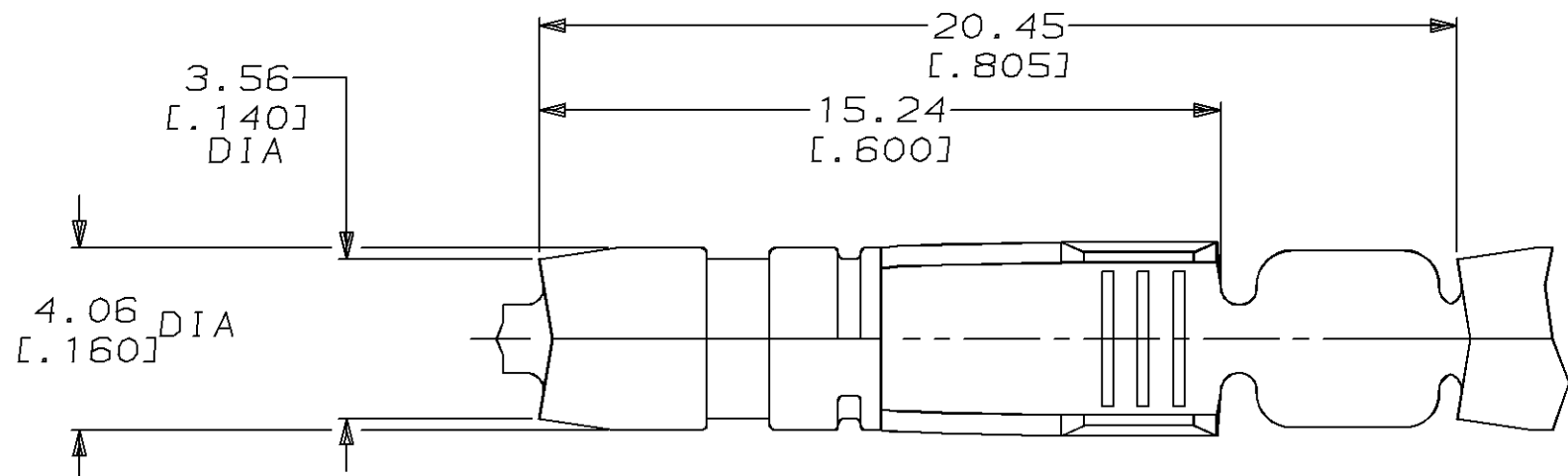

SECTION A-A
SCALE 10:1

2.44±0.10
[.096±.004]
DIA

[12] OR [14] AWG	63925-1
WIRE RANGE	PART NO

DO NOT SCALE PRINT, UNLESS SPECIFIED DIMENSIONS IN mm [INCHES] TOLERANCES ON: 2 PLC DEC ± 0.25 [.010] 3 PLC DEC ± - ANGLES ± 1°	DR 22/JUL/96 PHILLIP M. FORTNEY
	CHK 22/JUL/96 JEFF R. RUTH
	APPD 22/JUL/96 GARY YETTER
	APPD 22/JUL/96 MARK BARNABA
MATERIAL 081 BRASS	PRODUCT SPEC -
FINISH 0.003302 [.000130] MAX PRE-TIN PL PER MIL-T-10727	APPLICATION SPEC - WEIGHT -

AMP AMP Incorporated Harrisburg, PA 17105-3608		
NAME SHUR PLUG, 3.96 [.156] DIA		
SIZE B	CAGE CODE 00779	DRAWING NO C-63925
SCALE 6:1	SHEET 1 OF 1	

THIS DRAWING IS A CONTROLLED DOCUMENT FOR AMP INCORPORATED. IT IS SUBJECT TO CHANGE AND THE CONTROLLING ENGINEERING ORGANIZATION SHOULD BE CONTACTED FOR THE LATEST REVISION.