

THIS DRAWING IS UNPUBLISHED. RELEASED FOR PUBLICATION
 © COPYRIGHT - By - ALL RIGHTS RESERVED.

LOC	DIST	REVISIONS			
P	LTR	DESCRIPTION	DATE	DWN	APVD
G	14	B	REVISED PER ECO-10-012870	27APR11	HMR DR

AMP
WIRE RANGE

26-22 AWG
SOLID OR STRANDED

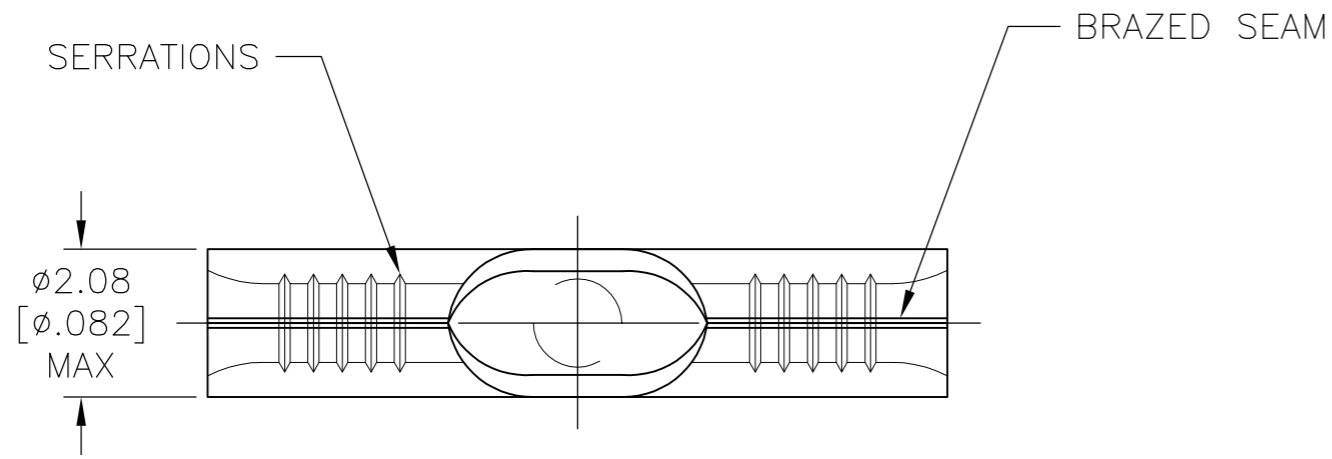

- 1 STAMP AMP APPROX AS SHOWN
- 2 MAXIMUM LENGTH DOES NOT INCLUDE MANUFACTURING TABS
- 3 COPPER PER ASTM B-152, ANNEALED
- 4 GOLD PLATE 0.00127[0.000050]MIN EXT THK PER ASTM B488 TYPE 1, CODE C OVER
NICKEL PLATE 0.00127[0.000050]MIN EXT THK PER SAE AMS QQ-N-290 OVER Cu FLASH PER SAE AMS 2418.

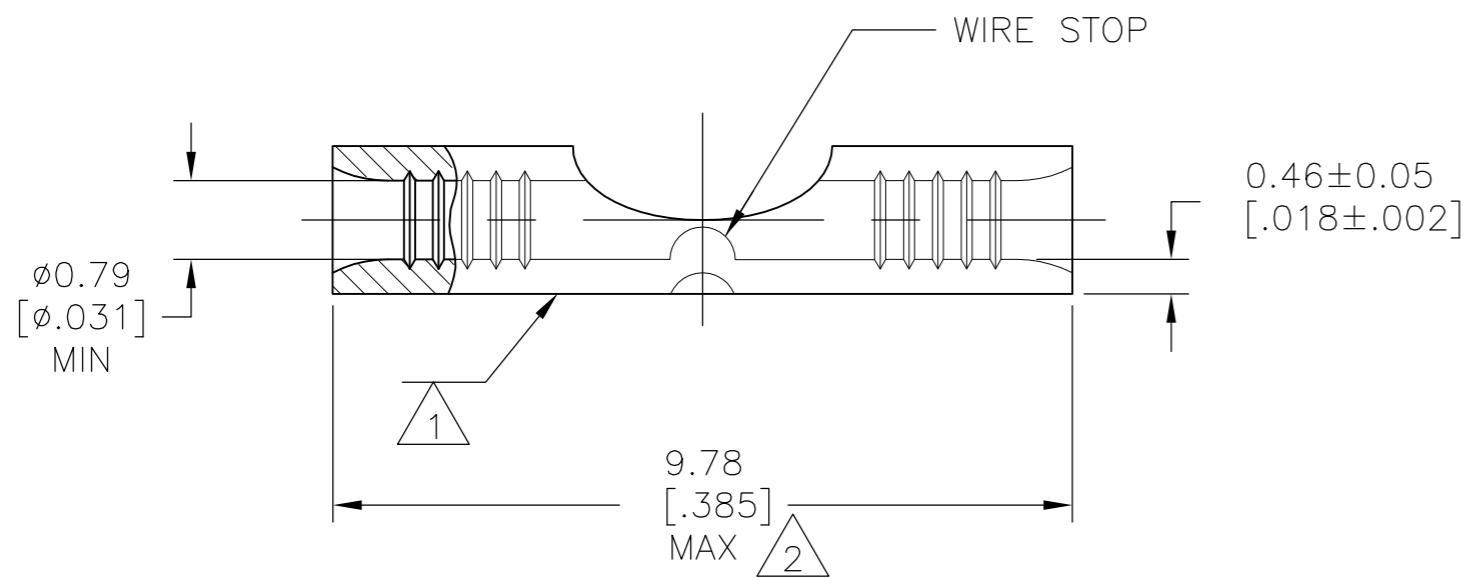

1000	LOOSE PIECE	324369
QTY	PACKAGING	PART NO.

AMP INCORPORATED CUSTOMER SERVICE SYSTEMS		MAX RECOMMENDED OPERATING TEMPERATURE: 260°C
FOR ADDITIONAL PRODUCT INFORMATION OR COPIES OF DRAWINGS AND TECHNICAL DOCUMENTS	PRODUCT INFORMATION CENTER 1-800-522-6752	VOLTAGE RATING: N/A
FOR APPLICATION TOOLING INFORMATION	TOOLING ASSISTANCE CENTER 1-800-722-1111	CIRCULAR MIL AREA: 0.1-0.41mm ² [202-810] SOLID OR STRANDED
FOR ORDER ENTRY	1-800-526-5142	THIS DRAWING IS A CONTROLLED DOCUMENT FOR AMP INCORPORATED. IT IS SUBJECT TO CHANGE AND THE CONTROLLING ENGINEERING ORGANIZATION SHOULD BE CONTACTED FOR THE LATEST REVISION.

THIS DRAWING IS A CONTROLLED DOCUMENT.		DWN TA BRINKMAN 6-15-93	TE TE Connectivity		
DIMENSIONS: mm [INCHES]		CHK DA PATTERSON 6-15-93			
TOLERANCES UNLESS OTHERWISE SPECIFIED:		APVD JL MECKLEY 6-15-93	NAME SPLICE, BUTT, STRAP, SOLISTRAND, HEAT RESISTANT,		
0 PLC ± - 1 PLC ± - 2 PLC ± - 3 PLC ± - 4 PLC ± - ANGLES ± ±		PRODUCT SPEC APPLICATION SPEC	SIZE A2	CAGE CODE 00779	DRAWING NO C=324369
MATERIAL 3	FINISH 4	WEIGHT -	SCALE 10:1	SHEET 1 of 1	REV B
CUSTOMER DRAWING					