

SECTION Z-Z

NOTE:
 1.MATERIAL:
 HOUSING : LCP - UL94V-0, COLOR: BLACK
 CONTACTS : COPPER ALLOY
 LOCK LEVER : STAINLESS STEEL

2.FINISHES:
 CONTACT AREA : REFER TABLE IN SHEET 6.
 SOLDER TAIL AREA : REFER TABLE IN SHEET 6.
 LOCK LEVER SOLDER PAD : 100 MICRINCH / 2.54 MICROMETER MATTE TIN OVER 50 MICRINCH / 1.27 MICROMETER NICKEL.

3.RECOMMENDED MODULE LAYOUT SHALL BE AS PER JEDEC MO-268

4.PRODUCT SPECIFICATION : REFER TABLE IN SHEET 6

5.PACKAGING SPECIFICATION: PART SHALL BE PACKED IN TRAY OR TAPE AND REEL.

6.EDGE OF CONTACT PADS SHALL BE FREE OF BURRS AND EXTERNAL TIE BARS.

7.THE ADDITION OF THIS BEVEL IS A FABRICATION OPTION AND IS NOT REQUIRED. THE BEVEL AIDS THE INSERTION OF THE MODULES INTO THE CONNECTOR. THE BEVEL MUST NOT ENCORACH ONTO GOLD OADS.

8.COPLANARITY INCLUDES HOLD DOWN 0.1 MAX.

CUST REQ DIM ADD EC NO: S2010-0146 DRWN:VMANICKAM CHKD:CCTEH APPR:SHLENI	2009/08/18 2009/08/20 2009/08/20	QUALITY SYMBOLS ▽=0 ◻=0	GENERAL TOLERANCES (UNLESS SPECIFIED)		DIMENSION STYLE	SCALE	DESIGN UNITS	THIRD ANGLE PROJECTION		
					MM ONLY	NTS	METRIC			
			mm	INCH	DRAWN BY	DATE	TITLE			
			4 PLACES	± ---	± ---	CMTEO	2007/03/16	DDR3 SO DIMM		
3 PLACES	± ---	± ---	CHECKED BY	DATE	204 CKTS, 5.2MM HEIGHT					
2 PLACES	± 0.2	± ---	VMANICKAM	2007/04/23	REVERSE ORIENTATION					
1 PLACE	± ---	± ---	APPROVED BY	DATE	MOLEX INCORPORATED					
ANGULAR ± 1 °				SHLENI	2007/04/23	DOCUMENT NO.				
DRAFT WHERE APPLICABLE MUST REMAIN WITHIN DIMENSIONS				SEE TABLE		SD-78279-001		SHEET NO.		
				SIZE	THIS DRAWING CONTAINS INFORMATION THAT IS PROPRIETARY TO MOLEX INCORPORATED AND SHOULD NOT BE USED WITHOUT WRITTEN PERMISSION					
				A3						

RECOMMENDED MATING PCB CONFIGURATION

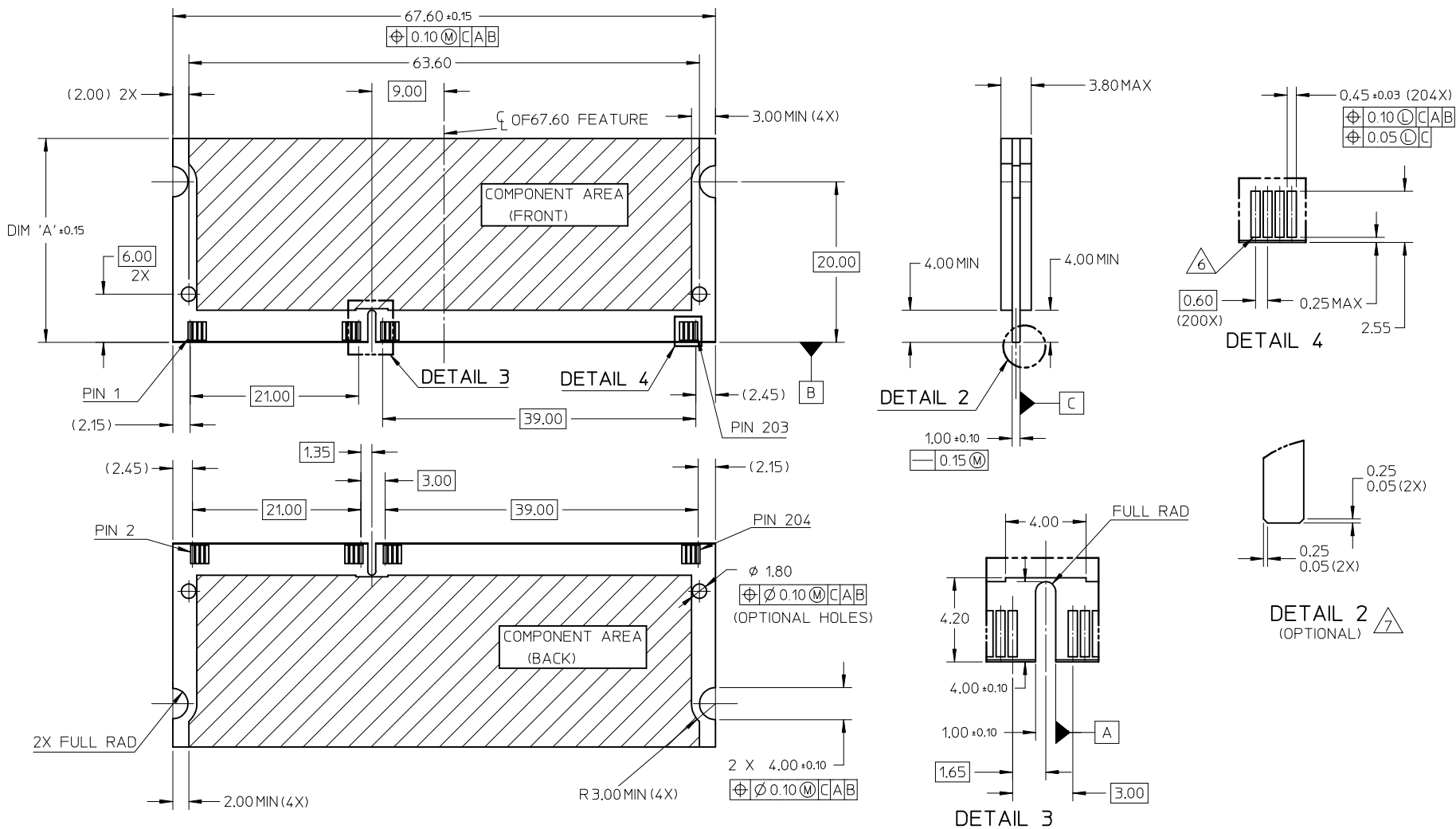

SDRAM VARIATION FROM JEDEC MO-268			
	AA	BB	CC
DIM 'A'	25.40	31.75	30.00

CUST REQ DIM ADD EC NO: S2010-0146 DRWN:VMANICKAM 2009/08/18 CHKD:CCTEH 2009/08/20 APPR:SHLENI 2009/08/20	QUALITY SYMBOLS	GENERAL TOLERANCES (UNLESS SPECIFIED)		DIMENSION STYLE	SCALE	DESIGN UNITS	THIRD ANGLE PROJECTION
	▽=0 Ⓢ=0	mm	INCH	MM ONLY	NTS	METRIC	
		4 PLACES ± --- ± ---	3 PLACES ± --- ± ---	DRAWN BY	DATE	TITLE	
		2 PLACES ± 0.2 ± ---	1 PLACE ± --- ± ---	CHECKED BY	DATE	DDR3 SO DIMM 204 CKTS, 5.2MM HEIGHT REVERSE ORIENTATION	
	ANGULAR ± 1 °			APPROVED BY	DATE	MOLEX INCORPORATED	
		DRAFT WHERE APPLICABLE MUST REMAIN WITHIN DIMENSIONS		MATERIAL NO.	DOCUMENT NO.	SHEET NO.	
B4	REV			SIZE	THIS DRAWING CONTAINS INFORMATION THAT IS PROPRIETARY TO MOLEX INCORPORATED AND SHOULD NOT BE USED WITHOUT WRITTEN PERMISSION		

10 9 8 7 6 5 4 3 2 1

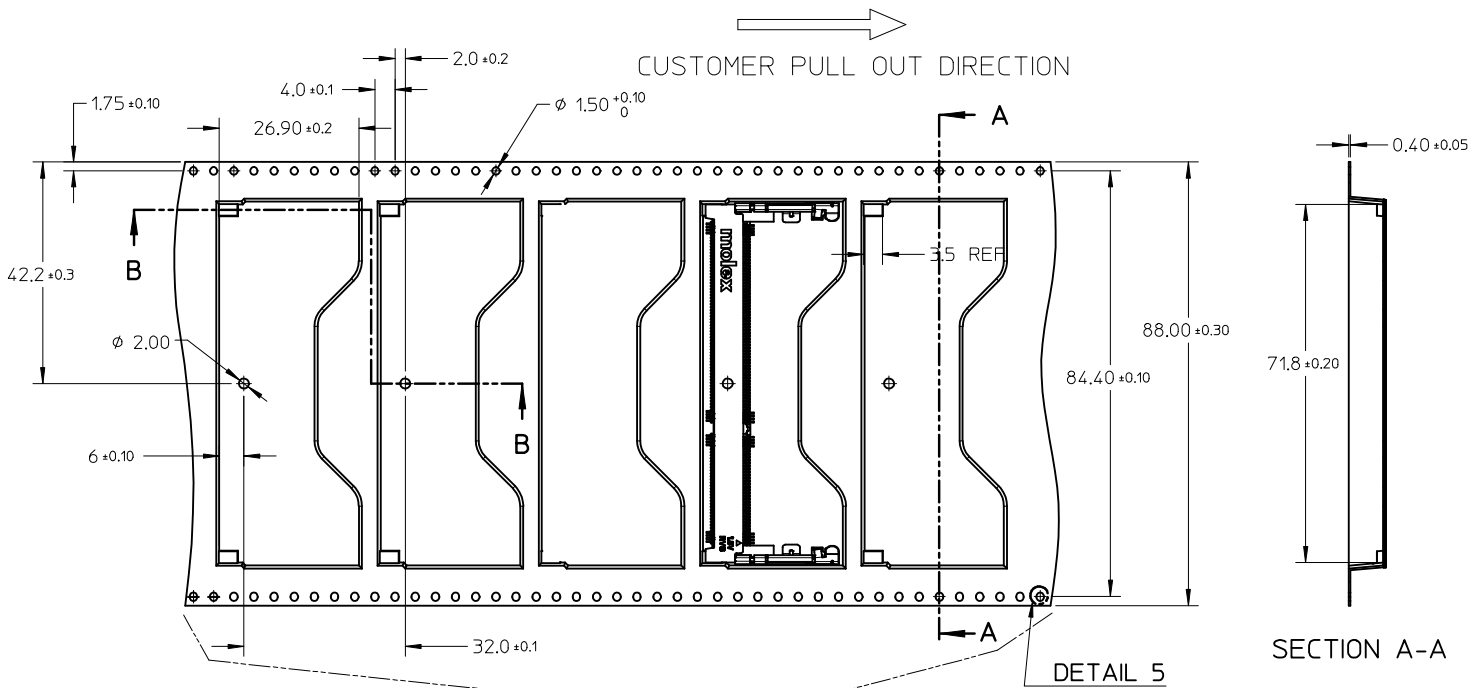

NOTES:

1. LEADER AND TRAILER TAPE

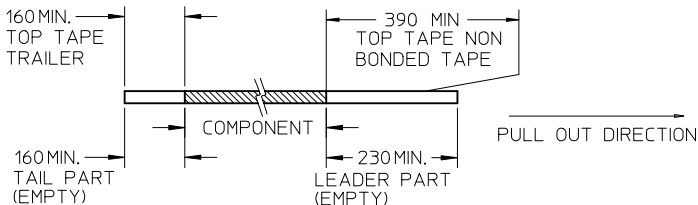

2. PEELING OFF FORCE OF THE TOP TAPE: 10 - 150gf. (PEELING DIRECTION AS SHOWN IN FOLLOWING FIGURE)

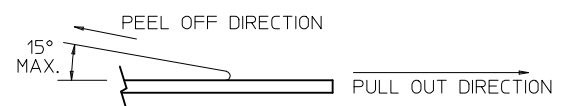

- 3. TAPE AND REEL SPECIFICATION IS AS PER EIA-481.
- 4. TAPE AND REEL QUANTITY : 200 PCS/ REEL.
- 5. THE TAPE IS TREATED FOR ANTI-STATIC.

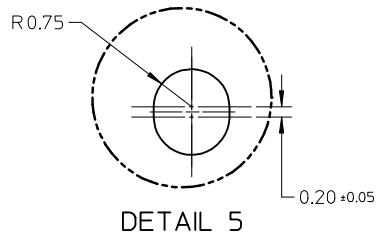
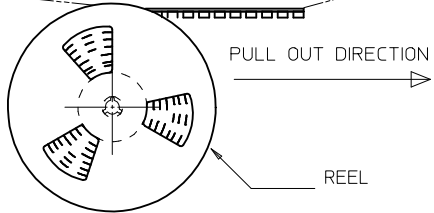

CUST REQ DIM ADD
 EC NO: S2010-0146
 DRWN:VMANICKAM 2009/08/18
 CHKD:CCTEH 2009/08/20
 APPR:SHLENI 2009/08/20

QUALITY SYMBOLS	DESCRIPTION
▽=0	
∇=0	

GENERAL TOLERANCES (UNLESS SPECIFIED)	
	mm INCH
4 PLACES	± --- ± ---
3 PLACES	± --- ± ---
2 PLACES	± 0.2 ± ---
1 PLACE	± --- ± ---
ANGULAR ± 1 °	
DRAFT WHERE APPLICABLE MUST REMAIN WITHIN DIMENSIONS	

DIMENSION STYLE	
MM ONLY	
DRAWN BY	DATE
CMTEO	2007/03/16
CHECKED BY	DATE
VMANICKAM	2007/04/23
APPROVED BY	DATE
SHLENI	2007/04/23
MATERIAL NO.	
SEE TABLE	
SIZE	
A3	

SCALE	DESIGN UNITS	THIRD ANGLE PROJECTION	
NTS	METRIC		
TITLE			
DDR3 SO DIMM			
204 CKTS, 5.2MM HEIGHT			
REVERSE ORIENTATION			
MOLEX INCORPORATED			
DOCUMENT NO.	SD-78279-001		SHEET NO.
			4 OF 6
THIS DRAWING CONTAINS INFORMATION THAT IS PROPRIETARY TO MOLEX INCORPORATED AND SHOULD NOT BE USED WITHOUT WRITTEN PERMISSION			

9 8 7 6 5 4 3 2 1

10 9 8 7 6 5 4 3 2 1

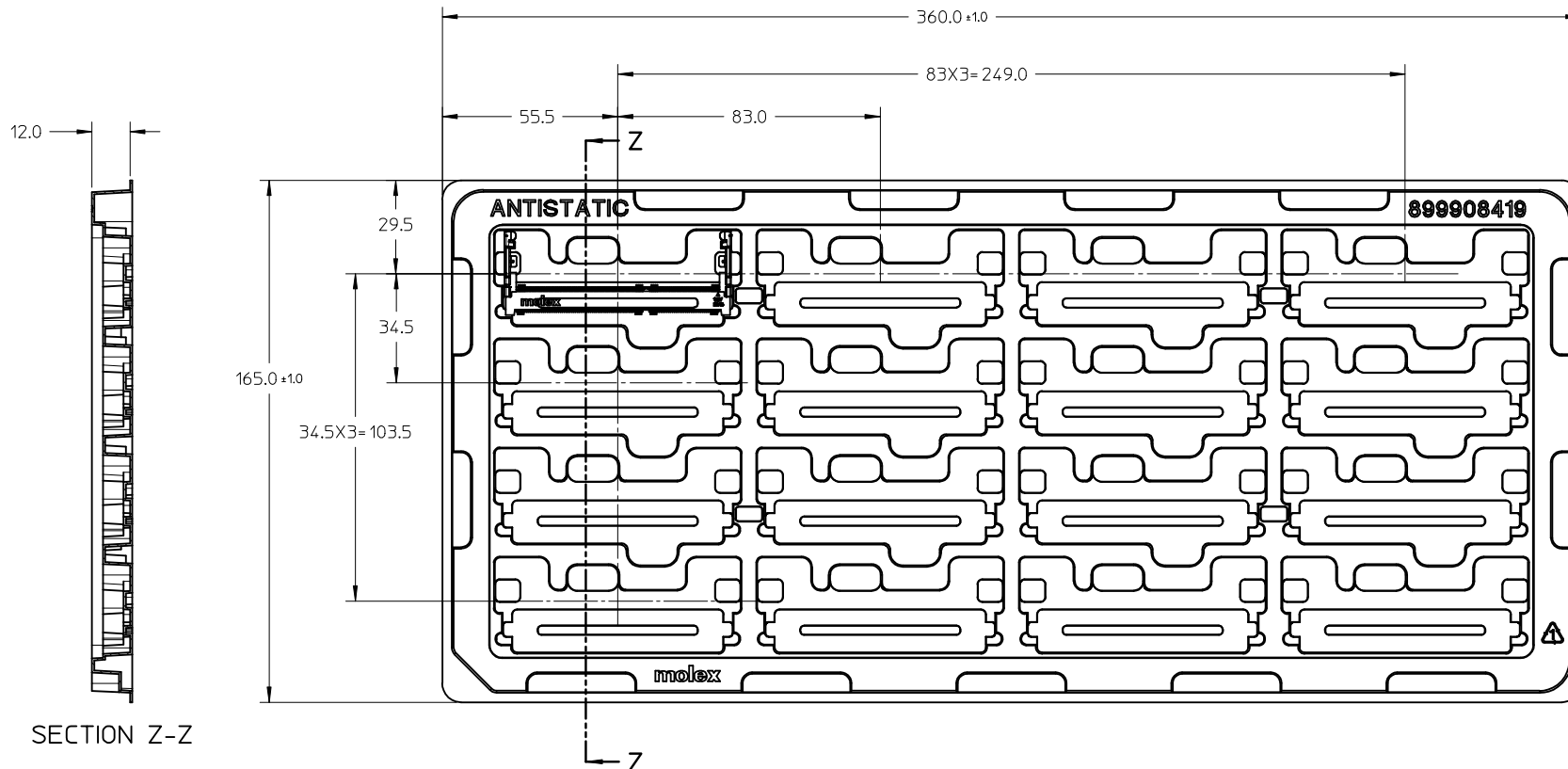

SECTION Z-Z

NOTES:

- 1. NO OF CAVITY : 4 X 4 = 16
- 2. UNSPECIFIED TOLERANCE FOR TRAY ±0.5

CUST REQ DIM ADD EC NO: S2010-0146 DRWN:VMANICKAM 2009/08/18 CHKD:CCTEH 2009/08/20 APPR:SHLENI 2009/08/20	DESCRIPTION REV	QUALITY SYMBOLS	GENERAL TOLERANCES (UNLESS SPECIFIED) mm INCH 4 PLACES ± --- ± --- 3 PLACES ± --- ± --- 2 PLACES ± 0.2 ± --- 1 PLACE ± --- ± --- ANGULAR ± 1 °	DIMENSION STYLE	SCALE	DESIGN UNITS	THIRD ANGLE PROJECTION
		▼=0 □=0		MM ONLY	NTS	METRIC	
				DRAWN BY	DATE	TITLE	
				CHECKED BY	DATE	DDR3 SO DIMM 204 CKTS, 5.2MM HEIGHT REVERSE ORIENTATION	
				APPROVED BY	DATE	MOLEX INCORPORATED	
				SHLENI	2007/04/23	MOLEX INCORPORATED	
				MATERIAL NO.	DOCUMENT NO.		SHEET NO.
				SEE TABLE	SD-78279-001		5 OF 6
				SIZE	THIS DRAWING CONTAINS INFORMATION THAT IS PROPRIETARY TO MOLEX INCORPORATED AND SHOULD NOT BE USED WITHOUT WRITTEN PERMISSION		
				A3			

9 8 7 6 5 4 3 2 1

PART NO	CONTACT AREA FINISH	SOLDER TAIL FINISH	PACKAGING	PRODUCT SPECIFICATION
78279-0001	3μN GOLD OVER 50μN/1.27μM NICKEL	100 MICROINCH /2.54 MICROMETER MATTE TIN OVER 50 MICEOINCH / 1.27 MICROMETER.	TRAY (360X165MM)	PS-78279-003
78279-1501	15μN/0.38μM GOLD OVER 50μN/1.27μM NICKEL			PS-78279-002
78279-3001	30μN/0.76μM GOLD OVER 50μN/1.27μM NICKEL			PS-78279-001
78279-0002	3μN GOLD OVER 50μN/1.27μM NICKEL	GOLD FLASH OVER 50μN/1.27μM NICKEL.		PS-78279-003
78279-1502	15μN/0.38μM GOLD OVER 50μN/1.27μM NICKEL			PS-78279-002
78279-3002	30μN/0.76μM GOLD OVER 50μN/1.27μM NICKEL			PS-78279-001
78279-0011	3μN GOLD OVER 50μN/1.27μM NICKEL	100 MICROINCH /2.54 MICROMETER MATTE TIN OVER 50 MICEOINCH / 1.27 MICROMETER.	TAPE&REEL	PS-78279-003
78279-1511	15μN/0.38μM GOLD OVER 50μN/1.27μM NICKEL			PS-78279-002
78279-3011	30μN/0.76μM GOLD OVER 50μN/1.27μM NICKEL			PS-78279-001
78279-0012	3μN GOLD OVER 50μN/1.27μM NICKEL	GOLD FLASH OVER 50μN/1.27μM NICKEL.		PS-78279-003
78279-1512	15μN/0.38μM GOLD OVER 50μN/1.27μM NICKEL			PS-78279-002
78279-3012	30μN/0.76μM GOLD OVER 50μN/1.27μM NICKEL			PS-78279-001

CUST REQ DIM ADD EC NO: S2010-0146 DRWN:VMANICKAM 2009/08/18 CHKD:CCTEH 2009/08/20 APPR:SHLENI 2009/08/20	QUALITY SYMBOLS	GENERAL TOLERANCES (UNLESS SPECIFIED)	DIMENSION STYLE MM ONLY	SCALE NTS	DESIGN UNITS METRIC	THIRD ANGLE PROJECTION	
	▼=0 □=0	mm INCH 4 PLACES ± --- ± --- 3 PLACES ± --- ± --- 2 PLACES ± 0.2 ± --- 1 PLACE ± --- ± --- ANGULAR ± 1 °	DRAWN BY DATE CMTEO 2007/03/16 CHECKED BY DATE VMANICKAM 2007/04/23 APPROVED BY DATE SHLENI 2007/04/23	TITLE DDR3 SO DIMM 204 CKTS, 5.2MM HEIGHT REVERSE ORIENTATION			
		DRAFT WHERE APPLICABLE MUST REMAIN WITHIN DIMENSIONS	MATERIAL NO. SEE TABLE	MOLEX INCORPORATED		DOCUMENT NO. SD-78279-001	SHEET NO. 6 OF 6
	B4			SIZE A3	THIS DRAWING CONTAINS INFORMATION THAT IS PROPRIETARY TO MOLEX INCORPORATED AND SHOULD NOT BE USED WITHOUT WRITTEN PERMISSION		