

Features

- **Economical, fifth-generation line interface solution for VoIP processors and SoCs**
- **Smaller, 48-pin 7x7 mm QFN package**
- **Dual Channel Architecture**
- **Single port 4-wire interface control (ZSI)**
 - Compatible with numerous VoIP processors and SoC solutions
 - Less expensive isolation than multi-port control
 - Simplifies board routing
- **VoicePath SDK and VP-API-II Software available to implement FXS functions**
- **VeriVoice Professional Test Suite Software**
 - Comprehensive subscriber loop testing, including *Telcordia GR-909-CORE / TIA-1063* diagnostic testing
 - Industry leading advanced test software
- **VeriVoice Manufacturing Test Package (VVMT)**
 - Facilitates factory testing and calibration of assembled boards
- **Low cost, Energy Efficient Shared Switching Regulator Architecture**
 - Dual Output power supply
 - Integrated battery switches
 - Up to 70 V_{RMS} open circuit ringing with 5 REN load
- **Low cost, 2-Layer PCB Reference Designs**
- **Complete Wideband BORSCHT functionality**
- **Worldwide Programmability**
- **Per channel Narrowband or Wideband operation**

Applications

- **Fixed Wireless (LTE) Gateways**
- **DSL Residential Gateways and Integrated Access Devices (IADs)**
- **Cable Embedded Multimedia Terminal Adapters (eMTAs)**
- **PON Single Family Units (SFU)**
- **Fiber-to-the-premise (FTTX) solutions**

Document ID# 150403

Version 1

September 2014

Ordering Information

Device OPN	Device Type	Package	Packing
Le9642PQCT	SLIC, BBABS	48-pin QFN	Tape & Reel
Le9642PQC	SLIC, BBABS	48-pin QFN	Tray

This Green package meets RoHS 2 Directive 2011/65/EU of the European Council to minimize the environmental impact of electrical equipment.

Description

The miSLIC™ Line Circuits together with a VoIP processor or SoC, provides an economical turn-key solution for derived voice applications. The miSLIC devices are controlled by a VoIP processor or SoC through a simple, single serial interface.

The dual channel Le9642 miSLIC device uses an energy efficient shared power supply topology for reduced BOM cost. The Le9642 can be configured for patent-pending shared Buck-Boost Automatic Battery Switching (BBABS) operation. Ringing and system power management are supported to limit the peak power requirements of each telephone line FXS port. The dual channel Le9642 features wideband clarity and complete BORSCHT functionality.

Manufacturing self test and subscriber line diagnostics are available features. All AC, DC, and power parameters are programmable making the Le9642 device suitable for any short loop application requiring SLIC functionality.

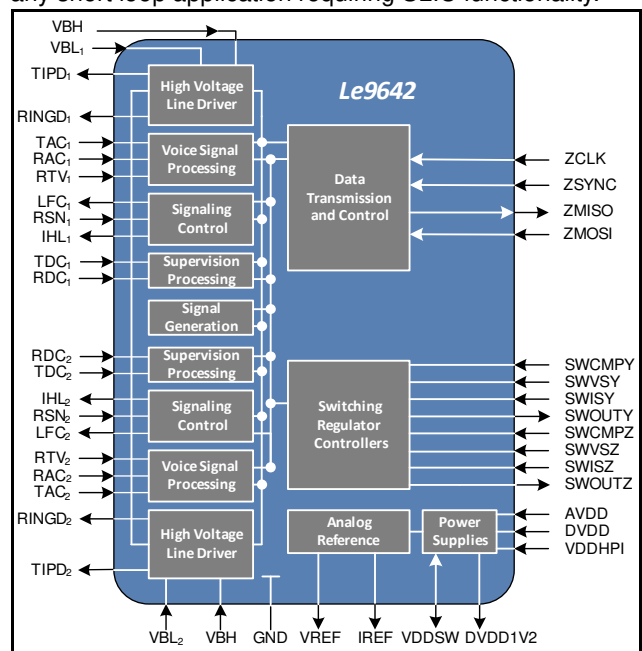

Figure 1 - Le9642 Block Diagram

Selected Electrical Specifications

Description	Symbol	Test Conditions	Min	Typ	Max	Unit
Ambient Temperature, under Bias	T _A		-40		+85	°C
Digital and Analog Supply Voltages	DVDD, AVDD		3.135	3.3	3.465	V _{DC}
Operating Limits:	VBH VBL		$VBH = -(V_{SWITCHER} + (2 * VBL) - 2V)$ $VBL = -40 V_{DC} \text{ to } -25 V_{DC}$			V _{DC}
Line Current:	ILA		18	25	30	mA
Ringing Voltage	V _{RING}	5 REN		50	60	V _{RMS}
Two-Wire Return Loss	R _L	200 to 3400 Hz		30		dB
Longitudinal Balance		1 kHz		58		dB
Device Power Dissipation, Continuous	P _{D(max)}	T _A = 85°C		1.5		W
Junction to Ambient Thermal Resistance	θ _{JA}			29		°C/W

Device Power Consumption (BBABS)	Symbol	Test Conditions	Power	Typ	Unit
Shutdown	P _D	Switcher off	Per Channel	5	mW
Disconnect				25	
Low Power Idle Mode (LPIM)		On-Hook		47	
Idle		On-Hook		99	
Active		Off-Hook, 300 Ω, ILA = 25 mA		520	
Ringing		50 V _{RMS} , 5 REN, other channel in LPIM mode		Both Channels	

Device Pinout

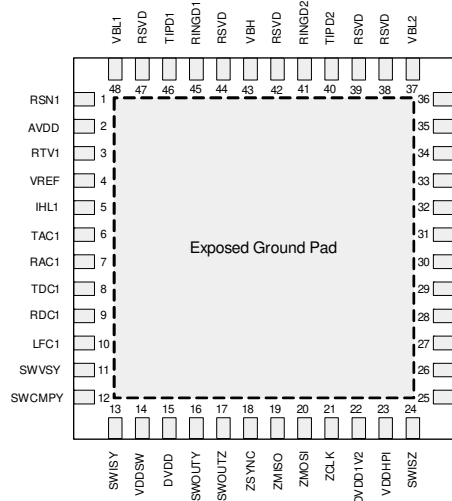

Package Drawings

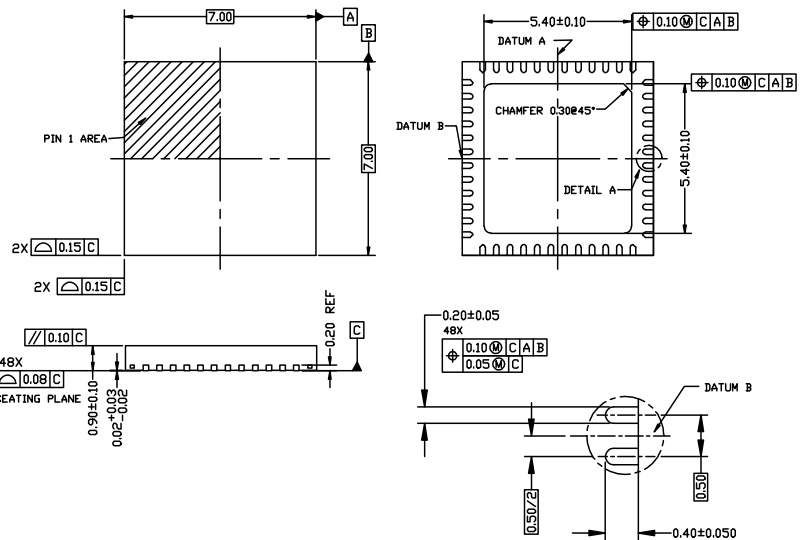

Related Collateral

www.microsemi.com/voice-line-circuits

- *Le9641 Tracking Battery miSLIC™ Line Circuit Preliminary Data Sheet*, Document ID# 148556
 - *ZLR964122L SM2 Line Module, ZSI, 1 FXS, Buck-Boost ABS, 85-V_{PK}, 5 REN*
 - *ZLR964124L SM2 Line Module, PCM/SPI, 1 FXS Buck-Boost and 1 FXS Inverting-Boost, 85-V_{PK}, 5 REN*
- *Le9642 Shared Battery Dual miSLIC™ Line Circuit Preliminary Data Sheet*, Document ID# 148557
 - *ZLR964222L SM2 Line Module, ZSI, 2 FXS, Buck-Boost ABS, 85-V_{PK}, 5 REN*