

REVISIONS

P	LTR	DESCRIPTION	DATE	DWN	APVD
	B2	ECR-23-175652	17MAY23	LZ	EW

- 1 CONTINUOUS STRIP ON REELS
- 2 WIRE RANGE: 500 TO 2200 CMA
- 3 CRIMP WIDTH: .110 F TYPE  
CRIMP HEIGHT:  $(\pm.002)=(\text{TOTAL CMA}+8500)/126000$

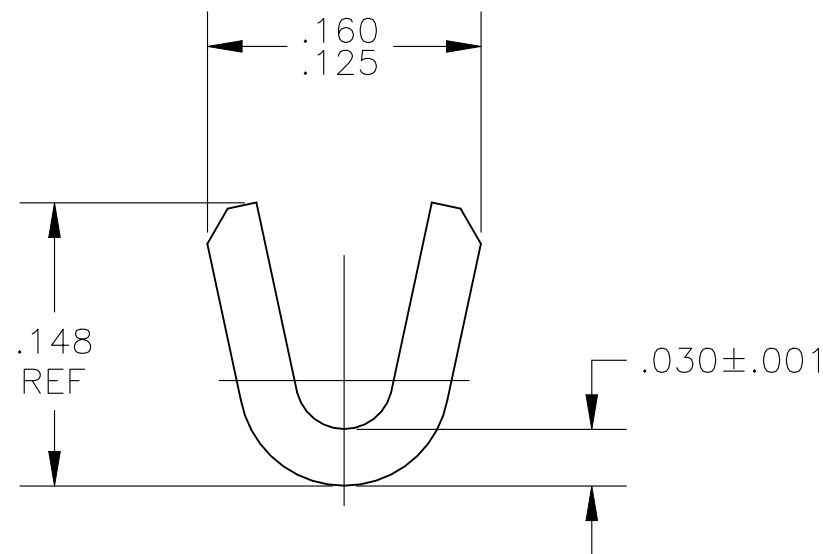
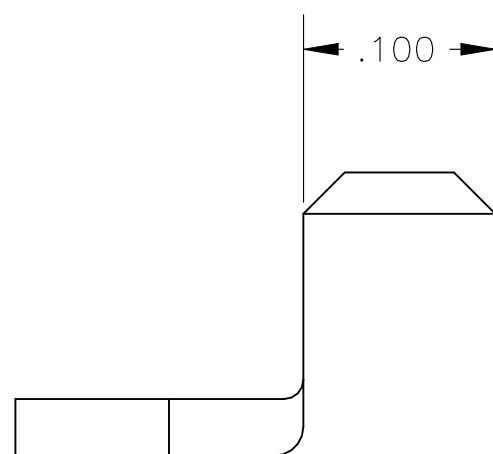
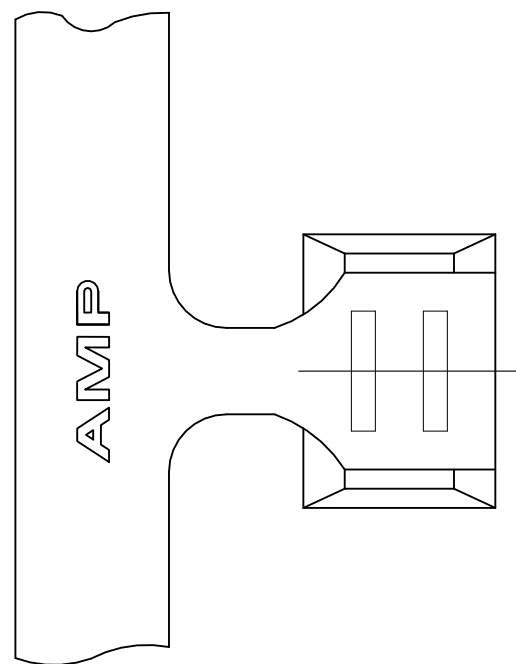

485016-1  
PART NO

THIS DRAWING IS A CONTROLLED DOCUMENT.		DWN RAGHAVENDRA 03JUL07	<b>STE</b> TE Connectivity															
		CHK G.D.PORTA 03JUL07																
DIMENSIONS: INCHES		APVD G.D.PORTA 03JUL07	NAME															
TOLERANCES UNLESS OTHERWISE SPECIFIED:		PRODUCT SPEC	SPLICE															
<table border="0"> <tr><td>0 PLC</td><td>± -</td></tr> <tr><td>1 PLC</td><td>± -</td></tr> <tr><td>2 PLC</td><td>± -</td></tr> <tr><td>3 PLC</td><td>± .010</td></tr> <tr><td>4 PLC</td><td>± -</td></tr> <tr><td>ANGLES</td><td>± -</td></tr> </table>		0 PLC	± -	1 PLC	± -	2 PLC	± -	3 PLC	± .010	4 PLC	± -	ANGLES	± -	APPLICATION SPEC	SIZE	CAGE CODE	DRAWING NO	RESTRICTED TO
0 PLC	± -																	
1 PLC	± -																	
2 PLC	± -																	
3 PLC	± .010																	
4 PLC	± -																	
ANGLES	± -																	
MATERIAL BRASS	FINISH NONE	WEIGHT -	A3	00779	C-485016	-												
CUSTOMER DRAWING			SCALE	SHEET	REV													
			10:1	1 OF 1	B2													