

ABSTRACT

This user's guide describes the characteristics, operation, and use of the TMP114EVM evaluation board. This user's guide discusses the hardware, how to set up and configure the software, and reviews various aspects of the software operation. Throughout this document, the terms evaluation board, evaluation module, and EVM are synonymous with the TMP114EVM. This user's guide also provides information on the operating procedure, input and output connections, an electrical schematic, printed circuit board (PCB) layout drawings, and a parts list for the EVM.

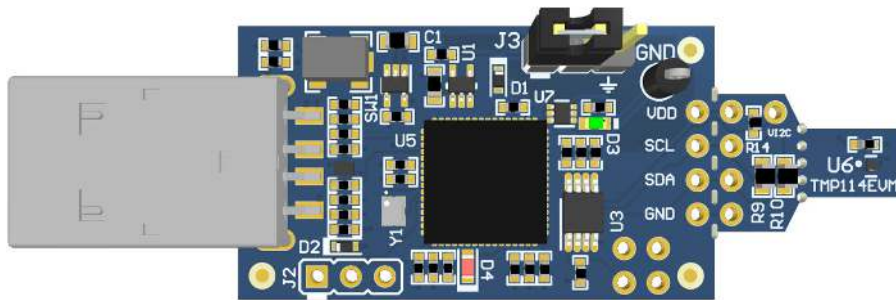

Table of Contents

1 Trademarks	2
2 Overview	2
2.1 EVM Kit Contents.....	2
3 EVM Hardware	3
3.1 TMP114EVM Board.....	3
3.2 Perforations.....	3
3.3 Subregulator.....	3
3.4 Logic Level Translator.....	3
3.5 Status LEDs.....	3
3.6 Programming Header.....	4
3.7 BSL Button.....	4
3.8 EVM Operating Conditions.....	4
4 Software Download	5
4.1 Live Software on dev.ti.com.....	5
4.2 Offline Software.....	5
5 Software	6
5.1 Home Tab.....	6
5.2 Data Capture Tab.....	7
5.3 Settings Tab.....	8
5.4 Registers Tab.....	9
5.5 Collateral Tab.....	10
6 Schematic, Board Layout and Bill of Materials	11
6.1 Schematic.....	11
6.2 Printed Circuit Board (PCB).....	11
6.3 Bill of Materials.....	12
7 Revision History	15

1 Trademarks

All trademarks are the property of their respective owners.

2 Overview

The TMP114EVM allows users to evaluate the performance of the TMP114 digital temperature sensor. The EVM comes in a USB stick form factor, with an onboard MSP430F5528 microcontroller that interfaces with both the host computer and the TMP114 device using an I²C interface. The module is designed with perforations between the sensor and host controller on the EVM board. The perforation allows the user flexibility in their evaluation:

- The user can connect the TMP114 to the user's system/host.
- The user can connect the EVM host and software to the user's system with TMP114 devices.
- Small individual boards allow the user to place sensors in the user's system.
- Hole spacing is compatible with common 0.1" prototyping breadboards.

2.1 EVM Kit Contents

Table 2-1 details the contents of the EVM kit. Contact the Texas Instruments Product Information Center nearest you if any components are missing. TI highly recommends that users check the TI website at <https://www.ti.com> to verify that they have the latest versions of the related software.

Table 2-1. EVM Kit Contents

Item	Quantity
TMP114EVM	1

CAUTION

The TMP114 integrated circuit and other components on the TMP114EVM can be damaged by electrostatic discharge (ESD). Texas Instruments recommends that all integrated circuits be handled with appropriate precautions. Failure to observe proper handling and installation procedures can cause damage. ESD damage can range from subtle performance degradation to complete device failure.



3 EVM Hardware

3.1 TMP114EVM Board

TMP114EVM shows an image of the TMP114EVM with some of the hardware features of the design labeled.

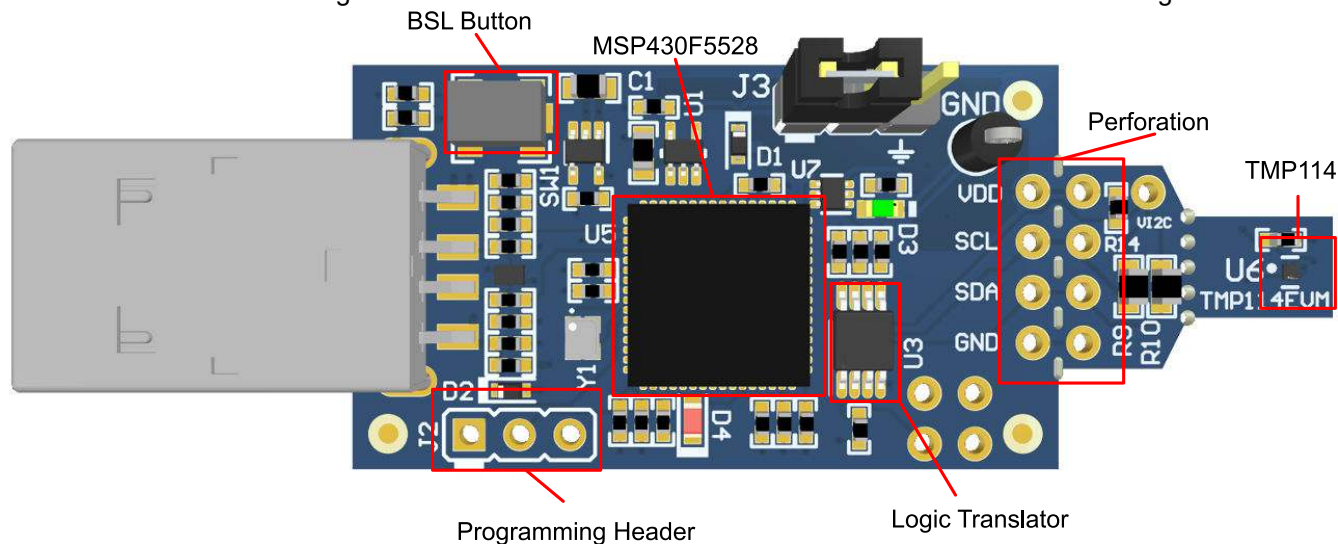

Figure 3-1. TMP114EVM

3.2 Perforations

The perforation between the USB controller board and TMP114 sensor board includes a footprint for a standard 100-mil, 4-in header on each side. These pins are labeled with their functions on the board silkscreen, and can be used for either debug, or to provide electrical connection when the TMP114 and controller board need to be separated for testing.

3.3 Subregulator

Pins 1 and 2 of the 100-mil header J3 can be shorted with a jumper to supply 1.2-V power to the TMP114 from the onboard LDO (U1). Alternatively, the jumper between pins 1 and 2 can be removed, and pins 2 and 3 of J3 can be used to supply power to the onboard TMP114. The onboard level shifter will perform any necessary translation of the I²C lines between the external power source and the TMP114EVM controller. When power is supplied to the TMP114 using either method, the green LED D3 will illuminate.

3.4 Logic Level Translator

The translator U3 separates the MSP430 I²C host from the TMP114 device. This is not required for end applications, but the translator is provided on the EVM as a courtesy. When the subregulator is disabled, a voltage between 1.2 V and 1.8 V can be applied at the VDD net, which is the VDD pin on the perforation, or pin 2 of the header J3. This external voltage will illuminate the green LED D3 and power the TMP114 device.

3.5 Status LEDs

The TMP114EVM includes two LEDs, D3 and D4, which indicate the status of the board at any time. The green LED D3, illuminates when power is supplied to the VDD net. The VDD net is connected directly to pin A1 of the TMP114, and externally supplied power should not exceed 1.98 V.

The red LED D4, is a status LED for the MSP430F5528. Table 3-1 summarizes the functions of D4.

Table 3-1. D4 LED Statuses

D4 LED STATUS	MEANING
Off	USB2ANY controller is unpowered, or still initializing
Blinking	USB2ANY controller is powered, but not connected
On	USB2ANY controller is connected

3.6 Programming Header

The TMP114EVM comes pre-loaded with firmware that is necessary for the correct operation of the USB interface and PC GUI software. The unpopulated header, J2, is provided for Spy-Bi-Wire access to the MSP430F5528. TI does not recommend that users access this header or reprogram the device. However this header may be required for recovery if firmware corruption of the TMP114EVM occurs at any point.

3.7 BSL Button

The TMP114EVM features push-button SW1 for entering USB BSL mode. This can be used for any necessary firmware updates. This method is preferred over the use of the Spy-Bi-Wire programming header for firmware loading.

3.8 EVM Operating Conditions

The TMP114EVM power is supplied through the USB connector. The LDO (U1) converts the 5 V from the USB to 3.3 V used by the TMP114 and the MSP430. The EVM may be directly inserted into a USB port on a PC or laptop, or may be connected to the latter using an appropriate USB cable.

The controller and device sides of the EVM have different temperature limits as shown in [Table 3-2](#). These are set by the onboard MSP430F5528 and the TMP114 ICs on the controller and breakout portions respectively.

Table 3-2. TMP114EVM Temperature Limits

BOARD SECTION	CONDITIONS	TEMPERATURE RANGE
Controller Board	Recommended operating free-air temperature, T_A	-40 °C to 125 °C
	Absolute maximum junction temperature, T_J	95 °C
TMP114 Breakout	Recommended operating free-air temperature, T_A	-40 °C to 125 °C
	Absolute maximum junction temperature, T_J	-55 °C to 150 °C

4 Software Download

The PC GUI Software for TMP114EVM runs on TI's GUI Composer framework. The software is available as a live version which runs in your browser, and it is available as a download for offline use. The software is compatible with Windows, Mac, and Linux operating systems.

4.1 Live Software on dev.ti.com

The live software currently works on Chrome, Firefox, and Safari browsers. Internet Explorer is not supported. Users can access the live version through one of the following actions:

- Go to the EVM tool page and click on the View button
- Go to dev.ti.com/gallery, login with your myTI account credentials, and search for TMP114, or go [here](#) and select the TMP114 GUI from the gallery.

Click the application icon within the gallery to launch the software. Click the prompt to install the TI Cloud Agent Bridge browser plugin.

4.2 Offline Software

4.2.1 Download from dev.ti.com

Users can access the latest version of the offline software by navigating to the live version as noted above. Look for the download icon  and download both the application and runtime for the operating system as shown in [Figure 4-1](#).

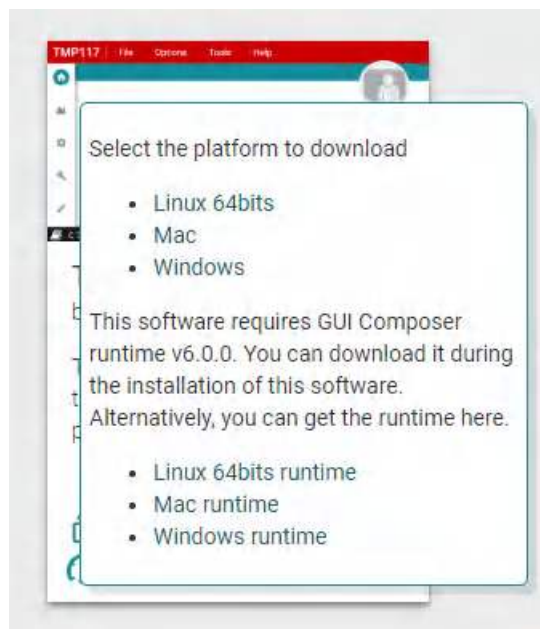

Figure 4-1. Download Pop-Up

5 Software

5.1 Home Tab

The Home Tab is shown at software launch. The "Learn More..." link displays the features of and the functional diagram for the TMP114 device. The icons on the bottom of this tab are shortcuts to the other functional tabs of the GUI, and correspond to the icons on the left-hand-side of the GUI.

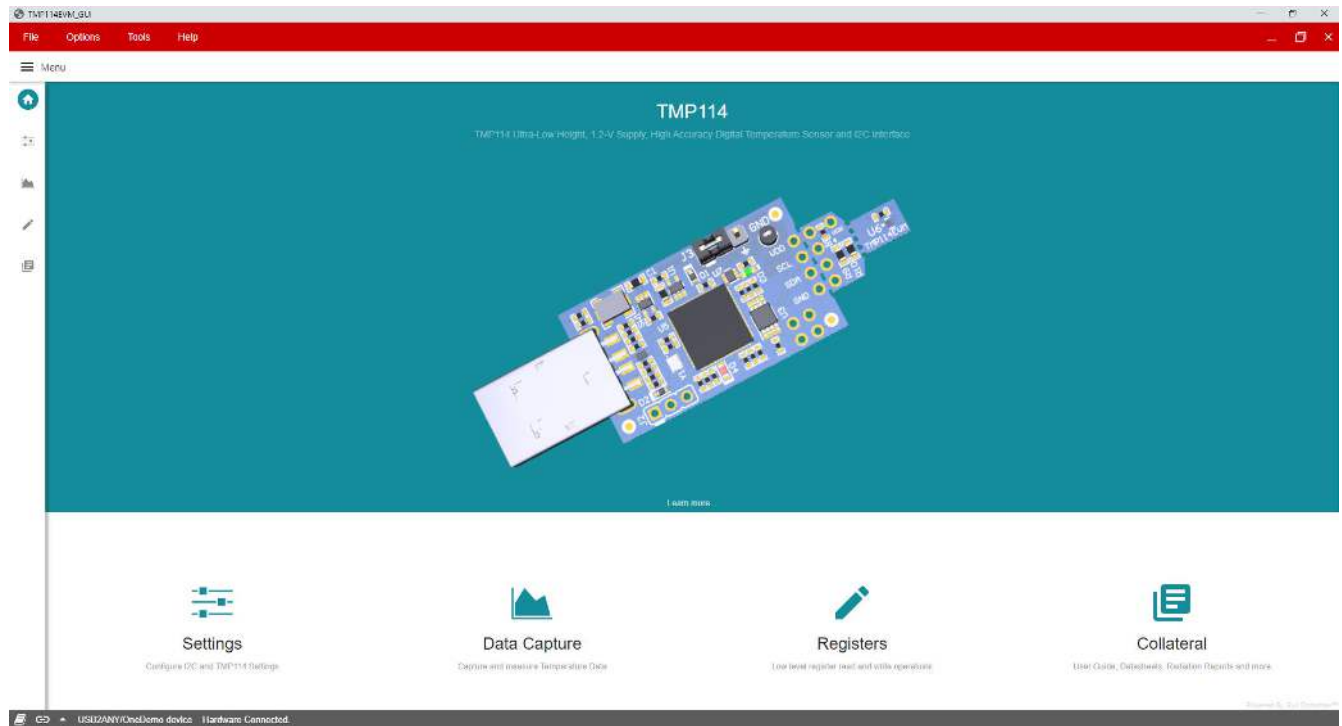

Figure 5-1. Home

5.2 Data Capture Tab

The Data Capture tab reports the temperature from the TMP114 device included on the TMP114EVM. To enable Data Capture, select a refresh rate setting at the bottom of the tab. The raw temperature data and slew rate measurements are shown by default. The user can click the raw temperature data and slew rate measurements entries in the legend on the right-hand-side of the graph to disable their display on the screen.

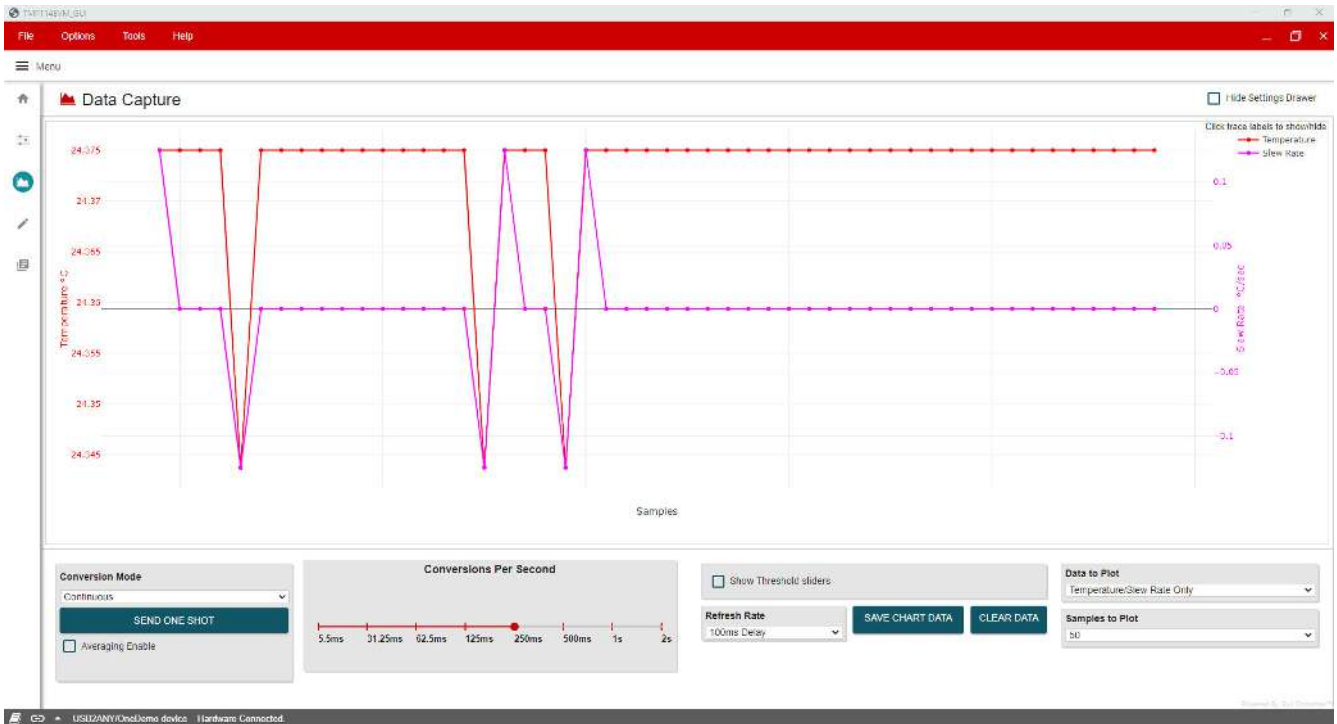

Figure 5-2. Data Capture

5.3 Settings Tab

The Settings tab provides the hardware configuration for the USB to I²C bridge and device features for the TMP114 device.

Selecting the wrong Device I²C Address will cause the GUI to disconnect from the USB device. To use the EVM with a different address, a swap out of the TMP114 device is required. The link icon in the bottom-left corner indicates the current connection status, and the user can click the area to change the connection status.

The other widgets within the Settings tab may be used to easily configure the settings of the TMP114. How these changes are written on the I²C bus will depend on the settings in the Registers tab. For example, if the user makes changes to the High and Low Limit sliders, this will trigger an immediate write to the TMP114's limit registers only if Immediate mode is enabled on the Registers tab.

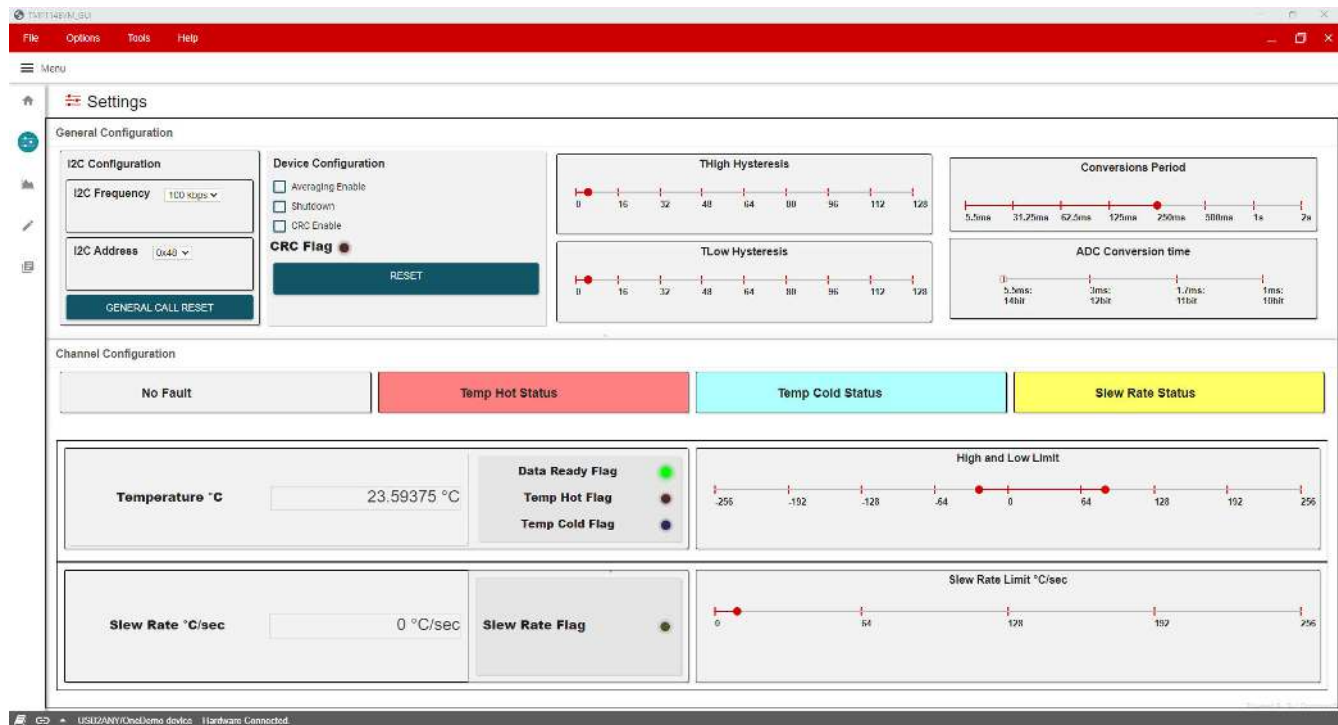

Figure 5-3. Settings

5.4 Registers Tab

The Registers tab interacts with the registers and bits within the TMP114 device.

The Auto Read drop-down box configures polling of register contents. When Auto Read is Off, it is necessary to click Read Register to fetch the contents of the current register. Read All Registers can be used to fetch the contents of all registers at once. The Write Register button is greyed and disabled when the drop-down next to the button is set to Immediate. Immediate mode triggers a Write operation each time a register is modified. When Deferred mode is selected, the Write Register button is enabled, and write operations will not be performed unless the Write Register button is clicked. These settings give the user total control over I²C Bus activity, and enable individual transactions to be easily observed with an oscilloscope, logic analyzer, or bus-sniffing device.

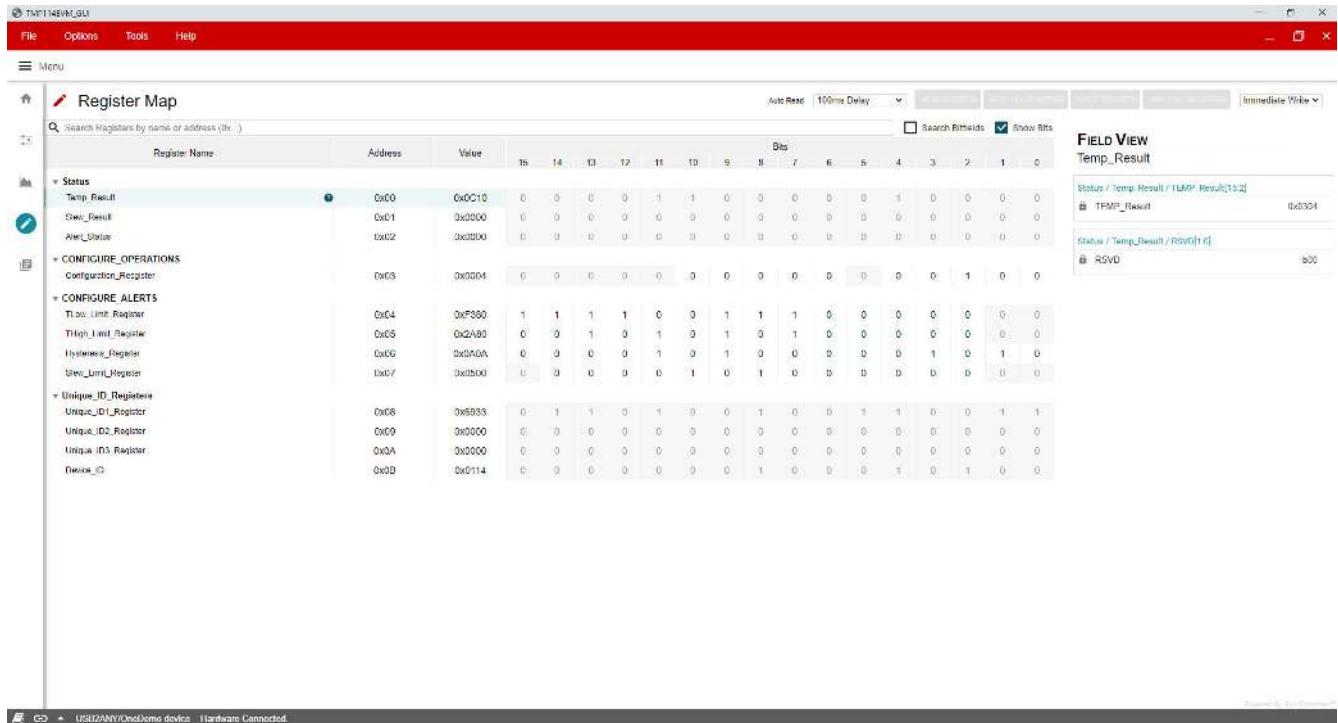

Figure 5-4. Registers

5.5 Collateral Tab

The Collateral tab contains links to the EVM user's guide, the tool page on ti.com, as well as links to the product data sheet and other relevant links.

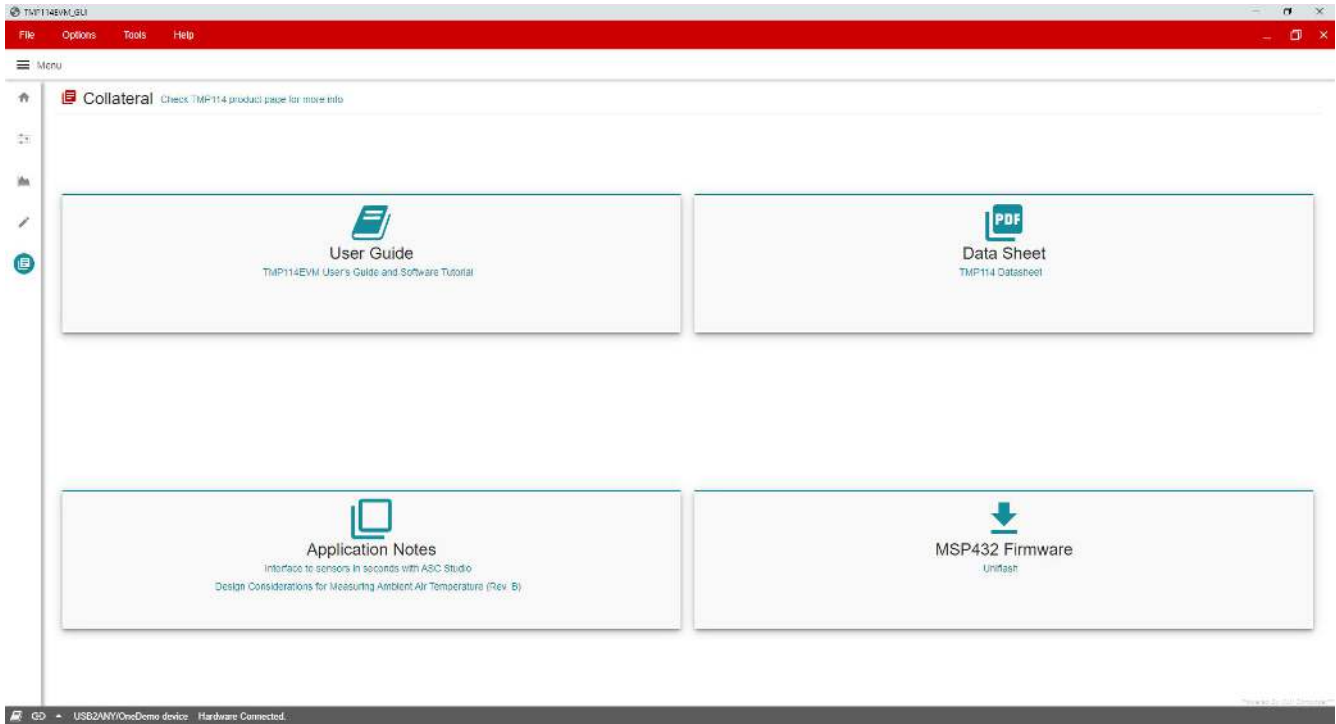

Figure 5-5. Collateral

6 Schematic, Board Layout and Bill of Materials

6.1 Schematic

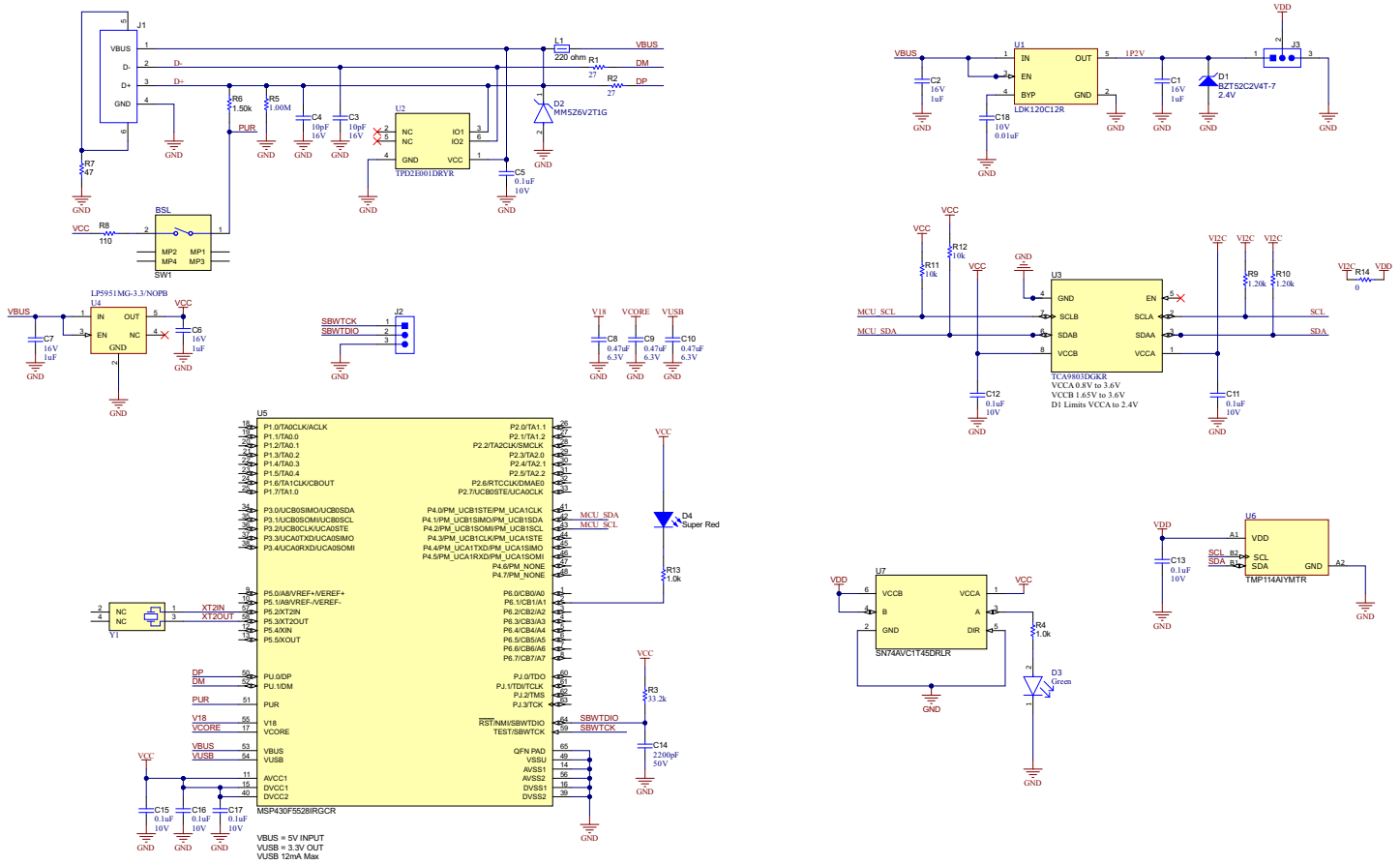

Figure 6-1. Schematic

6.2 Printed Circuit Board (PCB)

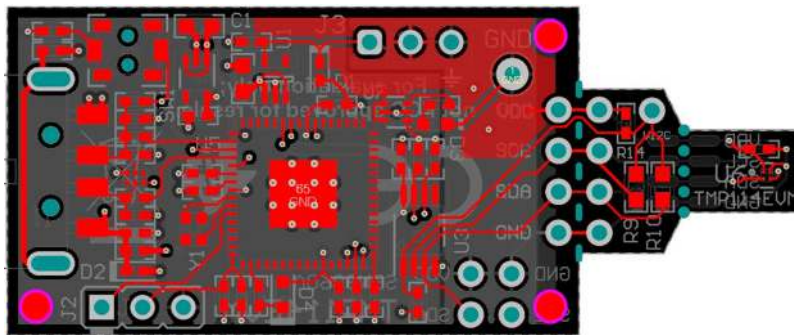
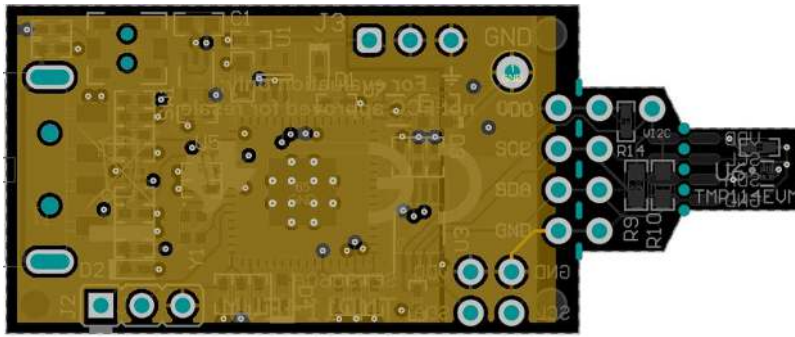
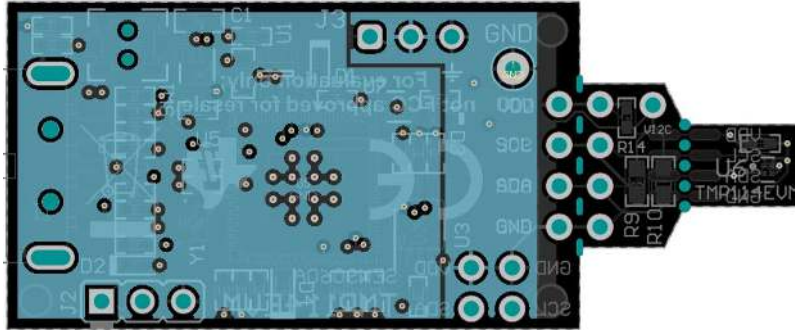
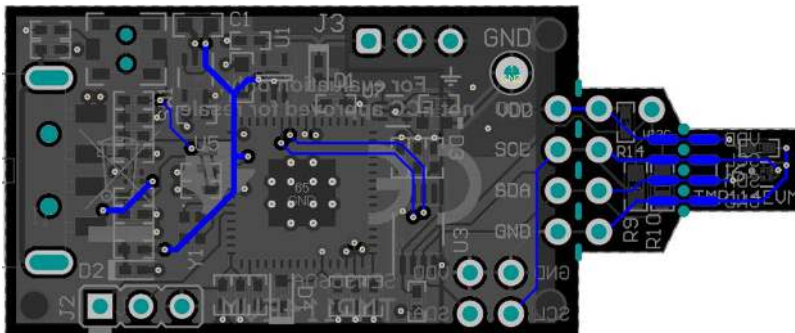

Figure 6-2. Top View

Figure 6-3. Layer 1 (Ground Plane)

Figure 6-4. Layer 2 (Power Plane)

Figure 6-5. Bottom View

6.3 Bill of Materials

Table 6-1. Bill of Materials

Designator	Quantity	Value	Description	Package Reference	PartNumber	Manufacturer
!PCB1	1		Printed Circuit Board		SENS060	Any
C1, C2, C6, C7	4	1uF	CAP, CERM, 1 uF, 16 V, +/- 10%, X5R, 0402	0402	EMK105BJ105KVHF	Taiyo Yuden
C3, C4	2	10pF	CAP, CERM, 10 pF, 16 V,+/- 10%, C0G, 0402	0402	C0402C100K4GACTU	Kemet
C5, C11, C12, C13, C15, C16, C17	7	0.1uF	CAP, CERM, 0.1 uF, 10 V,+/- 10%, X5R, 0402	0402	LMK105BJ104KV-F	Taiyo Yuden

Table 6-1. Bill of Materials (continued)

Designator	Quantity	Value	Description	Package Reference	PartNumber	Manufacturer
C8, C9, C10	3	0.47uF	CAP, CERM, 0.47 uF, 6.3 V, +/- 10%, X7R, 0402	0402	JMK105B7474KV HF	Taiyo Yuden
C14	1	2200pF	CAP, CERM, 2200 pF, 50 V, +/- 5%, X7R, 0402	0402	CL05B222JB5NN NC	Samsung Electro-Mechanics
C18	1	0.01uF	CAP, CERM, 0.01 uF, 10 V, +/- 10%, X5R, 0402	0402	GRM155R61A103 KA01D	MuRata
D1	1	2.4V	Diode, Zener, 2.4 V, 300 mW, SOD-523	SOD-523	BZT52C2V4T-7	Diodes Inc.
D2	1	6.2V	Diode, Zener, 6.2 V, 500 mW, SOD-523	SOD-523	MM5Z6V2T1G	On Semiconductor
D3	1	Green	LED GREEN DIFFUSED CHIP SMD	LED, GREEN, 0603	HSMG-C191	Broadcom
D4	1	Super Red	LED, Super Red, SMD	LED_0603	150060SS75000	Würth Elektronik
J1	1		Connector, Plug, USB Type A, R/A, Top Mount SMT	USB Type A right angle	48037-1000	Molex
J3	1		Header, 2.54 mm, 3x1, Tin, TH	Header, 2.54 mm, 3x1, TH	TSW-103-07-T-S	Samtec
L1	1	220 ohm	Ferrite Bead, 220 ohm @ 100 MHz, 0.45 A, 0402	0402	BLM15AG221SN1 D	MuRata
R1, R2	2	27	RES, 27, 5%, 0.063 W, AEC-Q200 Grade 0, 0402	0402	CRCW040227R0J NED	Vishay-Dale
R3	1	33.2k	RES, 33.2 k, 1%, 0.063 W, AEC-Q200 Grade 0, 0402	0402	CRCW040233K2F KED	Vishay-Dale
R4, R13	2	1.0k	RES, 1.0 k, 5%, 0.1 W, AEC-Q200 Grade 0, 0402	0402	ERJ-2GEJ102X	Panasonic
R5	1	1.00Meg	RES, 1.00 M, 1%, 0.063 W, 0402	0402	RC0402FR-071M L	Yageo America
R6	1	1.50k	RES, 1.50 k, 1%, 0.063 W, AEC-Q200 Grade 0, 0402	0402	RMCF0402FT1K5 0	Stackpole Electronics Inc

Table 6-1. Bill of Materials (continued)

Designator	Quantity	Value	Description	Package Reference	PartNumber	Manufacturer
R7	1	47	RES, 47, 5%, 0.1 W, AEC-Q200 Grade 0, 0402	0402	ERJ-2GEJ470X	Panasonic
R8	1	110	RES, 110, 1%, 0.1 W, AEC-Q200 Grade 0, 0402	0402	ERJ-2RKF1100X	Panasonic
R9, R10	2	10k	RES, 10 k, 5%, 0.1 W, 0603	0603	RC0603JR-0710K L	Yageo
R14	1	0	RES, 0, 5%, 0.063 W, AEC-Q200 Grade 0, 0402	0402	RK73Z1ETTP	KOA Speer
SH-J1	1		Shunt, 2.54mm, Gold, Black	Shunt, 2.54mm, Black	60900213421	Wurth Elektronik
SW1	1		Switch, SPST-NO, Off-Mom, 0.05A, 12VDC, SMD	3.9x2.9mm	PTS820 J20M SMTR LFS	C&K Components
U1	1		Linear Voltage Regulator IC Positive Fixed 1 Output 200mA SOT-323-5	SOT-323-5	LDK120C12R	STMicroelectronic s
U2	1		4-Channel ESD Protection Array for High-Speed Data Interfaces, DRY0006A (USON-6)	DRY0006A	TPD4E004DRYR	Texas Instruments
U3	1		Level-Shifting I2C Bus Repeater, DGK0008A (VSSOP-8)	DGK0008A	TCA9803DGKT	Texas Instruments
U4	1		Micropower, 150mA Low- Dropout CMOS Voltage Regulator, 5-pin SC-70, Pb- Free	DCK0005A	LP5951MG-3.3/ NOPB	Texas Instruments
U5	1		16-Bit Ultra- Low-Power Microcontroller, 128KB Flash, 8KB RAM, USB, 12Bit ADC, 2 USCs, 32Bit HW MPY, RGC0064B (VQFN-64)	RGC0064B	MSP430F5528IR GCR	Texas Instruments

Table 6-1. Bill of Materials (continued)

Designator	Quantity	Value	Description	Package Reference	PartNumber	Manufacturer
U6	1		Ultra-Low Height, 1.2-V Supply, High Accuracy Digital Temperature Sensor and I ² C Interface	PicoStar4	TMP114AIYMTR	Texas Instruments
U7	1		Single-Bit Dual-Supply Bus Transceiver with Configurable Voltage Translation and 3-State Outputs, DRL0006A, LARGE T&R	DRL0006A	SN74AVC1T45DR LR	Texas Instruments
Y1	1		Crystal, 24 MHz, SMD	2x1.6mm	XRCGB24M000F2 P00R0	MuRata
J2	0		Header, 2.54 mm, 3x1, Gold, TH	Header, 2.54 mm, 3x1, TH	GBC03SAAN	Sullins Connector Solutions

7 Revision History

NOTE: Page numbers for previous revisions may differ from page numbers in the current version.

Changes from Revision A (September 2021) to Revision B (July 2022)	Page
• Added caution note to <i>EVM Kit Contents</i> section.....	2
• Added CE marking to the document.....	2

Changes from Revision * (May 2021) to Revision A (September 2021)	Page
• Changed the <i>Schematic</i> image.....	11
• Changed the <i>Bill of Materials</i> table.....	12

IMPORTANT NOTICE AND DISCLAIMER

TI PROVIDES TECHNICAL AND RELIABILITY DATA (INCLUDING DATA SHEETS), DESIGN RESOURCES (INCLUDING REFERENCE DESIGNS), APPLICATION OR OTHER DESIGN ADVICE, WEB TOOLS, SAFETY INFORMATION, AND OTHER RESOURCES "AS IS" AND WITH ALL FAULTS, AND DISCLAIMS ALL WARRANTIES, EXPRESS AND IMPLIED, INCLUDING WITHOUT LIMITATION ANY IMPLIED WARRANTIES OF MERCHANTABILITY, FITNESS FOR A PARTICULAR PURPOSE OR NON-INFRINGEMENT OF THIRD PARTY INTELLECTUAL PROPERTY RIGHTS.

These resources are intended for skilled developers designing with TI products. You are solely responsible for (1) selecting the appropriate TI products for your application, (2) designing, validating and testing your application, and (3) ensuring your application meets applicable standards, and any other safety, security, regulatory or other requirements.

These resources are subject to change without notice. TI grants you permission to use these resources only for development of an application that uses the TI products described in the resource. Other reproduction and display of these resources is prohibited. No license is granted to any other TI intellectual property right or to any third party intellectual property right. TI disclaims responsibility for, and you will fully indemnify TI and its representatives against, any claims, damages, costs, losses, and liabilities arising out of your use of these resources.

TI's products are provided subject to [TI's Terms of Sale](#) or other applicable terms available either on ti.com or provided in conjunction with such TI products. TI's provision of these resources does not expand or otherwise alter TI's applicable warranties or warranty disclaimers for TI products.

TI objects to and rejects any additional or different terms you may have proposed.

Mailing Address: Texas Instruments, Post Office Box 655303, Dallas, Texas 75265
Copyright © 2022, Texas Instruments Incorporated