

# 3mm (T1) Package Discrete LED NEUTRAL WHITE



## 3UWCX.XXXN-X

- ◆ Industry Standard 3mm (T1) Package
- ◆ RoHS Compliant
- ◆ Water Clear Lens
- ◆ 5000K Color Temperature
- ◆ Multiple Intensity and Viewing Angle Options
- ◆ Available in Flange and Standard LED Body styles
- ◆ Ideal for Status Indication and Display

Bivar's 3mm T1 Package 3UWC Series LED may be used in almost any application. They are offered in 5000K color temperature and come in multiple intensity, viewing angle, and body styles. Bivar offers a water clear LED lens for maximum light output. The Flange LED is ideal for Panel Mount Clip & Ring assemblies and the Standard LED is ideal for vertical spacer and holder assemblies.

Part Number	Material	Emitted Color	Color Temperature	Lens Appearance	Viewing Angle
3UWC5.035N-F	InGaN/Sapphire	WHITE	5000K	Water Clear	35°
3UWC8.035N-F					35°
3UWC5.030N					30°
3UWC8.030N					30°

## Part Number Designation

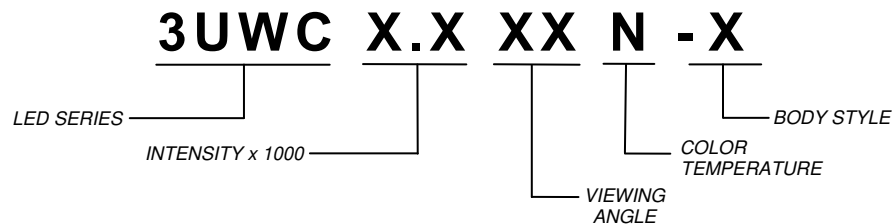

Bivar reserves the right to make changes at any time without notice.

# 3mm (T1) Package Discrete LED NEUTRAL WHITE



## Outline Dimensions

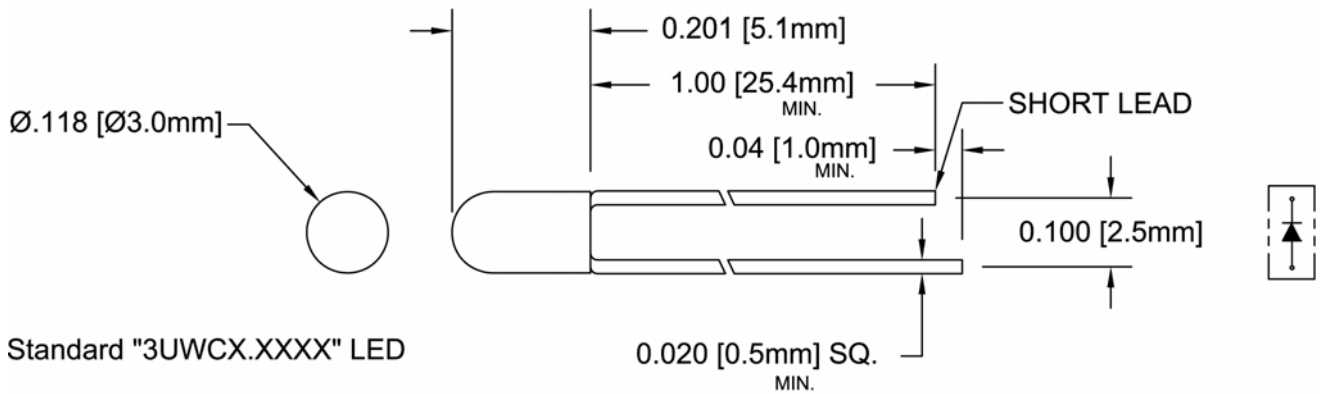
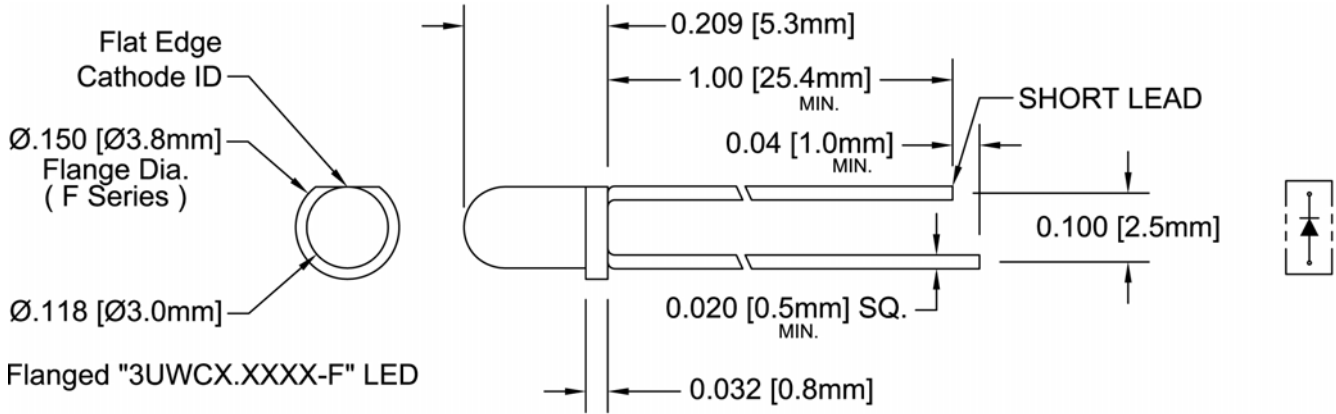

### Recommended Mounting

$$\text{Hole Size} = \text{Ø}.032^{+.003}_{-.002}$$

#### Outline Drawings Notes:

1. All dimensions are in inches [millimeters].
2. Standard tolerance:  $\pm 0.010$ " unless otherwise noted.
3. Tolerance of overall epoxy outline:  $\pm 0.020$ " unless otherwise noted.
4. Epoxy meniscus may extend to 0.060" max.

Bivar reserves the right to make changes at any time without notice.

# 3mm (T1) Package Discrete LED NEUTRAL WHITE



## Absolute Maximum Ratings

T<sub>A</sub> = 25°C unless otherwise noted

Power Dissipation	120 mW
Forward Current ( DC )	30 mA
Peak Forward Current <sup>1</sup>	100 mA
Reverse Voltage	5 V
Operating Temperature Range	-25 ~ +80°C
Storage Temperature Range	-30 ~ +80°C
Lead Soldering Temperature ( 3 mm from the base of the epoxy bulb ) <sup>2</sup>	260°C

Notes: 1. 10% Duty Cycle, Pulse Width ≤ 0.1 msec.      2. Solder time less than 5 seconds at temperature extreme.

## Electrical / Optical Characteristics

T<sub>A</sub> = 25°C & I<sub>F</sub> = 20 mA unless otherwise noted

Part Number	Forward Voltage (V) <sup>1</sup>			Recommend Forward Current (mA)			Reverse Current (μA)	CCT (Kelvin)			Luminous Intensity I <sub>v</sub> (mcd)			Viewing Angle 2θ <sub>1/2</sub> (deg)
	MIN	TYP	MAX	MIN	TYP	MAX	MAX	MIN	TYP	MAX	MIN	TYP	MAX	TYP
3UWC5.035N-F	3.0	3.4	3.8	/	20	/	10	/	5000	/	4000	5000	/	35
3UWC8.035N-F								/	5000	/	6000	8000	/	35
3UWC5.030N	3.0	3.4	3.8	/	20	/	10	/	5000	/	4000	5000	/	30
3UWC8.030N								/	5000	/	6000	8000	/	30

Notes: 1. Tolerance of forward voltage : ±0.05V.

## Directivity Radiation — Relative Luminous Intensity vs. Radiation Angle

T<sub>a</sub> = 25°C unless other noted

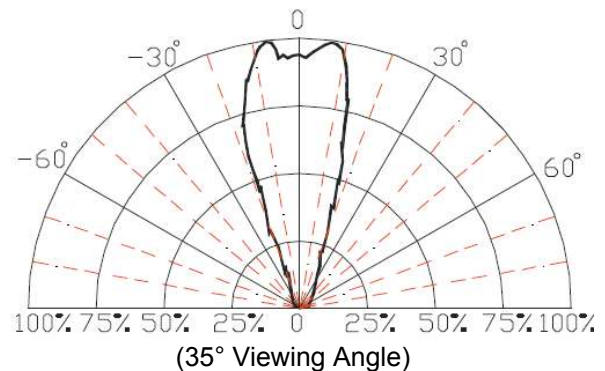
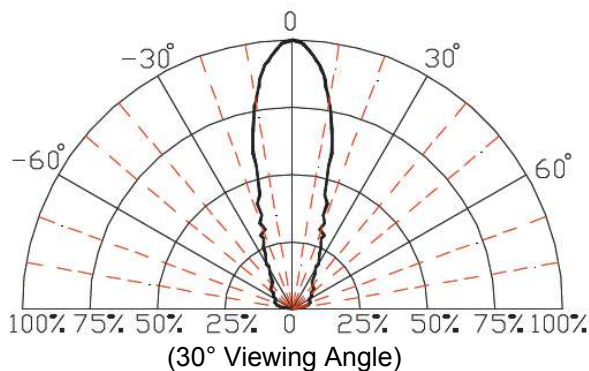

Bivar reserves the right to make changes at any time without notice.

# 3mm (T1) Package Discrete LED NEUTRAL WHITE



## Typical Electrical / Optical Characteristics

$T_A = 25^\circ\text{C}$  unless otherwise noted

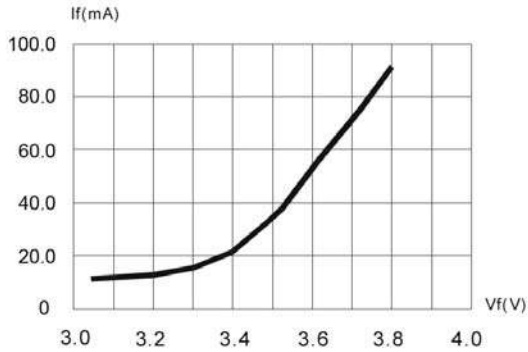

Fig. 1 Forward Current vs. Forward Voltage

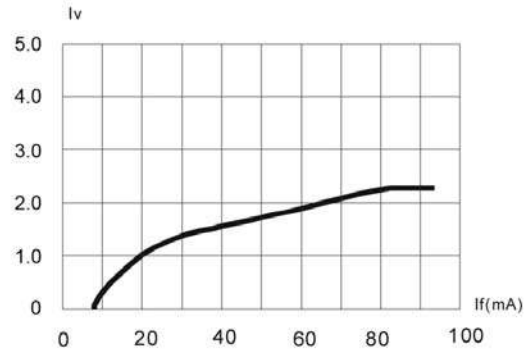

Fig. 2 Relative Luminous Intensity vs. Forward Current

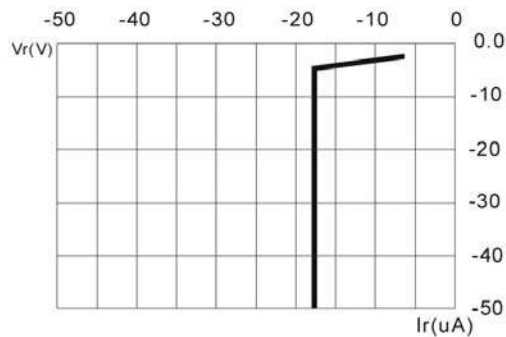

Fig. 3 Reverse Current vs. Reverse Voltage

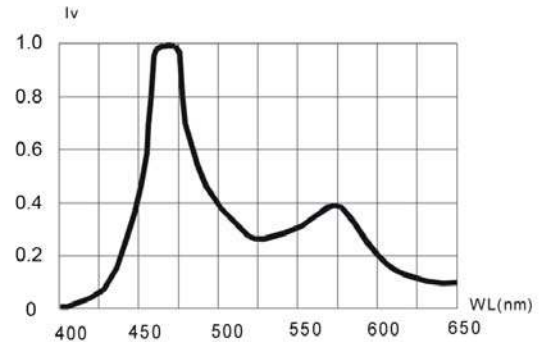

Fig. 4 Relative Luminous Intensity vs. Wavelength

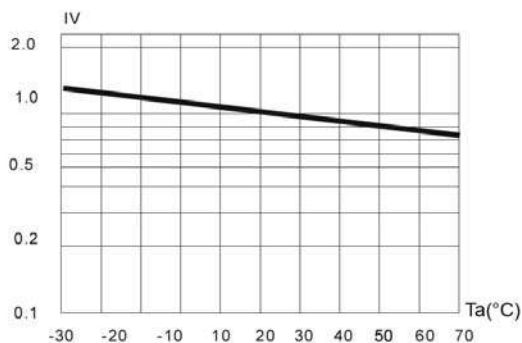

Fig. 5 Relative Luminous Intensity vs. Ambient Temperature

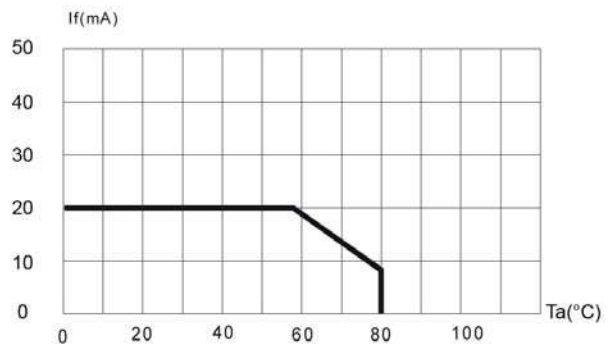

Fig. 6 Maximum Forward Current vs. Ambient Temperature

Bivar reserves the right to make changes at any time without notice.

# 3mm (T1) Package Discrete LED NEUTRAL WHITE



## Recommended Soldering Conditions

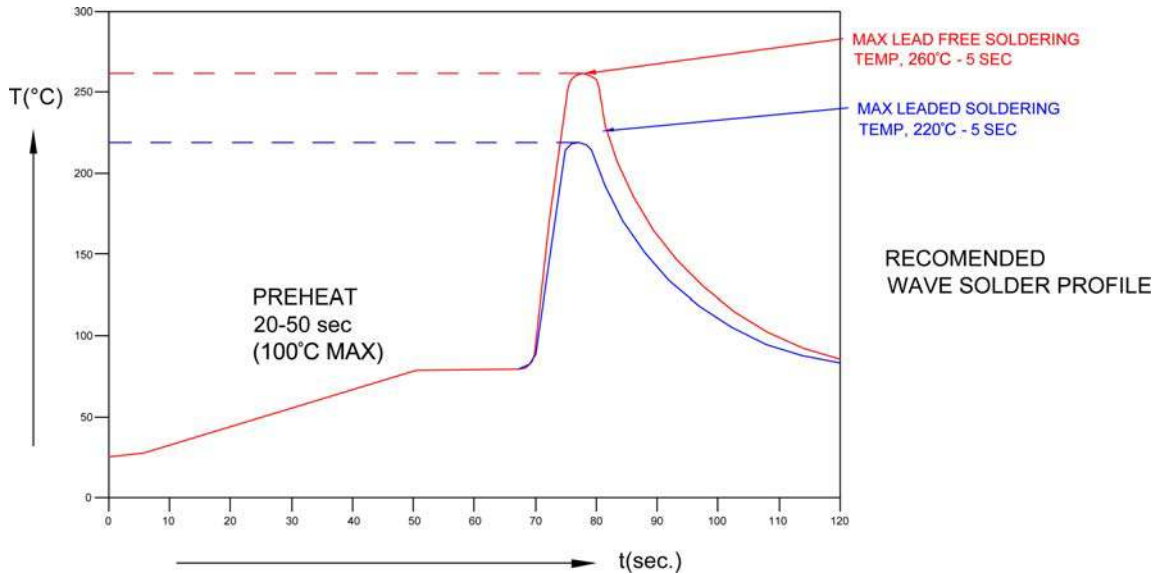

Recommended Lead Free Wave Soldering Profile	
Preheat Temperature: 100°C Max.	Peak Temperature: 260°C Max.
Preheat Time: 20 ~ 50 Seconds	Solder Time Above 217°C: 5 Seconds Max.
Note: Turn off top heater at preheat to prevent the lamp body directly exposed to the heat source.	

## Packaging and Labeling Plan



**Bivar, Inc.** MSL 1

4 Thomas, Irvine, CA 92618-2593  
 LOT: XXX.XXXXXX.XX



Part: **XXXX-XXX-XXX**

Quantity: **.500**

RoHS Compliant

AntiStatic Poly Bag with Desiccant  
(500 pcs Max. per Bag)

Bivar reserves the right to make changes at any time without notice.