

Description

The AP9211 is a single chip protection solution specially designed for 1-cell Li+ rechargeable battery pack application.

The AP9211 includes a 1-cell lithium-ion battery protection chip and dual n-channel MOSFET with common drain.

The AP9211 provides rich battery protection features and can turn off the n-channel MOSFET by detecting overcharge voltage/current, overdischarge voltage/current, or load short circuit. The AP9211 has built-in fixed delay time to save external components.

The AP9211 is available in U-DFN2030-6 (Type C) package.

Features

- High Voltage CMOS Process, up to 30V (VDD to VM)
- Low Quiescent Current (+25°C)
- In Normal Mode, 3.0μA (typ), 4.5μA (max) V_{DD} = 3.5V
- In Power-Down Mode, 0.1μA (max)
- High-Accuracy Voltage Detection Circuit (+25°C)
- Overcharge Detection Voltage: 3.5V to 4.5V (5mV Steps)
Accuracy ±25mV
- Overcharge Hysteresis Voltage Range: 0.1V to 0.4V (50mV Steps) Accuracy ±50mV
- Overdischarge Detection Voltage: 2.0V to 3.4V (10mV Steps)
Accuracy ±35mV
- Overdischarge Hysteresis Voltage Range: 0V to 0.7V (40mV Steps) Accuracy ±65mV
- Discharge Overcurrent Detection Voltage: 0.05V to 0.32V (10mV Steps) Accuracy ±15mV
- Short Current Detection Voltage: 0.45V to 0.7V (50mV Steps)
Accuracy ±100mV
- Charge Overcurrent Detection Voltage: -0.2V to -0.05V (10mV Steps) Accuracy ±15mV
- Overcharge Detection Voltage: 8.0V (Fixed) Accuracy ±2V
- Overcharge Release Voltage: 7.3V (Fixed) Accuracy ±2V
- Built-in Fixed Detection Delay Time (+25°C), Accuracy ±20%
- Power-Down Mode Selectable (Yes or No)
- 0V Battery Charge Selectable (Permission or Inhibition)
- **Totally Lead-Free & Fully RoHS Compliant (Notes 1 & 2)**
- **Halogen and Antimony Free. "Green" Device (Note 3)**
- **For automotive applications requiring specific change control (i.e. parts qualified to AEC-Q100/101/104/200, PPAP capable, and manufactured in IATF 16949 certified facilities), please [contact us](#) or your local Diodes representative.**
<https://www.diodes.com/quality/product-definitions/>

Notes: 1. No purposely added lead. Fully EU Directive 2002/95/EC (RoHS), 2011/65/EU (RoHS 2) & 2015/863/EU (RoHS 3) compliant.
2. See <https://www.diodes.com/quality/lead-free/> for more information about Diodes Incorporated's definitions of Halogen- and Antimony-free, "Green" and Lead-free.
3. Halogen- and Antimony-free "Green" products are defined as those which contain <900ppm bromine, <900ppm chlorine (<1500ppm total Br + Cl) and <1000ppm antimony compounds.

Pin Assignments

(Top View)

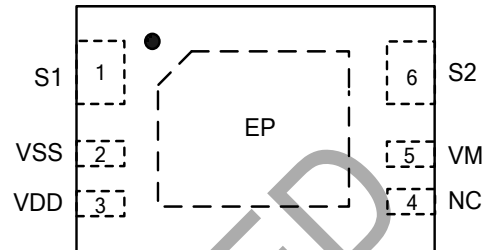

U-DFN2030-6 (Type C)

Applications

- Li+ rechargeable battery packs

Typical Applications Circuit (Note 4)

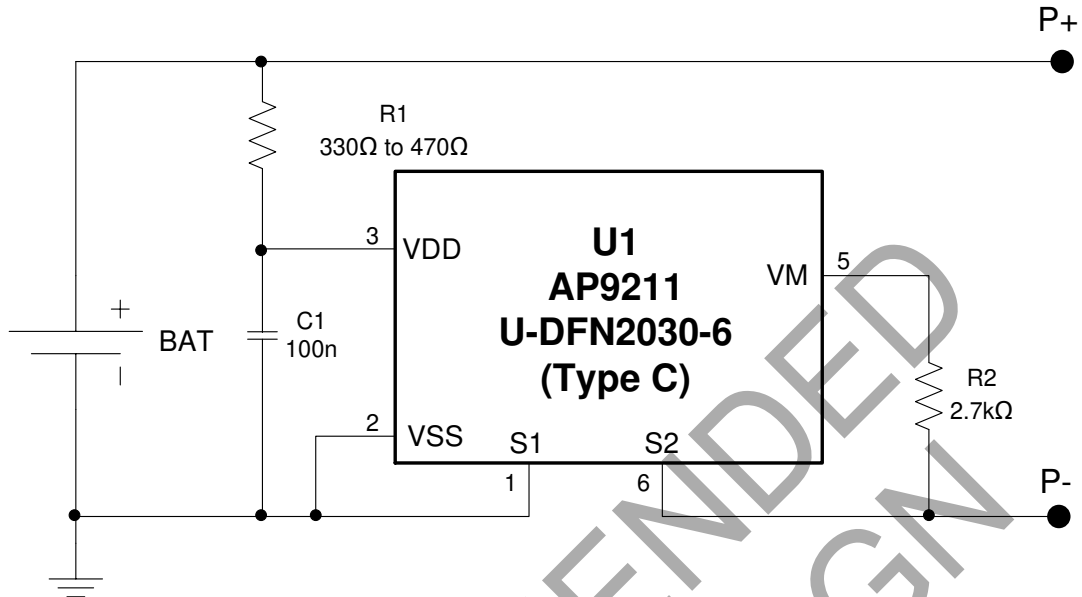

Note: 4. R1 and C1 are used to stabilize the supply voltage of the AP9211. The recommended range of R1 value is 330Ω to 470Ω and C1 value is 10nF to 1000nF, typical value is 100nF. R2 should be connected between P- to VM sense terminal to monitor the status of charger and the charge/discharge current. The R2 should be between 300Ω and 4kΩ, typical value is 2.7kΩ. R1 and R2 are also used as current limit resistors if the battery or charger is connected reversely. Polarity reversing may cause the power consumption of R1 and R2 to go over their power dissipation rating, therefore, R1 and R2 values should be selected appropriately for the actual application. If R2 is more than 4kΩ resistor, charge may not be off due to the voltage drop on R2.

For power-down mode, when first connecting AP9211 system board to the battery, it is necessary to use charger or to short P- to the battery negative polarity. Once the AP9211 is activated, the charger or connection can be removed, otherwise the battery cannot discharge current through system board.

The values selected should follow the recommended typical range mentioned above. It has not been confirmed whether the operation is normal or not in circuits other than the above example of connection. In addition, the example of connection shown above and the typical value do not exactly guarantee proper operation. Please perform the actual application to set the suitable value through your complete evaluation.

Pin Descriptions

Pin Number	Pin Name	Function
1	S1	Source pin of discharging MOSFET, connecting this pin to battery negative pole.
2	VSS	Negative power supply pin
3	VDD	Positive power supply pin, connecting this pin to battery positive pole through R1.
4	NC	Not connected, leave this pin floating.
5	VM	Charger negative input pin, short this pin to S2 pin through R2.
6	S2	Source pin of charging MOSFET, connecting this pin to charge negative input.
EP	D	Thermal PAD is common drain of charge and discharge MOSFET, so in PCB layout, prefer to use large copper area to cover this pad for better thermal dissipation, then leave it open.

Functional Block Diagram

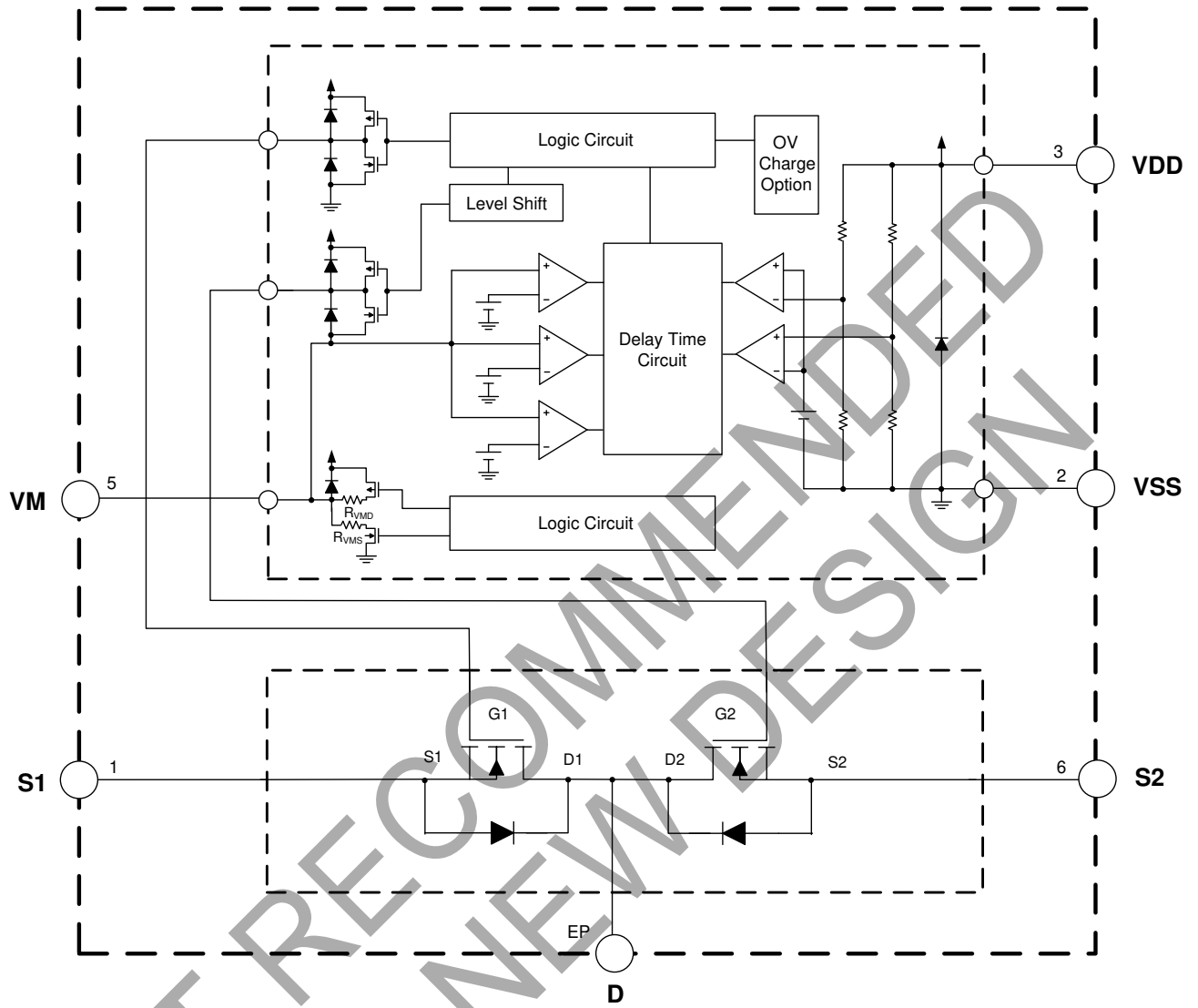

Absolute Maximum Ratings (Notes 5 & 6)

Symbol	Parameter	Rating	Unit
V _{DS}	Supply Voltage (Between VDD and VSS)	-0.3 to 12	V
V _{DM}	Charge Input Voltage (Between VDD and VM for Protection Chip)	-0.3 to 24	V
V _{DSS}	MOSFET Drain-to-Source Voltage	24	V
V _{GSS}	MOSFET Gate-to-Source Voltage	±12	V
I _D	Continuous Drain Current, V _{GS} = 4.5V, T _A = +25°C	9.0	A
	Continuous Drain Current, V _{GS} = 4.5V, T _A = +70°C	7.1	A
P _D	Power Dissipation	1000	mW
T _J	Maximum Junction Temperature	+150	°C
T _{STG}	Storage Temperature Range	-65 to +150	°C
—	ESD (Machine Model)	300	V
—	ESD (Human Body Model)	3000	V

- Notes:
- Stresses greater than those listed under *Absolute Maximum Ratings* can cause permanent damage to the device. These are stress ratings only, and functional operation of the device at these or any other conditions beyond those indicated under *Recommended Operating Conditions* is not implied. Exposure to *Absolute Maximum Ratings* for extended periods can affect device reliability.
 - Ratings apply to ambient temperature at +25°C. The JEDEC High-K board design used to derive this data was a 2 inches x 2 inches multilayer board with 2oz internal power and ground planes and 2oz copper traces on the top and bottom of the board.

Recommended Operating Conditions

Symbol	Parameter	Min	Max	Unit
V _{DS}	Supply Voltage (Between VDD and VSS)	1.5	5.5	V
V _{DM}	Charge Input Voltage (Between VDD and VM)	-0.3	5.5	V
T _A	Operating Ambient Temperature	-40	+85	°C

Electrical Characteristics ($T_A = +25^\circ\text{C}$, $V_{DD} = 3.5\text{V}$, $V_{SS} = 0\text{V}$, $R_1 = 220\Omega$, $R_2 = 1.0\text{k}\Omega$, $C_1 = 100\text{nF}$, unless otherwise specified.)

Symbol	Parameter	Condition	Min	Typ	Max	Unit
V_{CU}	Overcharge Detection Voltage	—	V_{CU} - 0.025	V_{CU}	V_{CU} + 0.025	V
V_{CL}	Overcharge Release Voltage	$V_{CL} \neq V_{CU}$	V_{CL} - 0.050	V_{CL}	V_{CL} + 0.050	V
		$V_{CL} = V_{CU}$	V_{CL} - 0.025	V_{CL}	V_{CL} + 0.025	V
V_{DL}	Overdischarge Detection Voltage	—	V_{DL} - 0.035	V_{DL}	V_{DL} + 0.035	V
V_{DU}	Overdischarge Release Voltage	$V_{DU} \neq V_{DL}$	V_{DU} - 0.100	V_{DU}	V_{DU} + 0.100	V
		$V_{DU} = V_{DL}$	V_{DU} - 0.035	V_{DU}	V_{DU} + 0.035	V
V_{DOC}	Discharge Overcurrent Detection Voltage	—	V_{DOC} - 0.015	V_{DOC}	V_{DOC} + 0.015	V
V_{SHORT}	Load Short-Circuiting Detection Voltage	—	V_{SHORT} - 0.10	V_{SHORT}	V_{SHORT} + 0.10	V
V_{COC}	Charge Overcurrent Detection Voltage	—	V_{COC} - 0.015	V_{COC}	V_{COC} + 0.015	V
I_{CC} (Power-Down Function)						
I_{CC}	Current Consumption During Operation	$V_{DD} = 3.5\text{V}$, $V_M = 0\text{V}$	—	3.0	4.5	μA
I_{PDN}	Current Consumption During Power-Down Mode	$V_{DD} = 1.8\text{V}$, VM Pin Floating	—	—	0.1	μA
I_{CC} (Auto-Wake Up Function)						
I_{CC}	Current Consumption During Operation	$V_{DD} = 3.5\text{V}$, $V_M = 0\text{V}$	—	3	4.5	μA
I_{AUTO}	Current Consumption During Auto-Wake Mode	$V_{DD} = 1.8\text{V}$, VM Pin Floating	—	3.5	5.5	μA
R_{VMD}	Resistance Between VM Pin and VDD Pin	$V_{DD} = 1.8\text{V}$ $V_M = 0\text{V}$	150	300	500	$\text{k}\Omega$
R_{VMS}	Resistance Between VM Pin and VDD Pin	$V_{DD} = 3.5\text{V}$ $V_M = 1.0\text{V}$	10	30	50	$\text{k}\Omega$
V_{0CHA}	0V Battery Charge Starting Charge Voltage	0V battery charging "available"	1.2	—	—	V
V_{0INH}	0V Battery Charge Inhibition Battery Voltage	0V battery charging "unavailable"	—	—	0.45	V
V_{OVCHG}	Overvoltage Charge Detection Voltage	$V_{DD} = 3.5\text{V}$	6.0	8.0	10.0	V
V_{OVCHGR}	Overvoltage Charge Release Voltage	$V_{DD} = 3.5\text{V}$	5.3	7.3	9.3	V
t_{CU}	Overcharge Detection Delay Time	—	$t_{CU} \times 0.8$	t_{CU}	$t_{CU} \times 1.2$	ms
t_{CUR}	Overcharge Release Delay Time	—	$t_{CUR} \times 0.8$	t_{CUR}	$t_{CUR} \times 1.2$	ms
t_{DL}	Overdischarge Detection Delay Time	—	$t_{DL} \times 0.8$	t_{DL}	$t_{DL} \times 1.2$	ms
t_{DLR}	Overdischarge Release Delay Time	—	$t_{DLR} \times 0.8$	t_{DLR}	$t_{DLR} \times 1.2$	ms
t_{DOC}	Discharge Overcurrent Detection Delay Time	—	$t_{DOC} \times 0.8$	t_{DOC}	$t_{DOC} \times 1.2$	ms
t_{DOCR}	Discharge Overcurrent Release Delay Time	—	$t_{DOCR} \times 0.8$	t_{DOCR}	$t_{DOCR} \times 1.2$	ms
t_{SHORT}	Load Short Detection Delay Time	—	$t_{SHORT} \times 0.8$	t_{SHORT}	$t_{SHORT} \times 1.2$	μs
t_{COC}	Charge Overcurrent Detection Delay Time	—	$t_{COC} \times 0.8$	t_{COC}	$t_{COC} \times 1.2$	ms
t_{COCR}	Charge Overcurrent Release Delay Time	—	$t_{COCR} \times 0.8$	t_{COCR}	$t_{COCR} \times 1.2$	ms

Electrical Characteristics

($T_A = -40^{\circ}\text{C}$ to $+85^{\circ}\text{C}$, $V_{DD} = 3.5\text{V}$, $V_{SS} = 0\text{V}$, $R_1 = 220\Omega$, $R_2 = 1.0\text{k}\Omega$, $C_1 = 100\text{nF}$, unless otherwise specified.)

Symbol	Parameter	Condition	Min	Typ	Max	Unit
V_{CU}	Overcharge Detection Voltage	—	V_{CU} - 0.060	V_{CU}	V_{CU} + 0.040	V
V_{CL}	Overcharge Release Voltage	$V_{CL} \neq V_{CU}$	V_{CL} - 0.080	V_{CL}	V_{CL} + 0.065	V
		$V_{CL} = V_{CU}$	V_{CL} - 0.060	V_{CL}	V_{CL} + 0.040	V
V_{DL}	Overdischarge Detection Voltage	—	V_{DL} - 0.080	V_{DL}	V_{DL} + 0.080	V
V_{DU}	Overdischarge Release Voltage	$V_{DU} \neq V_{DL}$	V_{DU} - 0.150	V_{DU}	V_{DU} + 0.190	V
		$V_{DU} = V_{DL}$	V_{DU} - 0.080	V_{DU}	V_{DU} + 0.080	V
V_{DOC}	Discharge Overcurrent Detection Voltage	—	V_{DOC} - 0.021	V_{DOC}	V_{DOC} + 0.024	V
V_{SHORT}	Load Short-Circuiting Detection Voltage	—	V_{SHORT} - 0.34	V_{SHORT}	V_{SHORT} + 0.34	V
V_{COC}	Charge Overcurrent Detection Voltage	—	V_{COC} - 0.040	V_{COC}	V_{COC} + 0.040	V
Icc (Power Down Function)						
I_{CC}	Current Consumption During Operation	$V_{DD} = 3.5\text{V}$, $V_M = 0\text{V}$	—	3.0	7.0	μA
I_{PDN}	Current Consumption During Power-Down Mode	$V_{DD} = 1.8\text{V}$, VM Pin Floating	—	—	1.0	μA
Icc (Auto-Wake Up Function)						
I_{CC}	Current Consumption During Operation	$V_{DD} = 3.5\text{V}$, $V_M = 0\text{V}$	—	3	4.5	μA
I_{AUTO}	Current Consumption During Auto-Wake Mode	$V_{DD} = 1.8\text{V}$, VM Pin Floating	—	6	8	μA
R_{VMD}	Resistance Between VM Pin and VDD Pin	$V_{DD} = 1.8\text{V}$ $V_M = 0\text{V}$	100	300	650	$\text{k}\Omega$
R_{VMS}	Resistance Between VM Pin and VDD Pin	$V_{DD} = 3.5\text{V}$ $V_M = 1.0\text{V}$	5	30	65	$\text{k}\Omega$
V_{0CHA}	0V Battery Charge Starting Charge Voltage	0V battery charging "available"	1.2	—	—	V
V_{0INH}	0V Battery Charge Inhibition Battery Voltage	0V battery charging "unavailable"	—	—	0.3	V
V_{OVCHG}	Overvoltage Charge Detection Voltage	$V_{DD} = 3.5\text{V}$	5.5	8.0	10.5	V
V_{OVCHGR}	Overvoltage Charge Release Voltage	$V_{DD} = 3.5\text{V}$	5.0	7.3	9.5	V
t_{CU}	Overcharge Detection Delay Time	—	$t_{CU} \times 0.6$	t_{CU}	$t_{CU} \times 1.4$	ms
t_{CUR}	Overcharge Release Delay Time	—	$t_{CUR} \times 0.6$	t_{CUR}	$t_{CUR} \times 1.4$	ms
t_{DL}	Overdischarge Detection Delay Time	—	$t_{DL} \times 0.6$	t_{DL}	$t_{DL} \times 1.4$	ms
t_{DLR}	Overdischarge Release Delay Time	—	$t_{DLR} \times 0.6$	t_{DLR}	$t_{DLR} \times 1.4$	ms
t_{DOC}	Discharge Overcurrent Detection Delay Time	—	$t_{DOC} \times 0.6$	t_{DOC}	$t_{DOC} \times 1.4$	ms
t_{DOCR}	Discharge Overcurrent Release Delay Time	—	$t_{DOCR} \times 0.6$	t_{DOCR}	$t_{DOCR} \times 1.4$	ms
t_{SHORT}	Load Short Detection Delay Time	—	$t_{SHORT} \times 0.6$	t_{SHORT}	$t_{SHORT} \times 1.4$	μs
t_{COC}	Charge Overcurrent Detection Delay Time	—	$t_{COC} \times 0.6$	t_{COC}	$t_{COC} \times 1.4$	ms
t_{COCR}	Charge Overcurrent Release Delay Time	—	$t_{COCR} \times 0.6$	t_{COCR}	$t_{COCR} \times 1.4$	ms

Electrical Characteristics (Notes 7 & 8)

($T_A = +25^\circ\text{C}$, $V_{DD} = 3.5\text{V}$, $V_{SS} = 0\text{V}$, $R1 = 220\Omega$, $R2 = 1.0\text{k}\Omega$, $C1 = 100\text{nF}$, unless otherwise specified.)

Symbol	Parameter	Conditions	Min	Typ	Max	Unit
I_{DSS}	Zero Gate Voltage Drain Current	$V_{DS} = 20\text{V}$, $V_{GS} = 0$	—	—	1.0	μA
$R_{SS(ON)1}$	Static Source-Source On-Resistance 1	$V_{DD} = 4.0\text{V}$ $I_D = 1.0\text{A}$	20	27	30	$\text{m}\Omega$
$R_{SS(ON)2}$	Static Source-Source On-Resistance 2	$V_{DD} = 3.9\text{V}$ $I_D = 1.0\text{A}$	21	27	31	$\text{m}\Omega$
$R_{SS(ON)3}$	Static Source-Source On-Resistance 3	$V_{DD} = 3.0\text{V}$ $I_D = 1.0\text{A}$	21	28	33	$\text{m}\Omega$
V_{SD}	Diode Forward Voltage	$V_{GS} = 0\text{V}$ $I_S = 1\text{A}$	—	0.75	1.0	V

Notes: 7. In case of gate-source voltage of charging MOSFET is 0V. In case of gate-source voltage of discharging MOSFET is 0V.
8. These specifications are guaranteed by design - will not be tested in production.

NOT RECOMMENDED
FOR NEW DESIGN

Application Information

Operation Mode

1. Normal Status

The AP9211 monitors the battery voltage between the VDD pin and VSS pin as well as the voltage difference between the VM pin and VSS pin to control battery charging and discharging. When the battery voltage is between overdischarge detection voltage (V_{DL}) and overcharge detection voltage (V_{CU}) as well as when the VM pin voltage is between the charge overcurrent detection voltage (V_{COC}) and discharge overcurrent detection voltage (V_{DOC}), the AP9211 turns on discharging and charging MOSFET. In these conditions, the battery can charge and discharge freely. Also, R_{VMD} does not connect to VDD pin, and R_{VMS} does not connect to VSS pin in this status.

2. Overcharge Status

If the battery voltage is more than V_{CU} during charging status for the overcharge detection delay time (t_{CU}) or longer, the AP9211 turns off the charging MOSFET to stop charging. R_{VMD} and R_{VMS} are not connected in overcharge status.

When VM pin voltage is lower than V_{DOC} and battery voltage falls below V_{CL} , the AP9211 releases from overcharge status. When VM pin voltage is equal or more than V_{DOC} and battery voltage falls below V_{CU} , the AP9211 releases from overcharge status.

3. Overdischarge Status

If the battery voltage is less than V_{DL} during discharging status for the overdischarge detection delay time (t_{DL}) or longer, the AP9211 turns off the discharging MOSFET to stop discharging. In overdischarge status, R_{VMD} is connected to VDD and VM pin voltage is pulled up to VDD by R_{VMD} , but R_{VMS} is not connected. For power-down mode version, the AP9211 recovers normal status from overdischarge status only by charging the battery through the charger.

When VM pin voltage to VSS pin voltage is less than typical $-0.7V$, and the battery voltage rises over V_{DL} , the AP9211 releases from overdischarge status. If VM pin voltage to VSS pin voltage is higher than typical $-0.7V$, the AP9211 releases from overdischarge status until the battery voltage rises over V_{DU} .

For auto-wake up version AP9211SA, the device recovers to normal status from overdischarge status if either of these two conditions are satisfied:

If charger is connected: The AP9211SA overdischarge status is released in the same way as described above in AP9211S Overdischarge Status section.

If no charger is connected: 1) The battery voltage reaches the overdischarge release voltage (V_{DU}) or higher.
2) Maintains continuous time more than overdischarge release delay time t_{DLR} .

4. Discharge Overcurrent and Short-Current Status

When battery is in discharge overcurrent status, if the voltage of the VM pin to VSS pin is equal or more than V_{DOC} to V_{SHORT} and detection lasts for the discharge overcurrent detection delay time (t_{DOC}) or longer, the AP9211 turns off the discharging MOSFET to stop discharging.

When the battery is in short-current status, if the voltage of the VM pin to VSS pin is equal to or more than V_{SHORT} , and the detection lasts for the short current detection delay time or longer, the AP9211 turns off the discharge MOSFET to stop discharging.

In discharge overcurrent or short-current status, R_{VMS} is connected to VSS, but R_{VMD} is not connected. The voltage of VM pin is almost equal to VDD as long as the load is connected. When the load is disconnected, the voltage of VM pin becomes almost equal to VSS (due to R_{VMS} being connected) and then the AP9211 releases from discharge overcurrent or short current status.

5. Charge Overcurrent Status

When the battery is in charge current status, if the voltage of the VM pin to VSS pin is equal to or less than V_{COC} , and the detection continues for the charge overcurrent detection delay time (t_{COC}) or longer, the AP9211 turns off the charging MOSFET to stop charging.

Application Information (continued)

6. 0V Battery Charging Function (Option)

This function is available as an option and can be factory set internally. AP9211 has this function built in. 0V charging function permits charger to recharge the battery whose voltage is 0V due to self-discharge. If 0V charging function is not present, the device prevents the charger to recharge the battery whose voltage is 0V due to self-discharge. If a device without 0V charging function is required, contact Diodes sales team.

7. Overvoltage Charger Detection Circuit

This function is used to monitor the charger voltage between the VDD pin and VM pin, and when this voltage exceeds overvoltage charger detection voltage (8.0V Typ.), the AP9211 turns off charging MOSFET. When this voltage drops below overvoltage charger release voltage (7.3V Typ.), it then turns on charging MOSFET. There are no delay times set for detection and release.

8. Power-Down Mode or Auto-Wake-up Function (Option)

In a device with power-down function, during power-down mode, the device enters the overdischarge status. The IC enters sleep mode and the current consumption becomes very low, typically 0.1 μ A. To release from power-down status to the normal status, charger connection is required.

In device with auto-wake-up mode, the IC remains active in the overdischarge state. The IC is released into the normal state by the operation that increases the battery voltage more than overdischarge release voltage.

NOT RECOMMENDED
FOR NEW DESIGN

Application Information (Timing Chart)

1. Overcharge and Overdischarge Detection

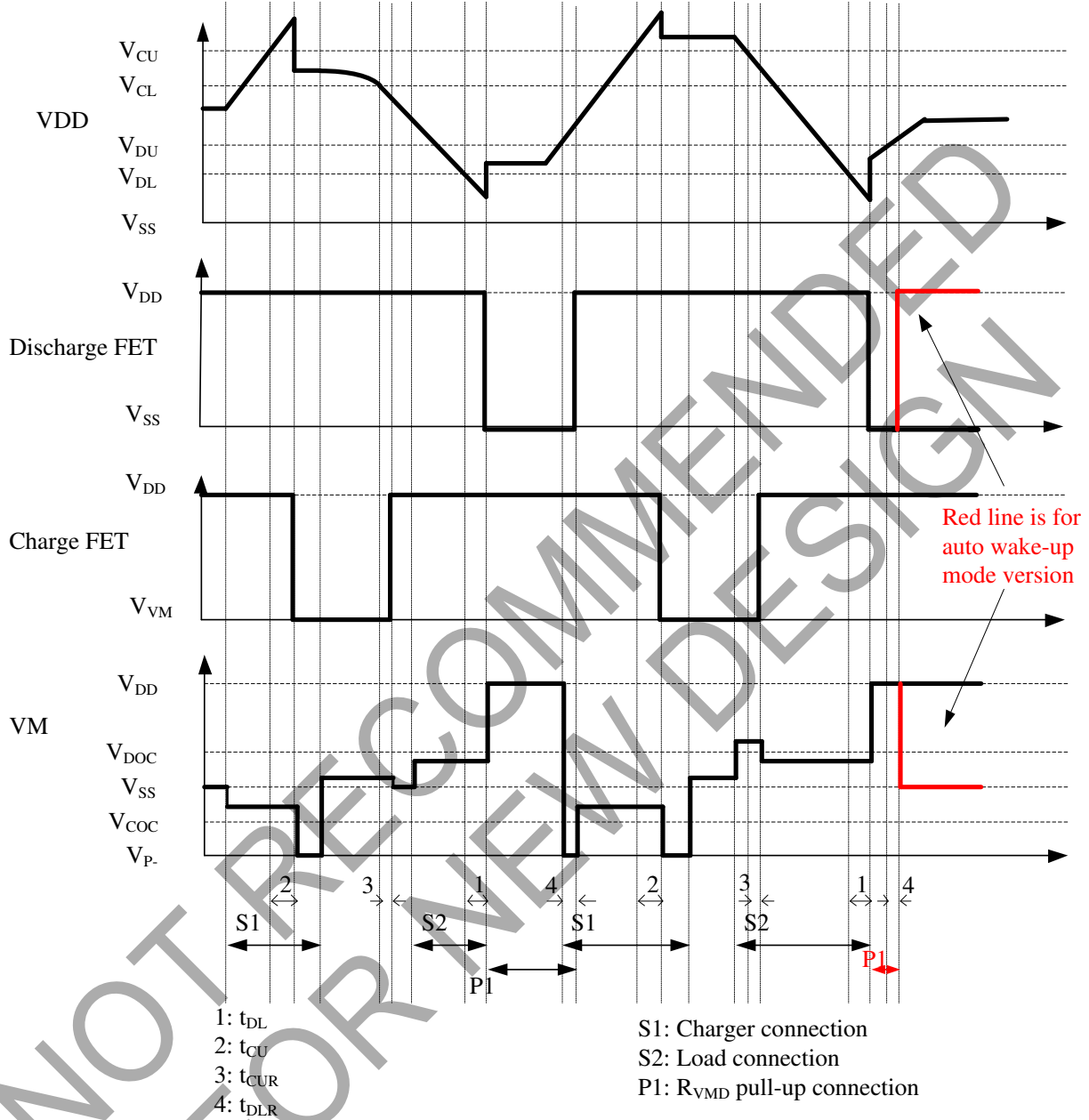

Application Information (Timing Chart) (continued)

2. Discharge Overcurrent Detection

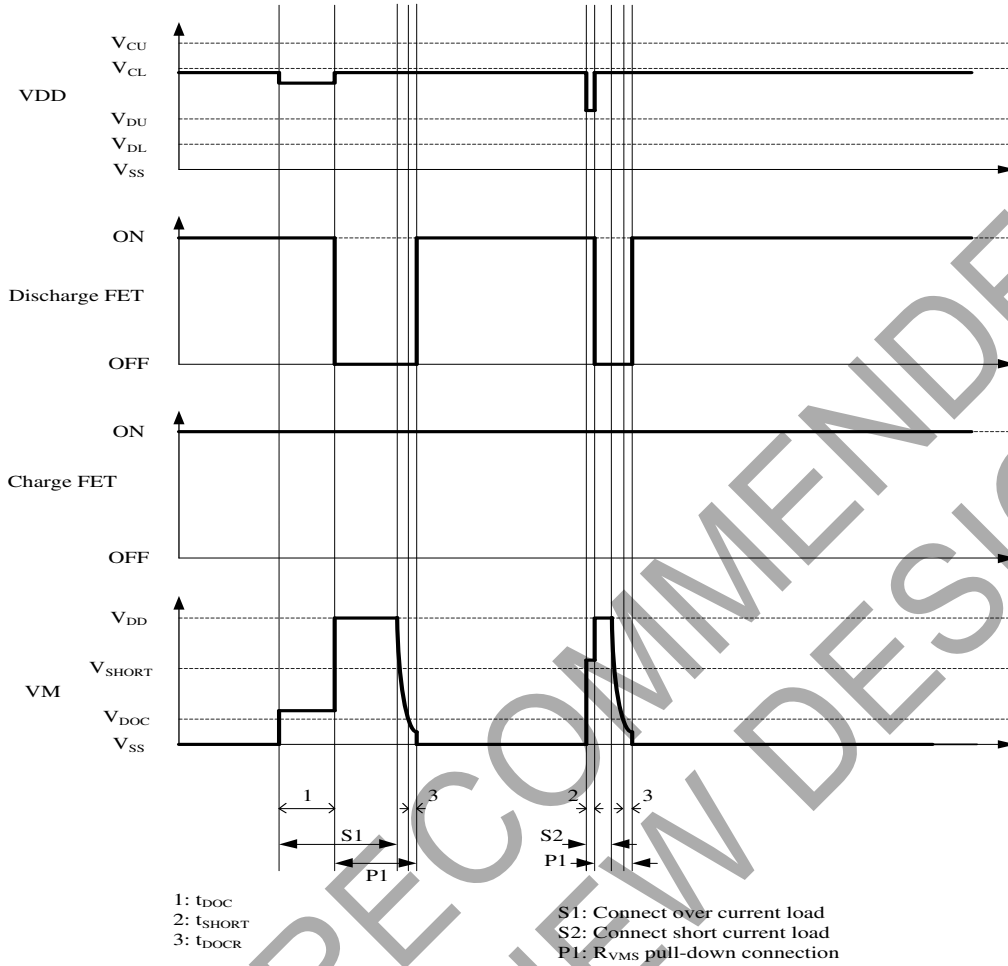

NOT RECOMMENDED FOR NEW DESIGN

Application Information (Timing Chart) (continued)

3. Charge Overcurrent Detection

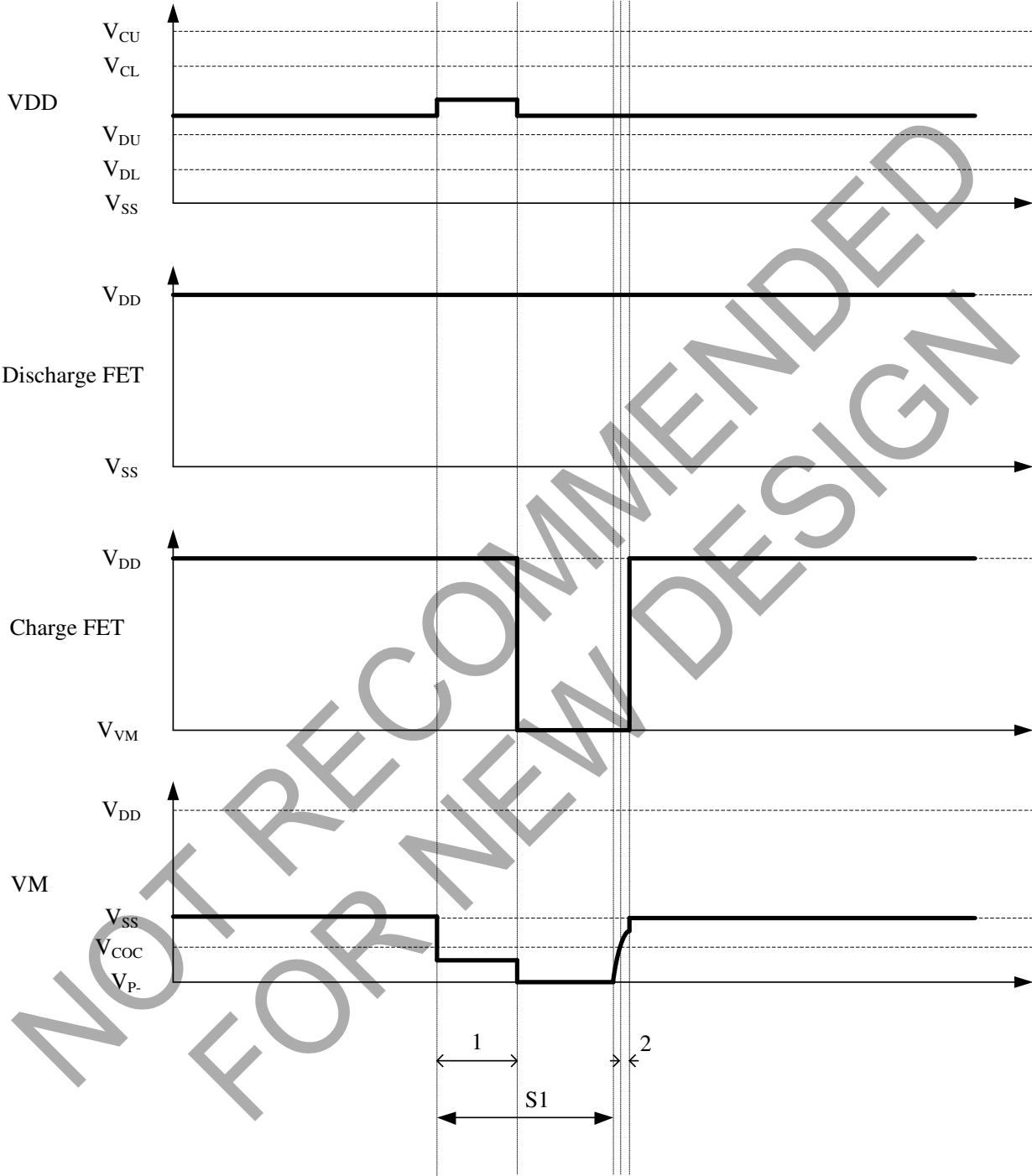

1: t_{COC}
2: t_{COCR}

S1: Connect over current charger

Ordering Information

AP9211XX - X - X - X

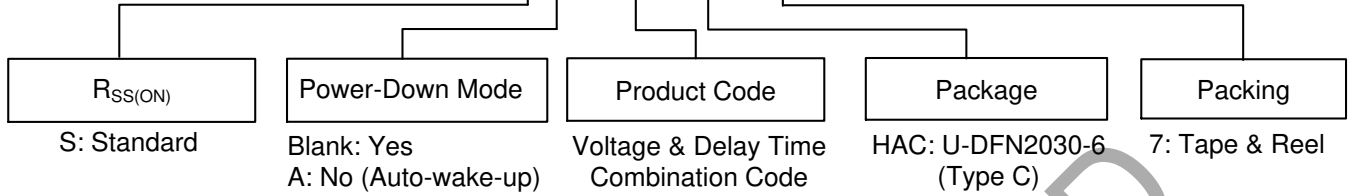

Part Number	Package Code	Package	Packing	
			Qty.	Carrier
AP9211XX-XX-HAC-7	HAC	U-DFN2030-6 (Type C)	3000	7" Tape and Reel

Voltage Combination (Note 9)

Part Number	Overcharge Detection Voltage V _{CU}	Overcharge Release Voltage V _{CL}	Over-discharge Detection Voltage V _{DL}	Over-discharge Release Voltage V _{DU}	Discharge Overcurrent Detection Voltage V _{DOC}	Load Short Detection Voltage V _{SHORT}	Charge Overcurrent Detection Voltage V _{COCC}	Overvoltage Charger Detection Voltage V _{OVCHG}	Overvoltage Charger Release Voltage V _{OVCHGR}	Power-Down Function	Overcharge Protection Mode	0V Battery Charge Function
AP9211XX-AA-HAC-7	4.375V	4.175V	2.500V	2.900V	0.150V	0.700V	-0.150V	8.0V	7.3V	Selectable	Auto Release	Permission
AP9211XX-AB-HAC-7	4.425V	4.225V	2.500V	2.900V	0.150V	0.700V	-0.150V	8.0V	7.3V	Selectable	Auto Release	Permission
AP9211XX-AC-HAC-7	4.375V	4.175V	2.500V	2.900V	0.095V	0.700V	-0.095V	8.0V	7.3V	Selectable	Auto Release	Permission
AP9211XX-AD-HAC-7	4.375V	4.175V	2.500V	2.900V	0.120V	0.700V	-0.120V	8.0V	7.3V	Selectable	Auto Release	Permission
AP9211XX-AE-HAC-7	4.200V	4.100V	2.500V	3.000V	0.300V	0.550V	-0.100V	8.0V	7.3V	Selectable	Auto Release	Permission
AP9211XX-AF-HAC-7	4.375V	4.175V	2.500V	2.900V	0.180V	0.700V	-0.180V	8.0V	7.3V	Selectable	Auto Release	Permission
AP9211XX-AG-HAC-7	4.375V	4.175V	2.500V	2.900V	0.075V	0.700V	-0.075V	8.0V	7.3V	Selectable	Auto Release	Permission
AP9211XX-AH-HAC-7	4.425V	4.225V	2.500V	2.900V	0.075V	0.700V	-0.075V	8.0V	7.3V	Selectable	Auto Release	Permission
AP9211XX-AI-HAC-7	4.500V	4.300V	2.400V	2.800V	0.150V	0.700V	-0.075V	8.0V	7.3V	Selectable	Auto Release	Permission
AP9211XX-AJ-HAC-7	4.375V	4.175 V	2.400V	2.800V	0.125V	0.700V	- 0.125V	8.0V	7.3V	Selectable	Auto Release	Permission
AP9211XX-AK-HAC-7	4.250V	4.050 V	2.400V	3.000V	0.150V	0.700V	- 0.150V	8.0V	7.3V	Selectable	Auto Release	Permission
AP9211XX-AL-HAC-7	4.275V	4.175V	2.300V	2.400V	0.180V	0.700V	-0.180V	8.0V	7.3V	Selectable	Auto Release	Permission
AP9211XX-AM-HAC-7	4.375V	4.175V	2.300V	2.400V	0.180V	0.700V	-0.180V	8.0V	7.3V	Selectable	Auto Release	Permission
AP9211XX-AN-HAC-7	4.225V	4.025V	3.200V	3.400V	0.060V	0.450V	-0.060V	8.0V	7.3V	Selectable	Auto Release	Permission
AP9211XX-DD-HAC-7	4.375V	4.175V	2.500V	2.900V	0.120V	0.700V	-0.120V	8.0V	7.3V	Selectable	Auto Release	Prohibition
AP9211XX-DH-HAC-7	4.425V	4.225V	2.500V	2.900V	0.075V	0.700V	-0.075V	8.0V	7.3V	Selectable	Auto Release	Prohibition
AP9211XX-DL-HAC-7	4.275V	4.175V	2.300V	2.400V	0.180V	0.700V	-0.180V	8.0V	7.3V	Selectable	Auto Release	Prohibition
AP9211XX-CR-HAC-7	4.425V	4.225V	2.800V	3.000V	0.130V	0.500V	0.130V	8.0V	7.3V	Selectable	Auto Release	Prohibition
AP9211XX-EA-HAC-7	4.475V	4.275V	2.500V	2.900V	0.150V	0.500V	-0.150V	8.0V	7.3V	Selectable	Auto Release	Permission

Note: 9. If any other voltage combinations are needed, please contact the local sales office.

Ordering Information (continued)

AP9211 Delay Time Combination

Part Number	Overcharge Detection Delay Time <i>t_{CU}</i>	Overcharge Release Delay Time <i>t_{CUr}</i>	Overdischarge Detection Delay Time <i>t_{DL}</i>	Overdischarge Release Delay Time <i>t_{DLr}</i>	Discharge Overcurrent Detection Delay Time <i>t_{BOC}</i>	Discharge Overcurrent Release Delay Time <i>t_{BOCr}</i>	Charge Overcurrent Detection Delay Time <i>t_{COc}</i>	Charge Overcurrent Release Delay Time <i>t_{COCr}</i>	Load Short Detection Delay Time <i>t_{SHORT}</i>
AP9211XX-XX-HAC-7	1.0s	2.0ms	115ms	2.0ms	10.0ms	2.0ms	10.0ms	2.0ms	360µs

Marking Information

(Top View)

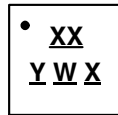

XX : Identification Code
Y : Year : 0 to 9
W : Week : A to Z : week 1 to 26;
 a to z : week 27 to 52; z represents
 week 52 and 53
X : A to Z : Internal Code

Part Number	Package	Identification Code
AP9211S-AA-HAC-7	U-DFN2030-6 (Type C)	P5
AP9211S-AB-HAC-7	U-DFN2030-6 (Type C)	P6
AP9211S-AC-HAC-7	U-DFN2030-6 (Type C)	6B
AP9211S-AD-HAC-7	U-DFN2030-6 (Type C)	6C
AP9211S-AE-HAC-7	U-DFN2030-6 (Type C)	6D
AP9211S-AF-HAC-7	U-DFN2030-6 (Type C)	6E
AP9211S-AG-HAC-7	U-DFN2030-6 (Type C)	6F
AP9211S-AH-HAC-7	U-DFN2030-6 (Type C)	6G
AP9211S-AI-HAC-7	U-DFN2030-6 (Type C)	6H
AP9211S-AJ-HAC-7	U-DFN2030-6 (Type C)	6Y
AP9211S-AK-HAC-7	U-DFN2030-6 (Type C)	6Z
AP9211S-AL-HAC-7	U-DFN2030-6 (Type C)	5T
AP9211S-AM-HAC-7	U-DFN2030-6 (Type C)	5U
AP9211S-AN-HAC-7	U-DFN2030-6 (Type C)	5V
AP9211S-CR-HAC-7	U-DFN2030-6 (Type C)	5W
AP9211S-DD-HAC-7	U-DFN2030-6 (Type C)	5Z
AP9211S-DH-HAC-7	U-DFN2030-6 (Type C)	8A
AP9211S-DL-HAC-7	U-DFN2030-6 (Type C)	8B
AP9211SA-AA-HAC-7	U-DFN2030-6 (Type C)	M3
AP9211SA-AB-HAC-7	U-DFN2030-6 (Type C)	M4
AP9211SA-AC-HAC-7	U-DFN2030-6 (Type C)	M6
AP9211SA-AD-HAC-7	U-DFN2030-6 (Type C)	M7
AP9211SA-AE-HAC-7	U-DFN2030-6 (Type C)	M8
AP9211SA-AF-HAC-7	U-DFN2030-6 (Type C)	N3
AP9211SA-AG-HAC-7	U-DFN2030-6 (Type C)	N4
AP9211SA-AH-HAC-7	U-DFN2030-6 (Type C)	N6
AP9211SA-AI-HAC-7	U-DFN2030-6 (Type C)	N7
AP9211SA-AJ-HAC-7	U-DFN2030-6 (Type C)	N8
AP9211SA-AK-HAC-7	U-DFN2030-6 (Type C)	NE
AP9211SA-AL-HAC-7	U-DFN2030-6 (Type C)	7X
AP9211SA-AM-HAC-7	U-DFN2030-6 (Type C)	P7
AP9211SA-AN-HAC-7	U-DFN2030-6 (Type C)	P8
AP9211SA-CR-HAC-7	U-DFN2030-6 (Type C)	7Y
AP9211SA-DD-HAC-7	U-DFN2030-6 (Type C)	7Z
AP9211SA-DL-HAC-7	U-DFN2030-6 (Type C)	7V

Package Outline Dimensions

Please see <http://www.diodes.com/package-outlines.html> for the latest version.

U-DFN2030-6 (Type C)

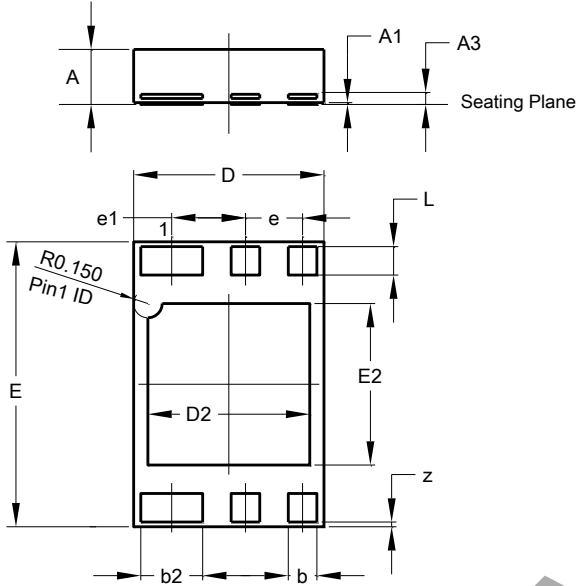

U-DFN2030-6 (Type C)			
Dim	Min	Max	Typ
A	0.50	0.60	--
A1	0.00	0.05	0.02
A3	--	--	0.127
b	0.25	0.35	0.30
b2	0.60	0.70	0.65
D	1.90	2.10	2.00
D2	1.60	1.80	1.70
E	2.90	3.10	3.00
E2	1.60	1.80	1.70
e	--	--	0.60
e1	--	--	0.775
L	0.25	0.35	0.30
z	0.0500 Ref		
All Dimensions in mm			

Suggested Pad Layout

Please see <http://www.diodes.com/package-outlines.html> for the latest version.

U-DFN2030-6 (Type C)

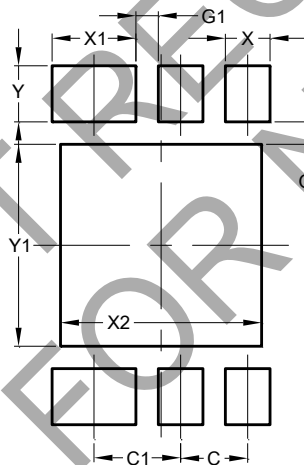

Dimensions	Value (in mm)
C	0.600
C1	0.775
G	0.200
G1	0.200
X	0.400
X1	0.750
X2	1.800
Y	0.500
Y1	1.800

IMPORTANT NOTICE

1. DIODES INCORPORATED (Diodes) AND ITS SUBSIDIARIES MAKE NO WARRANTY OF ANY KIND, EXPRESS OR IMPLIED, WITH REGARDS TO ANY INFORMATION CONTAINED IN THIS DOCUMENT, INCLUDING, BUT NOT LIMITED TO, THE IMPLIED WARRANTIES OF MERCHANTABILITY, FITNESS FOR A PARTICULAR PURPOSE OR NON-INFRINGEMENT OF THIRD PARTY INTELLECTUAL PROPERTY RIGHTS (AND THEIR EQUIVALENTS UNDER THE LAWS OF ANY JURISDICTION).
2. The Information contained herein is for informational purpose only and is provided only to illustrate the operation of Diodes' products described herein and application examples. Diodes does not assume any liability arising out of the application or use of this document or any product described herein. This document is intended for skilled and technically trained engineering customers and users who design with Diodes' products. Diodes' products may be used to facilitate safety-related applications; however, in all instances customers and users are responsible for (a) selecting the appropriate Diodes products for their applications, (b) evaluating the suitability of Diodes' products for their intended applications, (c) ensuring their applications, which incorporate Diodes' products, comply the applicable legal and regulatory requirements as well as safety and functional-safety related standards, and (d) ensuring they design with appropriate safeguards (including testing, validation, quality control techniques, redundancy, malfunction prevention, and appropriate treatment for aging degradation) to minimize the risks associated with their applications.
3. Diodes assumes no liability for any application-related information, support, assistance or feedback that may be provided by Diodes from time to time. Any customer or user of this document or products described herein will assume all risks and liabilities associated with such use, and will hold Diodes and all companies whose products are represented herein or on Diodes' websites, harmless against all damages and liabilities.
4. Products described herein may be covered by one or more United States, international or foreign patents and pending patent applications. Product names and markings noted herein may also be covered by one or more United States, international or foreign trademarks and trademark applications. Diodes does not convey any license under any of its intellectual property rights or the rights of any third parties (including third parties whose products and services may be described in this document or on Diodes' website) under this document.
5. Diodes' products are provided subject to Diodes' Standard Terms and Conditions of Sale (<https://www.diodes.com/about/company/terms-and-conditions/terms-and-conditions-of-sales/>) or other applicable terms. This document does not alter or expand the applicable warranties provided by Diodes. Diodes does not warrant or accept any liability whatsoever in respect of any products purchased through unauthorized sales channel.
6. Diodes' products and technology may not be used for or incorporated into any products or systems whose manufacture, use or sale is prohibited under any applicable laws and regulations. Should customers or users use Diodes' products in contravention of any applicable laws or regulations, or for any unintended or unauthorized application, customers and users will (a) be solely responsible for any damages, losses or penalties arising in connection therewith or as a result thereof, and (b) indemnify and hold Diodes and its representatives and agents harmless against any and all claims, damages, expenses, and attorney fees arising out of, directly or indirectly, any claim relating to any noncompliance with the applicable laws and regulations, as well as any unintended or unauthorized application.
7. While efforts have been made to ensure the information contained in this document is accurate, complete and current, it may contain technical inaccuracies, omissions and typographical errors. Diodes does not warrant that information contained in this document is error-free and Diodes is under no obligation to update or otherwise correct this information. Notwithstanding the foregoing, Diodes reserves the right to make modifications, enhancements, improvements, corrections or other changes without further notice to this document and any product described herein. This document is written in English but may be translated into multiple languages for reference. Only the English version of this document is the final and determinative format released by Diodes.
8. Any unauthorized copying, modification, distribution, transmission, display or other use of this document (or any portion hereof) is prohibited. Diodes assumes no responsibility for any losses incurred by the customers or users or any third parties arising from any such unauthorized use.
9. This Notice may be periodically updated with the most recent version available at <https://www.diodes.com/about/company/terms-and-conditions/important-notice>

The Diodes logo is a registered trademark of Diodes Incorporated in the United States and other countries.
All other trademarks are the property of their respective owners.
© 2023 Diodes Incorporated. All Rights Reserved.

www.diodes.com