

THIS DRAWING IS UNPUBLISHED. RELEASED FOR PUBLICATION
 © COPYRIGHT - By - ALL RIGHTS RESERVED.

LOC	DIST	REVISIONS			
P	LTR	DESCRIPTION	DATE	DWN	APVD
AF	50	K1	ECR-13-017177	05NOV13	PKS RRP

IDENTIFICATION NUMBER 5 FOR
MAGNET WIRE RANGE

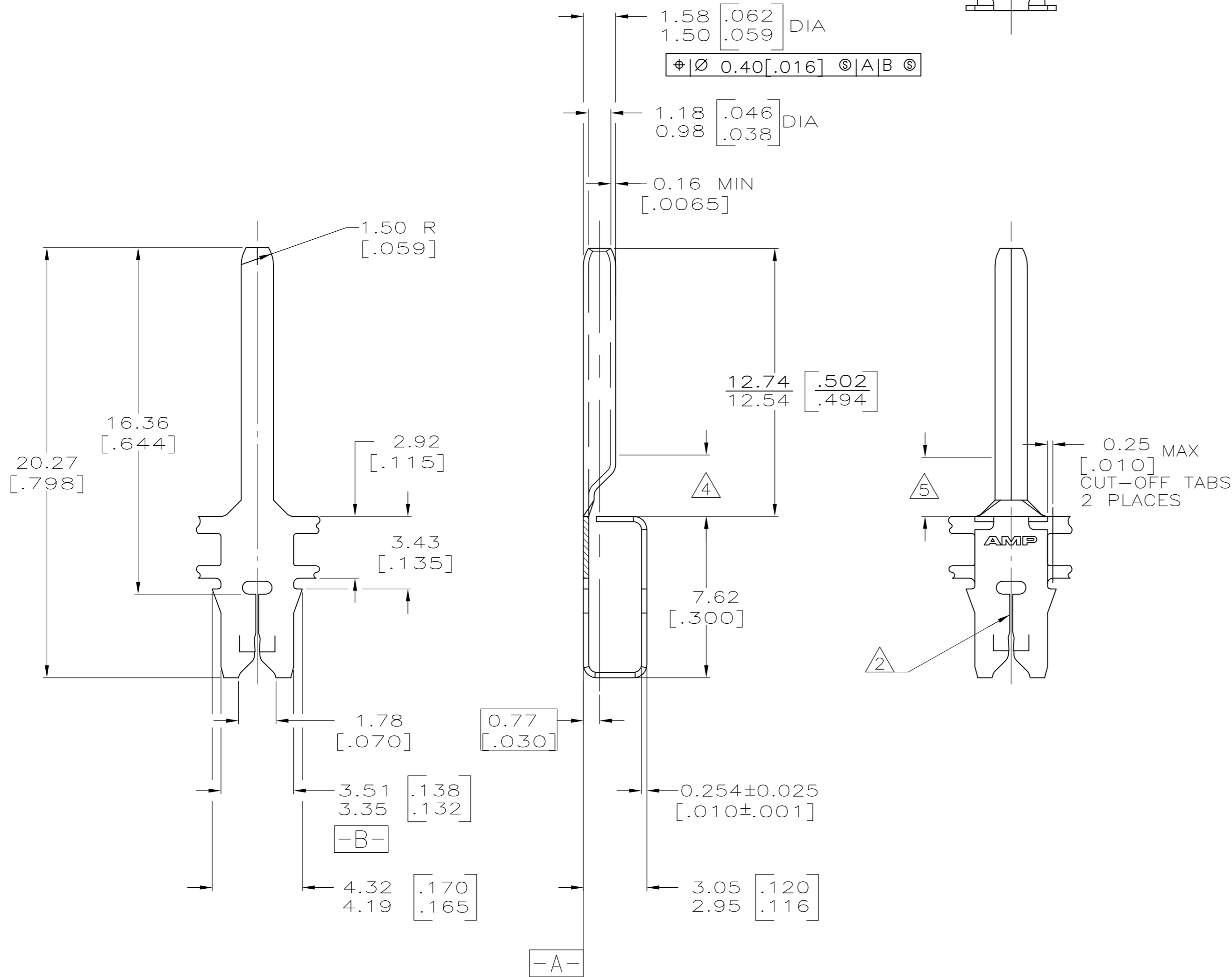
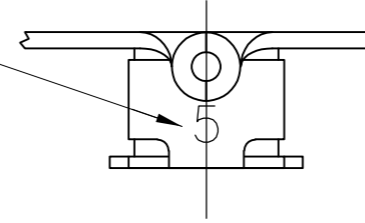

- 1 CONTINUOUS STRIP ON REELS (NO SPLICES) WITH TERMINALS LOCATED ON 5.59±0.08 [.220±.003] CENTERS.
- 2 SLOT TERMINATES EITHER SINGLE OR DOUBLE COPPER MAGNET WIRES OF THE SAME SIZE, 0.23-0.32mm [#31-#28] AWG.
- 3 PRE-TIN PLATED PER MIL-T-10727 OVER PRE-COPPER UNDERPLATE PER MIL-C-14550, WITH ANTI-CORROSION LUBE COATING.
- 4 2.90 [.114] MIN DISTANCE FOR BASE OF PIN TO BE CLOSED FOR INJECTION MOLDING.
- 5 2.80 [.110] MAX DISTANCE FOR TRANSITION FROM FLAT TO ROUND.

63722-1

THIS DRAWING IS A CONTROLLED DOCUMENT.		DWN MICHAEL S. FEHER 6/18/93		
DIMENSIONS: INCHES		CHK LORI A. MAYER 7/12/93		
TOLERANCES UNLESS OTHERWISE SPECIFIED:		APVD KURT A. RANDOLPH 7/12/93	NAME PIN, 1.52 [.060] DIA, MAG-MATE™	
0 PLC ± -		PRODUCT SPEC 108-2012	SIZE A2	CAGE CODE 00779
1 PLC ± -		APPLICATION SPEC 114-2046	DRAWING NO C=63722	RESTRICTED TO -
2 PLC ± 0.25 [.010]		MATERIAL BRASS	SCALE 6:1	SHEET 1 OF 1
3 PLC ± -		FINISH - 3	REV K1	
4 PLC ± -		CUSTOMER DRAWING		
ANGLES ± 1°				