

MTAH, MTAS, and MTAZ Series



- Industry Standard Package
- + 3.30VDC or + 5.00VDC
- RoHS Compliant Available
- Up to 800.000MHZ



ELECTRICAL SPECIFICATIONS:

Output		HCMOS	Clipped Sinewave	Sinewave
Frequency Range	Fund or 3 rd OT	1.000kHz to 180.000MHZ	1.000kHz to 180.000MHZ	1.000kHz to 180.000MHZ
	PLL	75.000kHz to 200.000MHZ	75.000kHz to 800.000MHZ	75.000kHz to 800.000MHZ
Load		10k Ohms // 15pF	10k Ohms // 15pF	50 Ohms
Supply Current		35mA max	3mA max	35mA max
Output Level		Logic "1" = 90% of Vdd min Logic "0" = 10% of Vdd max	1.0V p-p min	0 dBm min
Symmetry		40%/60% at 50% of Waveform	N/A	N/A
Freq. Stability vs Temp (Note 1)	(See Frequency Stability vs Temperature Table)			
Freq. Stability vs Aging	±1 ppm per year max			
Freq. Stability vs Voltage	±0.3 ppm with a 5% change in Vdd			
Freq. Stability vs Load	±0.3 ppm with a 10% change in Load			
Storage Temperature	-40°C to +85°C			
Supply Voltage (Vdd)		+3.3VDC ±5%	+5.0VDC ±5%	
Control Voltage with VC option		+1.65VDC ±1.50VDC Positive Slope	+2.50VDC ±2.00VDC Positive Slope	
Pin 1 Connection				
No Connection	No Connection			
VC Option	±10 ppm min			
Mechanical Trimmer when Specified	±3 ppm min If no mechanical trimmer is specified, trimmer may still be present depending on frequency stability option.			

Note 1: If no mechanical trimmer, oscillator frequency shall be ±1 ppm at +25°C ±3°C at time of shipment.

PART NUMBER GUIDE:

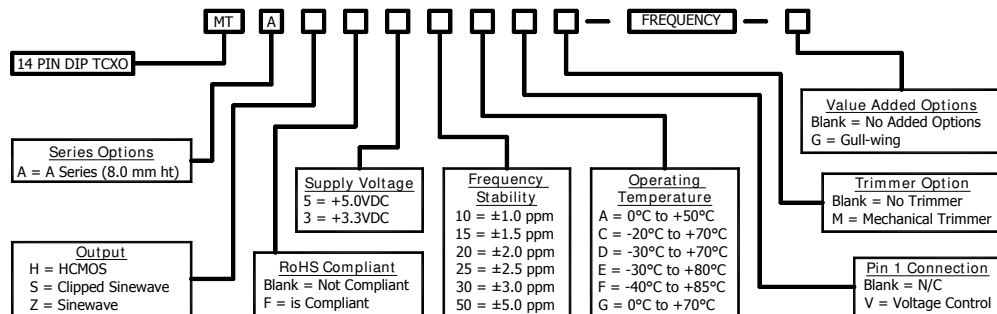

Please Consult with MMD Sales Department for any other Parameters or Options.

MMD Components, 30400 Esperanza, Rancho Santa Margarita, CA, 92688
 Phone: (949) 709-5075, Fax: (949) 709-3536, www.mmdcomp.com
 Sales@mmdcomp.com

FREQUENCY STABILITY vs TEMPERATURE TABLE:

Code	Stability	10	15	20	25	30	50
	Temp	±1.0ppm	±1.5ppm	±2.0ppm	±2.5ppm	±3.0ppm	±5.0ppm
A	0°C TO +50°C	•	•	•	•	•	•
G	0°C TO +70°C		•	•	•	•	•
C	-20°C TO +70°C			•	•	•	•
D	-30°C TO +70°C				•	•	•
E	-30°C TO +80°C				•	•	•
F	-40°C TO +85°C						•

• = Available

= Consult with the Manufacturer

MECHANICAL DIMENSIONS:

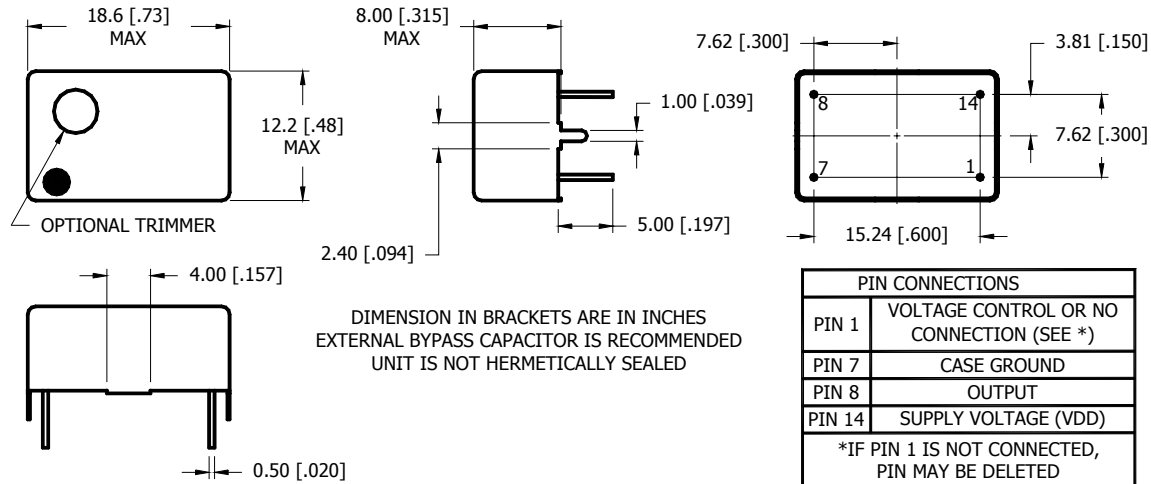

ENVIRONMENT / MECHANICAL:

Shock	MIL-STD-883, Method 2002, Condition B
Solderability	MIL-STD-883, Method 2003
Solvent Resistance	MIL-STD-883, Method 215
Vibration	MIL-STD-883, Method 2007, Condition A

PHASE NOISE:

10 Hz	-65 dBc/HZ
100 Hz	-85 dBc/HZ
1 kHz	-115 dBc/HZ
10 kHz	-127 dBc/HZ

MARKING:

Line 1 = MXXXXX

M = MMD COMPONENTS
XXXXX = Frequency in MHZ

Line 2 = SYMMML

S = Internal Code
YYMM = 4 Digit Date Code (Year / Month)
L = Denotes RoHS Compliant

Line 3 = XXXXX

Internal use only
May vary with lots

Dot to denote Pin 1

MMD Components, 30400 Esperanza, Rancho Santa Margarita, CA, 92688
Phone: (949) 709-5075, Fax: (949) 709-3536, www.mmdcomp.com
Sales@mmdcomp.com