

This document is the property of Amphenol Corporation and is delivered on the express condition that is not to be disclosed, reproduced or used, in whole or in part, for manufacture or sale by anyone other than Amphenol Corporation without its prior consent, and that no right is granted to disclose or to use any information in this document.
The marking on this product doesn't contain environmental hazardous materials per directive 2011/65/EU for RoHS compliant.



ORIGINAL



		REVISIONS		
SYM	ECN No.	DESCRIPTION	DATE	APPROVED
A	NE-17085	RELEASE TO PRODUCTION	04/24/2017	Roger Tsai
B	NE-19115	CHANGE CD PIN SHORT TO LONG / ADD CD PIN DIMENSION 11.1mm +0.08/-0.05/ADD A LASER SIGN FOR CARD INSERTION ON THE SHELL	06/27/2019	Roger Tsai

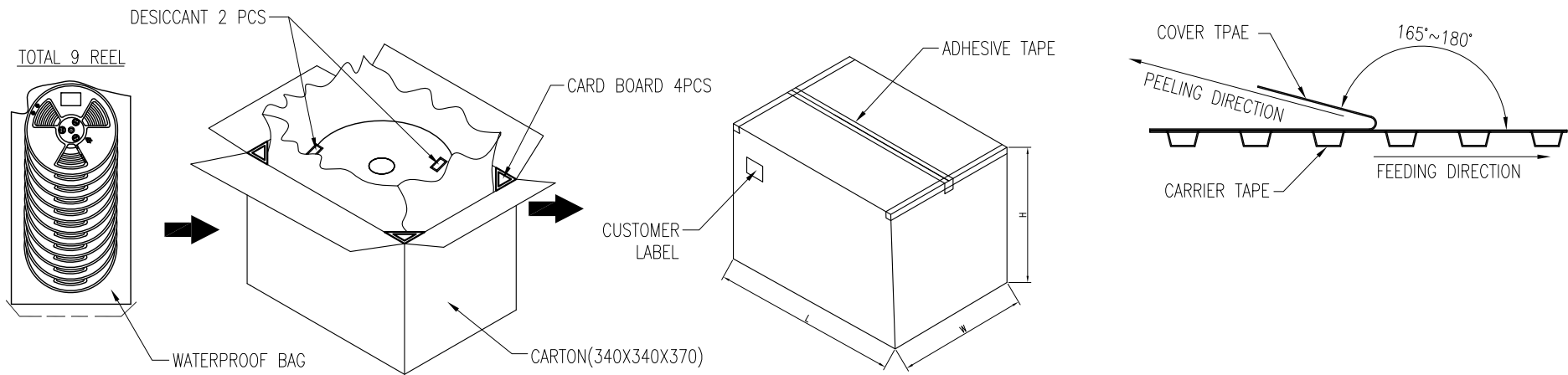
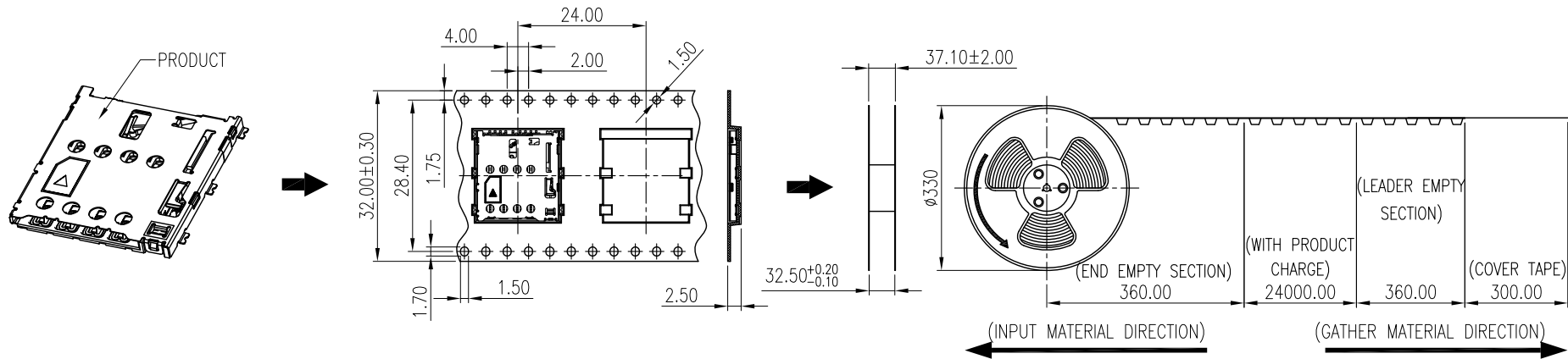

- NOTES:
- CARRIER TAPE MATERIAL: Transparent Polystyrene.(HJ-TR-500)
 - PEELING SPEED: 300mm/MINUTE
 - COVER TAPE PEELING STRENGTH: 20gf~100gf. AT 300mm/Min
 - PACKING QUANTITY:
 - 1000 PCS PRODUCT/REEL.
 - 9 PCS REEL/CARTON.
 - 9000 PCS PRODUCT/CARTON.

TOLERANCE		APPROVALS		DATE	TITLE MICRO SIM CARD CONNECTOR 8 POS., 2.54PITCH, 1.42H SMT PUSH/PUSH TYPE FOR CISCO ONLY	Amphenol®				
X.		DRAWN	Karen Su	06/27/2019		Amphenol Corporation Amphenol Taiwan Corporation				
X.X	±0.30	CHECKED	Aqua Chou	06/27/2019	UNIT	mm	SIZE	A3	PART No.	G85B2X10XB1HR
X.XX	±0.20	APPROVED	Roger Tsai	06/27/2019	SCALE	NA	SHEET	2 OF 2	DWG No.	G85B2X10XB1HR
X.XXX	±0.10	DWG TYPE	CUST DWG	PROJECT CODE	OTHER				REV.	B