

CAPPED THRU HOLE 12-18 AWG: 00-9177

General Information



KYOCERA AVX developed the initial SMT discrete wire IDC connector 5 years ago for 26- 28AWG wires. Since then, we have seen this Wire-to-Board (WTB) contact technology spread to multiple wire gauges and multiple configurations; standard connectors, capped connectors and single contacts. All of which addresses specific application or cost parameters set forth by our customer in demanding industrial, transportation or commercial applications. The heart of the IDC connector is the true “gas tight” WTB termination that is achieved once the wire is inserted between the dual phosphor bronze contact tines. These opposing tines provide enough spring characteristics to allow the termination to remain stable over extreme levels of temperature, shock and vibration.

The new 9177-600 family of contacts incorporates all of the above mentioned capabilities. From low cost single contacts to fully integrated capped contacts. The unique feature of the 600 series is the fact that it was developed for Plated Through Hole (PTH) termination to the PCB. This addresses the rugged power type boards that have to handle larger wire gauges up to 12AWG and 15 Amps per contact of current. The PTH option provides robust PCB attachment and high current capabilities to replace older technology connectors or in most cases soldering stripped wires directly to the PCB.

APPLICATIONS

- Industrial pumps, motors and driver boards
- Solar and alternative energy products
- Commercial electrical equipment
- Reference Product Specification & application notes 201-01-141/142

FEATURES AND BENEFITS

- IDC contact provides a “gas tight” wire termination to the PCB to meet harsh industrial environments
- Simple, robust design offers a high performance solution to hand soldering large gauge wires to a PCB
- A single contact can handle up to 15A for high current applications with wire replacement up to 3 times
- The versatile family of IDC contact can accept 12-18AWG of stranded wires and can be tested for compliance with solid wires

ELECTRICAL

- Current Rating: 15A
- Voltage Rating: 600 VAC

ENVIRONMENTAL

- Operating Temperature: -40°C to +125°C

MECHANICAL

- Insulator Material: Nylon 46, UL94V0
- Contact Material: Phosphor Bronze
- Plating: Tin over Nickel
- Durability: Wires can be replaced up to 3 time

HOW TO ORDER

00	9177	00X
Prefix	Series	Number of Ways
Code	No of Ways	Details
001	1	Page 69

OXX			
Wire Insulation/Gauge Size			
Code	Style	Accepted Wire Gauge	Wire Insulation
691	Through Hole Mount	12AWG Solid or Stranded	Ø 4.25 Max
601	Through Hole Mount	14AWG Solid or Stranded	Ø 4.25 Max
612	Through Hole Mount	16AWG Solid or Stranded	Ø 3.50 Max
622	Through Hole Mount	18 AWG Solid or Stranded	Ø 3.50 Max

XX			
Color/Approval			
Code	Insulator Color	Cap Type	Description
00	Black - Special Order	Through Wire	Any Position Along Wire
09	Black - Special Order	Wire Stop	End of Wire - Includes Stop
10	White - Standard	Through Wire	Any Position Along Wire
19	White - Standard	Wire Stop	End of Wire - Includes Stop

6
Plating Option
6 = Pure Tin all Over



CAPPED THRU HOLE 12-18 AWG: 00-9177

1 Position - Through Wire

12 - 18 AWG 1 WAY IDC CONNECTOR WIRE THROUGH CAP

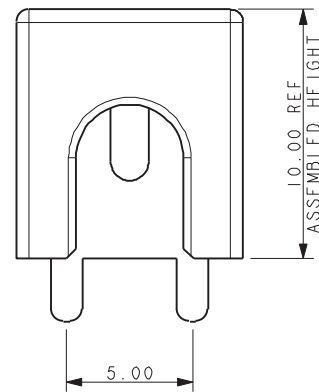
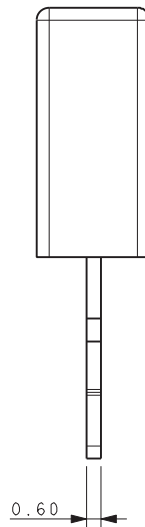
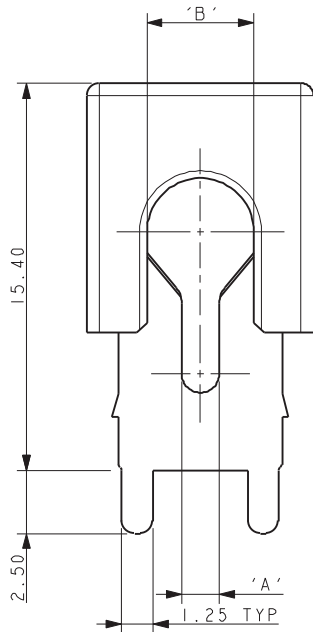
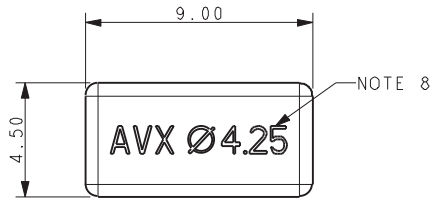

NOTES:

1. CONNECTOR FOR IDC WIRE TO BOARD CONNECTION, WIRE THROUGH CAP, CAN BE ASSEMBLED AT ANY POSITION ALONG A WIRE.
2. CONTACT MATERIAL: PHOSPHOR BRONZE. INSULATION MATERIAL: HIGH TEMP NYLON 46, UL94 V-0. COLOR REFER TO PAGE 68.
3. CONNECTOR DESIGNED TO ACCEPT BETWEEN 12 AND 18 AWG STRANDED WIRE.
4. ALL DIMENSIONS ± 0.20 UNLESS TOLERANCED.
5. FOR FULL PRODUCT SPECIFICATION ON STANDARD CONNECTORS REFER TO ELCO SPEC 201-01-141.
6. APPLICATION NOTES 201-01-142.
7. OUTLINE OF CAP. NO SPACE FOR COMPONENTS.
8. TEST TO INDICATE MAXIMUM INSULATION DIAMETER.

PACKING DETAILS



330mm DIAMETER REEL

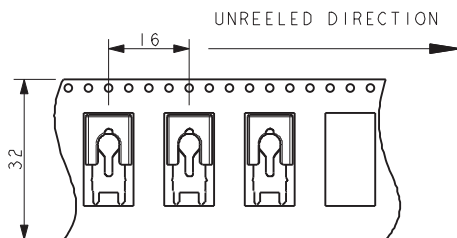

QUANTITY PER REEL 800

Code	Accepted Wire Gauge	A	Wire Insulation	B
691	12 AWG Solid or Stranded	1.50	Ø4.25 Max	4.25
601	14 AWG Solid or Stranded	1.10	Ø4.25 Max	4.25
612	16 AWG Solid or Stranded	0.82	Ø3.50 Max	3.50
622	18 AWG Solid or Stranded	0.72	Ø3.50 Max	3.50

SMT PCB LAYOUT PURE TIN PADS

