

REVISIONS

P	LTR	DESCRIPTION	DATE	DWN	APVD
	A	RELEASED	08MAY2017	R.Z	C.W

Transistor Sockets

8058 & 8060 Series

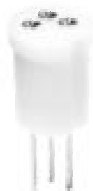

8060-1G11



8060-1G6

FEATURES:

The 8058/8060 family of teflon sockets, with beryllium copper contacts, offers many features which allow them to be utilized in the most severe applications. Low profile for close board spacing, closed sleeve for 100% prevention of solder and flux wicking. A choice of many terminal styles for greater packaging selection and ease of use. Many of these sockets meet or exceed MIL-S-83502/2 and MIL-S-83502/5.

- Two-piece socket terminal - four fingered inner contact and machined outer sleeve
- Low profile for tight space applications
- Sockets accept 0,41/.016 to 0,51/.020 diameter leads
- Printed circuit, solder pocket and turret style terminations available
- Closed entry-design no distortion or damage to contact with misaligned or oversized leads

MATERIAL SPECIFICATIONS:

Insulator .....Teflon  
 Sleeve .....Brass  
 Contact Plating .....Beryllium copper  
 Plating .....Contact gold, sleeve gold

**Note:** Before ordering, see Cross Reference in Section 15 for equivalent Tyco Electronics Part Number.

PERFORMANCE SPECIFICATIONS:

MECHANICAL

Vibration .....Passed MIL-STD -1344, Method 2005, 15 G's, 10 to 2,000 cycles  
 Mechanical Shock .....Passed MIL-STD -1344, Method 2004, 10 G's, 1 to 9,000 cycles  
 Durability .....50 Insertions and withdrawals, MIL-S-83502/ 1, Sec. 4.7.12  
 Insertion Force .....4.0 lb. max., .020 dia. +.0002 probe  
 Withdrawal Force .....14 Grams (1/2 oz.) min. .016 dia. +.0002 probe  
 Solderability .....MIL-STD- 202, Method 208

ELECTRICAL

Bulk Contact  
 Resistance .....20 Milliohms max. per MIL-S-83502/1  
 Current Rating .....3 Amp DC, contact rating  
 Operating Voltage .....500 VDC @ atmospheric pressure  
 Dielectric Withstanding  
 Voltage .....600 VAC per MIL-STD -1344 , Method 3001  
 Insulation Resistance .....2 x 10<sup>6</sup> Megohms, MIL-STD -1344, Method 3003  
 Capacitance .....2 pF Max., MIL-STD -202, Method 305

ENVIRONMENTAL

Operating Temperature .....-55°C to +125°C  
 Corrosive Atmosphere .....30 milliohms, ammonium polysulfide 10 ppm per MIL-S-83502/1 Sec. 4.7.17  
 Moisture Resistance .....30 Milliohms max., MIL-STD -202, Method 106  
 Thermal Shock .....MIL-STD -1344, Method 1003

THIS DRAWING IS UNPUBLISHED. ALL RIGHTS RESERVED. © COPYRIGHT - By -

DIMENSIONS: INCHES	DWN	08MAY2017	MATERIAL	-	FINISH	-
	CHK	08MAY2017				
TOLERANCES UNLESS OTHERWISE SPECIFIED:	APVD	08MAY2017				
0 PLC ± -	PRODUCT SPEC	-				
1 PLC ± -	APVD	08MAY2017	NAME			
2 PLC ± -	PRODUCT SPEC	-	8058&8060 SERIES			
3 PLC ± -	APVD	08MAY2017	TRANSISTOR SOCKETS			
4 PLC ± -	PRODUCT SPEC	-	SIZE	CAGE CODE	DRAWING NO	RESTRICTED TO
ANGLES ± -	APVD	08MAY2017	A4	00779	© 1437504-4	-
	PRODUCT SPEC	-	CUSTOMER DRAWING			
	APVD	08MAY2017	SCALE	SHEET	REV	
	PRODUCT SPEC	-	NTS	1 OF 4	A	

REVISIONS

P	LTR	DESCRIPTION	DATE	DWN	APVD
		SEE SHEET 1			

Transistor Sockets

8058 & 8060 Series

PART NUMBER / STANDARD CONFIGURATIONS

Part Number	Figure	No. of Contacts	Pin Circle	A	B	C	D	E*	F Max.	Terminal Style	Mounting Hole	Transistor Lead Length	Polarization Figure		
M8058-45G1	1	3	.200	.200	.265	.373	.410	.160	.406	Turret	B	.156/.218	N		
M8058-1G29	3	3	.200	.200	.270	.373	.410	.140	.351	Solder Pocket					
8058-1G29	3	3	.200	.200	.270	.373	.410	.140	.351	Solder Pocket					
8058-1G23	4	3	.200	.200	.270	.373	.410	.302	.544	Printed Circuit					
M8058-1G23	4	3	.200	.200	.270	.373	.410	.302	N/A	Printed Circuit	-	.125/.155	P		
8058-1G59	6	3	.200	.200	.165	N/A	.410	.125	N/A	Printed Circuit					
8058-38G6	6	3	.200	.200	.165	N/A	.410	.315	N/A	Printed Circuit	B	.156/.218	N		
8058-1G62	7	3	.200	.200	.270	.373	.410	.500	.703	Wirewrap					
M8058-45G2	1	4	.200	.200	.265	.373	.410	N/A	.406	Turret					
M8058-1G30	3	4	.200	.200	.265	.373	.410	.140	.377	Solder Pocket					
8058-1G30	3	4	.200	.200	.270	.373	.410	.140	.347	Solder Pocket	-	.125/.155	N		
M8058-1G24	4	4	.200	.200	.270	.373	.410	.347	.550	Printed Circuit					
8058-1G24	4	4	.200	.200	.270	.373	.410	.317	.550	Printed Circuit	B	.156/.218	N		
8058-1G63	7	4	.200	.200	.270	.373	.410	.500	.703	Wirewrap					
8058-1G58	2	5	.200	.200	.270	.373	.410	.094	.331	Turret					
8058-1G61	3	5	.200	.200	.270	.373	.410	.140	.336	Solder Pocket					
M8058-1G39	2	6 at 45°	.200	.200	.270	.373	.410	.094	.300	Turret	B	.156/.218	N		
8058-1G43	3	6 at 60°	.200	.200	.270	.373	.410	.140	.370	Solder Pocket					
M8058-1G18	3	6 at 45°	.200	.200	.270	.373	.410	.140	.370	Solder Pocket	-			.125/.155	P
8058-1G42	4	6 at 60°	.200	.200	.270	.373	.410	.317	.561	Printed Circuit					
M8058-1G33	4	6 at 45°	.200	.200	.270	.373	.410	.317	.561	Printed Circuit	B	.156/.218	N		
8058-1G48	6	6 at 60°	.200	.200	.165	N/A	.410	.125	N/A	Printed Circuit					
8058-1G52	6	6 at 45°	.200	.200	.165	N/A	.410	.125	N/A	Printed Circuit	-			.125/.155	P
M8058-1G37	2	8	.200	.200	.270	.373	.410	.094	.336	Turret					
M8058-1G19	3	8	.200	.200	.270	.373	.410	.140	.377	Solder Pocket	B	.156/.218	N		
8058-1G19	3	8	.200	.200	.270	.373	.410	.140	.377	Solder Pocket					
8058-1G57	3	8	.200	.200	.270	.373	.410	.140	.315	Solder Pocket	-			.125/.155	P
M8058-1G32	4	8	.200	.200	.270	.373	.410	.317	.550	Printed Circuit					
8058-1G32	4	8	.200	.200	.270	.373	.410	.317	.550	Printed Circuit	B	.156/.218	N		
8058-39G1	5	8	.200	.330	.375	.373	.410	.187	.505	Printed Circuit					
8058-39G3	5	8	.200	.380	.375	.373	.410	.150	.470	Printed Circuit	-			.125/.155	P
8058-39G5	5	8	.200	.380	.375	.373	.410	.150	.470	Printed Circuit					
8058-1G49	6	8	.200	.200	.165	N/A	.410	.125	N/A	Printed Circuit	B	.156/.218	N		
8058-1G47	2	8	.230	.230	.270	.373	.410	.094	.300	Turret					
8058-1G46	3	8	.230	.230	.270	.373	.410	.138	.346	Solder Pocket	-			.125/.165	P
8058-1G45	4	8	.230	.230	.270	.373	.410	.302	.534	Printed Circuit					
8058-39G4	5	8	.230	.380	.375	.373	.410	.155	.467	Printed Circuit	B	.156/.218	N		
8058-39G6	5	8	.230	.380	.375	.373	.410	.150	.467	Printed Circuit					
8058-1G50	6	8	.230	.230	.165	N/A	.410	.125	N/A	Printed Circuit	-			.125/.155	P
M8058-1G38	2	10	.230	.230	.270	.373	.410	.094	.331	Turret					
M8058-1G22	3	10	.230	.230	.270	.373	.410	.141	.377	Solder Pocket	B	.156/.218	N		
M8058-1G31	4	10	.230	.230	.270	.373	.410	.317	.561	Printed Circuit					
8058-24G1	5	10	.230	.380	.375	.373	.410	.187	.505	Printed Circuit	-			.125/.155	P
8058-1G34	6	10	.230	.230	.165	N/A	.410	.125	N/A	Printed Circuit					
M8058-1G91	6	10	.230	.230	.165	N/A	.410	.125	N/A	Printed Circuit	B	.156/.218	N		
8058-1G55	5	12	.250	.380	.375	.373	.410	.155	.467	Printed Circuit					
8058-1G51	6	12	.280	.280	.165	N/A	.410	.125	N/A	Printed Circuit	-			.125/.155	P

\* Dimension E ± .031 (0.79)

Note: Before ordering, see Cross Reference in Section 15 for equivalent Tyco Electronics Part Number.

THIS DRAWING IS UNPUBLISHED. ALL RIGHTS RESERVED. © COPYRIGHT - By -

DIMENSIONS: INCHES	DWN	RAMBO ZHANG	08MAY2017	MATERIAL	-	FINISH	-	
	CHK	SIMON LI	08MAY2017	 TE Connectivity				
TOLERANCES UNLESS OTHERWISE SPECIFIED:	APVD	COREL WANG	08MAY2017					NAME
	0 PLC ± -	PRODUCT SPEC	-	8058&8060 SERIES				
1 PLC ± -	APPLICATION SPEC	-	TRANSISTOR SOCKETS					
2 PLC ± -	WEIGHT	-	SIZE	CAGE CODE	DRAWING NO	RESTRICTED TO	-	
3 PLC ± -			A4	00779	①= 1437504-4			
4 PLC ± -			CUSTOMER DRAWING				SCALE	NTS
ANGLES ± -						SHEET	2 OF 4	
						REV	A	

REVISIONS

P	LTR	DESCRIPTION	DATE	DWN	APVD
		SEE SHEET 1			

**Transistor Sockets**

**8058 & 8060 Series**

**PART NUMBER / STANDARD CONFIGURATIONS**

Part Number	Figure	Number of Contacts	Pin Circle	A	B	C	D	E*	F Max.	Terminal Style	Mtg. Hole Figure	Transistor Lead Length	Polarization Figure
8060-1G5	3	3	.100	.100	.268	.227	.255	.146	.350	Solder Pocket	A	.156/.218	N
8060-1G17	3	3	.100	.100	.320	.227	.255	.084	.427				
8060-1G9	2	3	.100	.100	.268	.227	.255	.094	.372	Turret			
8060-1G11	4	3	.100	.100	.330	.227	.255	.240	.580	Printed Circuit	-	.125/.155	P
8060-1G7	5	3	.100	.200	.410	.227	.255	.170	.616				
8060-1G3	6	3	.100	.150	.195	N/A	.255	.103	N/A				
8060-1G13	6	3	.100	.100	.195	N/A	.255	.103	N/A	Solder Pocket	A	.156/.218	N
8060-1G6	3	4	.100	.100	.265	.227	.255	.146	.350				
8060-1G10	2	4	.100	.100	.265	.227	.255	.094	.310	Turret			
8060-1G12	4	4	.100	.100	.330	.227	.255	.240	.533	Printed Circuit	-	.125/.155	P
8060-1G8	5	4	.100	.200	.390	.227	.255	.187	.530				
8060-1G4	6	4	.100	.150	.195	N/A	.255	.103	N/A				
8060-1G22	6	4	.100	.100	.195	N/A	.255	.295	N/A				

\* Dimension E ± .031 (0,79)

All part number prefixed with (M) meet MIL-83502/1 or MIL-83502/6.

**Note:** Before ordering, see Cross Reference in Section 15 for equivalent Tyco Electronics Part Number.

THIS DRAWING IS UNPUBLISHED. ALL RIGHTS RESERVED. © COPYRIGHT - By -

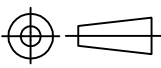
DIMENSIONS: INCHES	DWN RAMBO ZHANG	08MAY2017	MATERIAL	-	FINISH	-
	CHK SIMON LI	08MAY2017	 TE Connectivity			
TOLERANCES UNLESS OTHERWISE SPECIFIED:	APVD COREL WANG	08MAY2017				
0 PLC ± -	PRODUCT SPEC	-	NAME			8058&8060 SERIES
1 PLC ± -	-	-	8058&8060 SERIES			TRANSISTOR SOCKETS
2 PLC ± -	APPLICATION SPEC	-	SIZE	CAGE CODE	DRAWING NO	RESTRICTED TO
3 PLC ± -	-	-	A4	00779	©= 1437504-4	-
4 PLC ± -	WEIGHT	-	CUSTOMER DRAWING			SCALE
ANGLES ± -	-	-	NTS			SHEET
	CUSTOMER DRAWING			3 OF 4		REV
				A		

REVISIONS

P	LTR	DESCRIPTION	DATE	DWN	APVD
		SEE SHEET 1			

Transistor Sockets

8058 & 8060 Series

**Figure A**  
Recommended Chassis Cutout  
for all 8060 Series panel  
mount applications

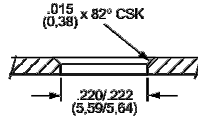

**Figure B**  
Recommended Chassis Cutout  
for all 8058 Series panel  
mount applications

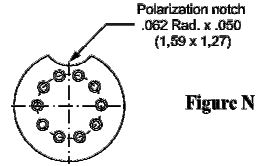
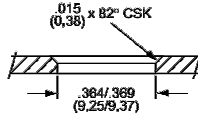

**Figure N**

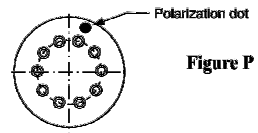

**Figure P**

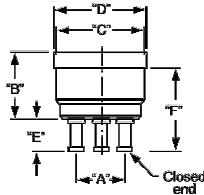

**Figure 1**

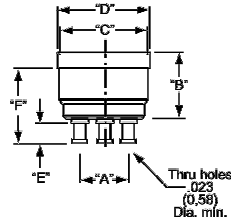

**Figure 2**

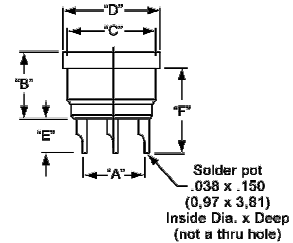

**Figure 3**

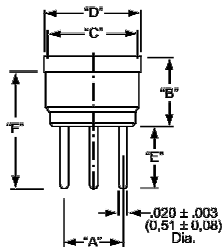

**Figure 4**

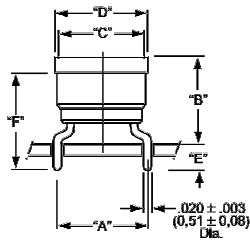

**Figure 5**

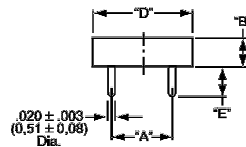

**Figure 6**

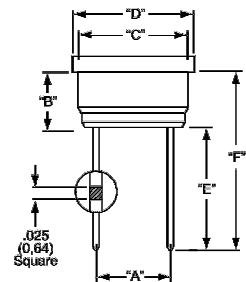

**Figure 7**

**Note:** Before ordering, see Cross Reference in Section 15 for equivalent Tyco Electronics Part Number.

THIS DRAWING IS UNPUBLISHED. ALL RIGHTS RESERVED. © COPYRIGHT - By -

DIMENSIONS: INCHES	DWN RAMBO ZHANG	08MAY2017	MATERIAL	-	FINISH	-	
	CHK SIMON LI	08MAY2017	<b>TE</b> TE Connectivity				
TOLERANCES UNLESS OTHERWISE SPECIFIED:	APVD COREL WANG	08MAY2017					
0 PLC ± -	PRODUCT SPEC	-	NAME 8058&8060 SERIES TRANSISTOR SOCKETS				
1 PLC ± -	APPLICATION SPEC	-					
2 PLC ± -	WEIGHT	-	SIZE	A4	CAGE CODE	00779	
3 PLC ± -	CUSTOMER DRAWING	-	DRAWING NO	C= 1437504-4		RESTRICTED TO	-
4 PLC ± -			SCALE	NTS	SHEET	4 OF 4	REV
ANGLES ± -							