

# AFBR-57F5MZ

16GFC SFP+ Digital Diagnostic SFP, 850 nm, 16G/8G/4G

Low Voltage (3.3 V) Fibre Channel Optical Transceiver



## Data Sheet



### Description

Avago Technologies' AFBR-57F5MZ optical transceiver supports high speed serial links over multi-mode optical fiber at signalling rates up to 14.025 Gb/s (the serial line rate of 16GFC). The product is compliant with Small Form Pluggable industry agreements SFP and SFP+ for mechanical and low speed electrical specifications. High speed electrical and optical specifications are compliant with ANSI Fibre Channel FC-PI-5.

The AFBR-57F5MZ is a multi-rate 850nm transceiver which ensures compliance with FC-PI-5 16GFC, 8GFC and 4GFC specifications. Per the requirements of 16GFC, internal clock and data recovery circuits (CDRs) are present on both electrical input and electrical output of this transceiver. These CDRs will lock at 14.025 Gb/s (16GFC) but must be bypassed for operation at 8.5 Gb/s (8GFC) and 4.25 Gb/s (4GFC), accomplished by using two Rate Select inputs to configure transmit and receive sides. Transmitter and receiver can operate at different data rates, as is often seen during Fibre Channel speed negotiation.

Digital diagnostic monitoring information (DMI) is present in the AFBR-57F5MZ per the requirements of SFF-8472, providing real time monitoring information of transceiver laser, receiver and environment conditions over a SFF-8431 2-wire serial interface.

### Related Products

- AFBR-57D7APZ: 850 nm SFP for 8G/4G/2G Fibre Channel
- AFCT-57D5ATPZ: 1310 nm SFP for 8G/4G/2G Fibre Channel
- AFCT-57D5ANPZ: 1310 nm SFP for 8G/4G/2G Fibre Channel
- AFBR-57R5APZ: 850 nm SFP for 4G/2G/1G Fibre Channel
- AFCT-57R5APZ: 1310 nm SFP for 4G/2G/1G Fibre Channel
- AFCT-57R5ATPZ: 1310 nm SFP for 4G/2G/1G Fibre Channel
- AFCT-57R5ANPZ: 1310 nm SFP for 4G/2G/1G Fibre Channel

### Features

- Compliant to RoHS directives
- 850 nm Vertical Cavity Surface Emitting Laser (VCSEL)
- Class 1 eye safe per IEC60825-1 and CDRH
- Wide temperature range (0 °C to 70 °C)
- LC duplex connector optical interface conforming to ANSI TIA/EIA604-10 (FOCIS 10A)
- Diagnostic features per SFF-8472 "Diagnostic Monitoring Interface for Optical Transceivers"
- Enhanced operational features including EWRAP, OWRAP and variable electrical EQ/emphasis settings
- Real time monitoring of:
  - Transmitter average optical power
  - Received average optical power
  - Laser bias current
  - Temperature
  - Supply Voltage
- SFP+ mechanical specifications per SFF-8432
- SFP+ compliant low speed interface
- Fibre Channel FC-PI-5 compliant high speed interface
  - 1600-SN-M6-S, 800-SN-M6-S, 400-SN-M6-I
  - 1600-SN-M5-S, 800-SN-M5-S, 400-SN-M5-I
  - 1600-SN-M5E-I, 800-SN-M5E-I, 400-SN-M5E-I
  - 1600-SN-M5F-I, 800-SN-M5F-I, 400-SN-M5F-I
- Fibre Channel FC-PI-5 compliant optical link distances

### Applications

- Fibre Channel switches (director, stand alone, blade)
- Fibre Channel Host Bus Adapters
- Fibre Channel RAID controllers
- Fibre Channel tape drive
- Port side connections
- Inter-switch or inter-chassis aggregated links

## Installation

The AFBR-57F5MZ can be installed in any SFF-8074i compliant Small Form Pluggable (SFP) port regardless of host equipment operating status. The AFBR-57F5MZ is hot-pluggable, allowing the module to be installed while the host system is operating and on-line. Upon insertion, the transceiver housing makes initial contact with the host board SFP cage, mitigating potential damage due to Electro-Static Discharge (ESD).

## Digital Diagnostic Interface and Serial Identification

The 2-wire serial interface is based on ATMEL AT24C01A series EEPROM protocol and signaling detail. Conventional EEPROM memory, bytes 0-255 at memory address 0xA0, is organized in compliance with SFF-8074i. New digital diagnostic information, bytes 0-255 at memory address 0xA2, is compliant to SFF-8472. The new diagnostic information provides the opportunity for Predictive Failure Identification, Compliance Prediction, Fault Isolation and Component Monitoring.

## Predictive Failure Identification

The AFBR-57F5MZ predictive failure feature allows a host to identify potential link problems before system performance is impacted. Prior identification of link problems enables a host to service an application via “fail over” to a redundant link or replace a suspect device, maintaining system uptime in the process. For applications where ultra-high system uptime is required, a digital SFP provides a means to monitor two real-time laser metrics associated with observing laser degradation and predicting failure: average laser bias current (Tx\_Bias) and average laser optical power (Tx\_Power).

## Compliance Prediction

Compliance prediction is the ability to determine if an optical transceiver is operating within its operating and environmental requirements. AFBR-57F5MZ devices provide real-time access to transceiver internal supply voltage and temperature, allowing a host to identify potential component compliance issues. Received optical power is also available to assess compliance of a cable plant and remote transmitter. When operating out of requirements, the link cannot guarantee error free transmission.

## Fault Isolation

The fault isolation feature allows a host to quickly pinpoint the location of a link failure, minimizing downtime. For optical links, the ability to identify a fault at a local device, remote device or cable plant is crucial to speeding service of an installation. AFBR-57F5MZ real-time monitors of Tx\_Bias, Tx\_Power, Vcc, Temperature and Rx\_Power can be used to assess local transceiver current operating conditions. In addition, status flags Tx\_Disable and Rx Loss of Signal (LOS) are mirrored in memory and available via the two-wire serial interface.

## Component Monitoring

Component evaluation is a more casual use of the AFBR-57F5MZ real-time monitors of Tx\_Bias, Tx\_Power, Vcc, Temperature and Rx\_Power. Potential uses are as debugging aids for system installation and design, and transceiver parametric evaluation for factory or field qualification. For example, temperature per module can be observed in high density applications to facilitate thermal evaluation of blades, PCI cards and systems.

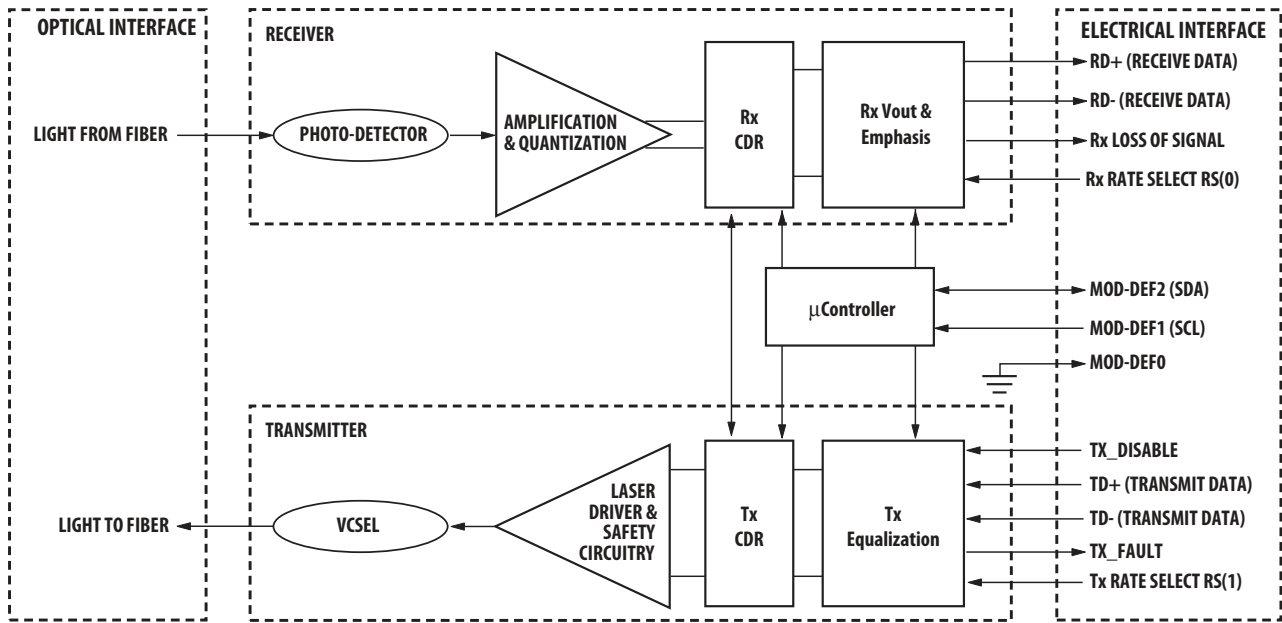

Figure 1. Transceiver functional diagram.

## Transmitter Section

The transmitter section includes a Transmitter Optical SubAssembly (TOSA), laser driver circuit, Clock and Data Recovery circuit (CDR) and an electrical input stage with variable equalization controls and electrical eye measurement capability. The TOSA contains a 850 nm Vertical Cavity Surface Emitting Laser (VCSEL) light source with integral light monitoring function and imaging optics to assure efficient optical coupling to the LC connector interface. The TOSA is driven by a laser driver IC, which uses the differential output from an integral Tx CDR stage to modulate and regulate VCSEL optical power. As mandated by FC-PI-5, the integral CDR cleans up any incoming jitter accumulated from the host ASIC, PCB traces and SFP electrical connector. Between the SFP electrical connector and Tx CDR is a variable, I<sup>2</sup>C-bus controlled, equalization circuit to optimize SFP performance with non-ideal incoming electrical waveforms. Note the Tx CDR is engaged only with Tx\_RATE=high (16GFC) and bypassed with Tx\_RATE=low (8G/4G).

### Transmit Disable (Tx\_Disable)

The AFBR-57F5MZ accepts a TTL and CMOS compatible transmit disable control signal input (pin 3) which shuts down the transmitter optical output. A high signal implements this function while a low signal allows normal transceiver operation. In the event of a fault (e.g. eye safety circuit activated), cycling this control signal resets the module as depicted in Figure 4. An internal pull up resistor disables the transceiver transmitter until the host pulls the input low. Host systems should allow a 10 ms interval be-

tween successive assertions of this control signal. Tx\_Disable can also be asserted via the two-wire serial interface (address A2h, byte 110, bit 6) and monitored (address A2h, byte 110, bit 7).

The contents of A2h, byte 110, bit 6 are logic OR'd with hardware Tx\_Disable (pin 3) to control transmitter operation.

### Transmit Fault (Tx\_Fault)

A catastrophic laser fault will activate the transmitter signal, TX\_FAULT, and disable the laser. This signal is an open collector output (pull-up required on the host board). A low signal indicates normal laser operation and a high signal indicates a fault. The TX\_FAULT will be latched high when a laser fault occurs and is cleared by toggling the TX\_DISABLE input or power cycling the transceiver. The transmitter fault condition can also be monitored via the two-wire serial interface (address A2, byte 110, bit 2).

### Eye Safety Circuit

The AFBR-57F5MZ provides Class 1 (single fault tolerant) eye safety by design and has been tested for compliance with the requirements listed in Table 1. The eye safety circuit continuously monitors the optical output power level and will disable the transmitter upon detecting an unsafe condition beyond the scope of Class 1 certification. Such unsafe conditions can be due to inputs from the host board (Vcc fluctuation, unbalanced code) or a fault within the transceiver.

## Receiver Section

The receiver section includes a Receiver Optical SubAssembly (ROSA), pre-amplification and post-amplification circuit, Clock and Data Recovery Circuit and an electrical output stage with variable emphasis controls. The ROSA, containing a high speed PIN detector, pre-amplifier and imaging optics efficiently couple light from the LC connector interface and perform an optical to electrical conversion. The resulting differential electrical signal passes through a post amplification circuit and into a Clock and Data Recovery circuit (CDR) for cleaning up accumulated jitter. The resulting signal is passed to a high speed output line driver stage with variable, I<sup>2</sup>C-bus controlled, emphasis settings allowing the host to optimize signal characteristics between the SFP and host ASIC. Note the Rx CDR is engaged only with Rx\_RATE=high (16GFC) and bypassed with Rx\_RATE=low (8G/4G).

## Receiver Loss of Signal (Rx\_LOS)

The post-amplification IC also includes transition detection circuitry which monitors the ac level of incoming optical signals and provides a TTL/CMOS compatible status signal to the host (pin 8). An adequate optical input results in a low Rx\_LOS output while a high Rx\_LOS output indicates an unusable optical input. The Rx\_LOS thresholds are factory set so that a high output indicates a definite optical fault has occurred. Rx\_LOS can also be monitored via the two-wire serial interface (address A2h, byte 110, bit 1).

## Functional Data I/O

The AFBR-57F5MZ interfaces with the host circuit board through twenty I/O pins (SFP electrical connector) identified by function in Table 2. The board layout for this interface is depicted in Figure 6.

The AFBR-57F5MZ high speed transmit and receive interfaces require SFP MSA compliant signal lines on the host board. To simplify board requirements, biasing resistors and ac coupling capacitors are incorporated into the SFP transceiver module (per SFF-8074i) and hence are not required on the host board. The Tx\_Disable, Tx\_Fault, and Rx\_LOS lines require TTL lines on the host board (per SFF-8074i) if used. If an application chooses not to take advantage of the functionality of these pins, care must be taken to ground Tx\_Disable (for normal operation).

Figure 2 depicts the recommended interface circuit to link the AFBR-57F5MZ to supporting physical layer ICs. Timing for MSA compliant control signals implemented in the transceiver are listed in Figure 4.

## Application Support

An Evaluation Kit and Reference Designs are available to assist in evaluation of the AFBR-57F5MZ. Please contact your local Field Sales representative for availability and ordering details.

## Caution

There are no user serviceable parts nor maintenance requirements for the AFBR-57F5MZ. All mechanical adjustments are made at the factory prior to shipment. Tampering with, modifying, misusing or improperly handling the AFBR-57F5MZ will void the product warranty. It may also result in improper operation and possibly overstress the laser source. Performance degradation or device failure may result. Connection of the AFBR-57F5MZ to a light source not compliant with ANSI FC-PI specifications, operating above maximum operating conditions or in a manner inconsistent with it's design and function may result in exposure to hazardous light radiation and may constitute an act of modifying or manufacturing a laser product. Persons performing such an act are required by law to re-certify and re-identify the laser product under the provisions of U.S. 21 CFR (Subchapter J) and TUV.

## Ordering Information

Please contact your local field sales engineer or one of Avago Technologies franchised distributors for ordering information. For technical information, please visit Avago Technologies' WEB page at [www.avagotech.com](http://www.avagotech.com) or contact Avago Technologies Semiconductor Products Customer Response Center at 1-800-235-0312. For information related to SFF Committee documentation visit [www.sffcommittee.org](http://www.sffcommittee.org).

## Regulatory Compliance

The AFBR-57F5MZ complies with all applicable laws and regulations as detailed in Table 1. Certification level is dependent on the overall configuration of the host equipment. The transceiver performance is offered as a figure of merit to assist the designer.

## Electrostatic Discharge (ESD)

The AFBR-57F5MZ is compatible with ESD levels found in typical manufacturing and operating environments as described in Table 1. In the normal handling and operation of optical transceivers, ESD is of concern in two circumstances.

The first case is during handling of the transceiver prior to insertion into an SFP compliant cage. To protect the device, it's important to use normal ESD handling precautions. These include use of grounded wrist straps, workbenches and floor wherever a transceiver is handled.

The second case to consider is static discharges to the exterior of the host equipment chassis after installation. If the optical interface is exposed to the exterior of host equipment cabinet, the transceiver may be subject to system level ESD requirements.

## Electromagnetic Interference (EMI)

Equipment incorporating gigabit transceivers is typically subject to regulation by the FCC in the United States, CENELEC EN55022 (CISPR 22) in Europe and VCCI in Japan. The AFBR-57F5MZ's compliance to these standards is detailed in Table 1. The metal housing and shielded design of the AFBR-57F5MZ minimizes the EMI challenge facing the equipment designer.

### EMI Immunity (Susceptibility)

Due to its shielded design, the EMI immunity of the AFBR-57F5MZ exceeds typical industry standards.

### Flammability

The AFBR-57F5MZ optical transceiver is made of metal and high strength, heat resistant, chemical resistant and UL 94V-0 flame retardant plastic.

**Table 1. Regulatory Compliance**

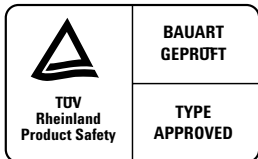
Feature	Test Method	Performance
Electrostatic Discharge (ESD) to the Electrical Pins	MIL-STD-883C Method 3015.4	Class 1 (> 2000 Volts)
Electrostatic Discharge (ESD) to the Duplex LC Receptacle	Variation of IEC 61000-4-2	Typically, no damage occurs with 25 kV when the duplex LC connector receptacle is contacted by a Human Body Model probe.
	GR1089	10 contacts of 8 kV on the electrical faceplate with device inserted into a panel.
Electrostatic Discharge (ESD) to the Optical Connector	Variation of IEC 801-2	Air discharge of 15 kV (min.) contact to connector without damage.
Electromagnetic Interference (EMI)	FCC Class B CENELEC EN55022 Class B (CISPR 22A) VCCI Class 1	System margins are dependent on customer board and chassis design.
Immunity	Variation of IEC 61000-4-3	Typically shows no measurable effect from a 10 V/m field swept from 10 MHz to 1 GHz.
Laser Eye Safety and Equipment Type Testing	US FDA CDRH AEL Class 1 US21 CFR, Subchapter J per Paragraphs 1002.10 and 1002.12  (IEC) EN60825-1: 1994 + A11 + A2 (IEC) EN60825-2: 1994 + A1 (IEC) EN60950: 1992 + A1 + A2 + A3 + A4 + A11	CDRH certification 9720151-111 TUV file 72102056
		
Component Recognition	Underwriters Laboratories and Canadian Standards Association Joint Component Recognition for Information Technology Equipment including Electrical Business Equipment	UL file 8543036783
RoHS Compliance		Less than 1000 ppm of cadmium, lead, mercury, hexavalent chromium, polybrominated biphenyls, and polybrominated biphenyl ethers.

## Special Operation Functions:

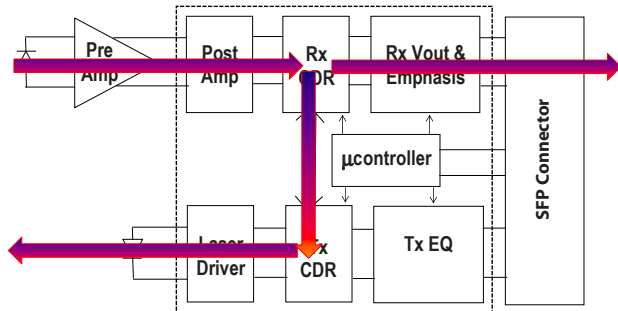

Figure 2a. OWRAP Functionality (I<sup>2</sup>C-bus controlled)

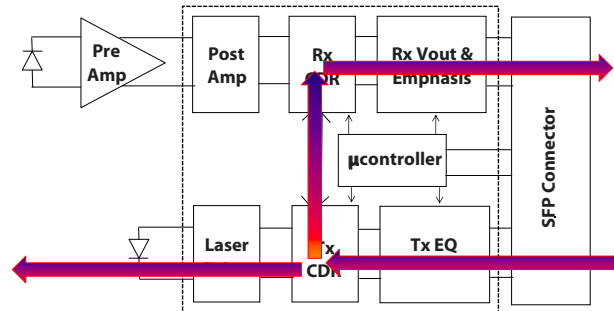

Figure 2b. EWRAP Functionality (I<sup>2</sup>C-bus controlled)

Electrical and optical high speed data “wrap” functions are enabled to assist with local host or remote diagnostic and optimization sequences. Optical data wrap (OWRAP) takes a received optical signal through a CDR jitter cleanup and retransmits it optically out. Electrical data wrap (EWRAP) takes an incoming electrical signal through a CDR jitter cleanup and retransmits it electrically out. An optional pass-through function is available to transmit outbound the wrapped information, controlled through I<sup>2</sup>C-bus commands.

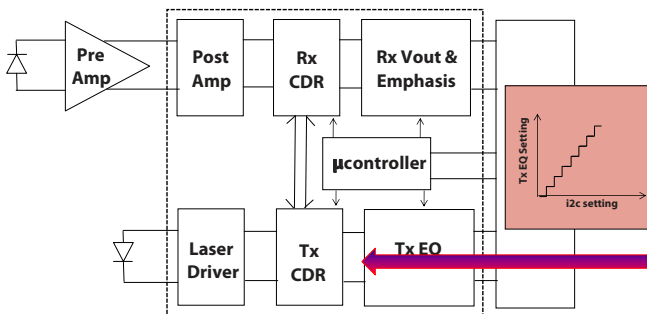

Figure 2c. SFP Tx Variable Input Electrical EQ (I<sup>2</sup>C-bus controlled)

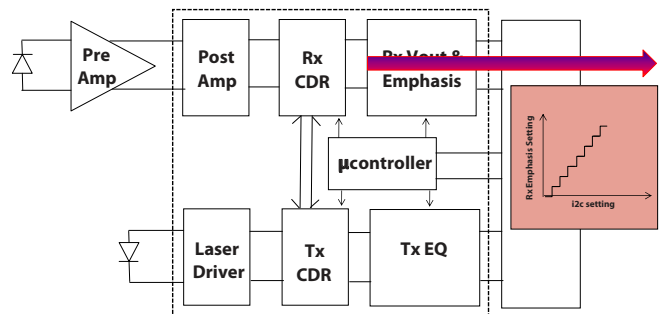

Figure 2d. SFP Rx Variable Output Electrical Emphasis (I<sup>2</sup>C-bus controlled)

The electrical SFP input stage (TD +/-) has been enhanced with features to allow host control and optimization of the transceiver’s input equalization settings. The host can then select, in situ, the most appropriate SFP setting for a given interconnect scenario.

The SFP electrical output stage (RD +/-) has been enhanced with variable output emphasis features to allow host control and optimization of the receiver’s output settings. The host can then select, in situ, the most appropriate SFP setting for a given interconnect scenario. To assist with optimizing the receiver output setting, the user can have data transmitted by the SFP to a host ASIC by using EWRAP to loop back host generated traffic or can use a remotely generated optical signal as a data source for SFP and interconnect training.

**Table 2. Rate Select Function**

Function	State	Explanation
Rx Rate Select RS(0)	High	Receive Rate Select HIGH engages the internal Rx CDR. The CDR will look for valid 16GFC traffic and lock within 500us when found. Due to differences in coding, this CDR will not be able to lock on valid 8GFC or 4GFC traffic.
	Low	Receive Rate Select LOW bypasses the internal Rx CDR. This is intended for use only with 8GFC and 4GFC traffic. When set low, the SFP behaves like a legacy SFP.
Tx Rate Select RS(1)	High	Transmit Rate Select HIGH engages the internal Tx CDR. The CDR will look for valid 16GFC traffic and lock within 500us when found. Due to differences in coding, this CDR will not be able to lock on valid 8GFC or 4GFC traffic.
	Low	Transmit Rate Select LOW bypasses the internal Tx CDR. This is intended for use only with 8GFC and 4GFC traffic. When set low, the SFP behaves like a legacy SFP.

Note: During Fibre Channel Link Speed Negotiation sequences, the host will control Tx Rate and Rx Rate inputs separately to accomplish link initialization. Once speed negotiation is complete, it is expected both Tx Rate and Rx Rate will be placed in the same state by the host.

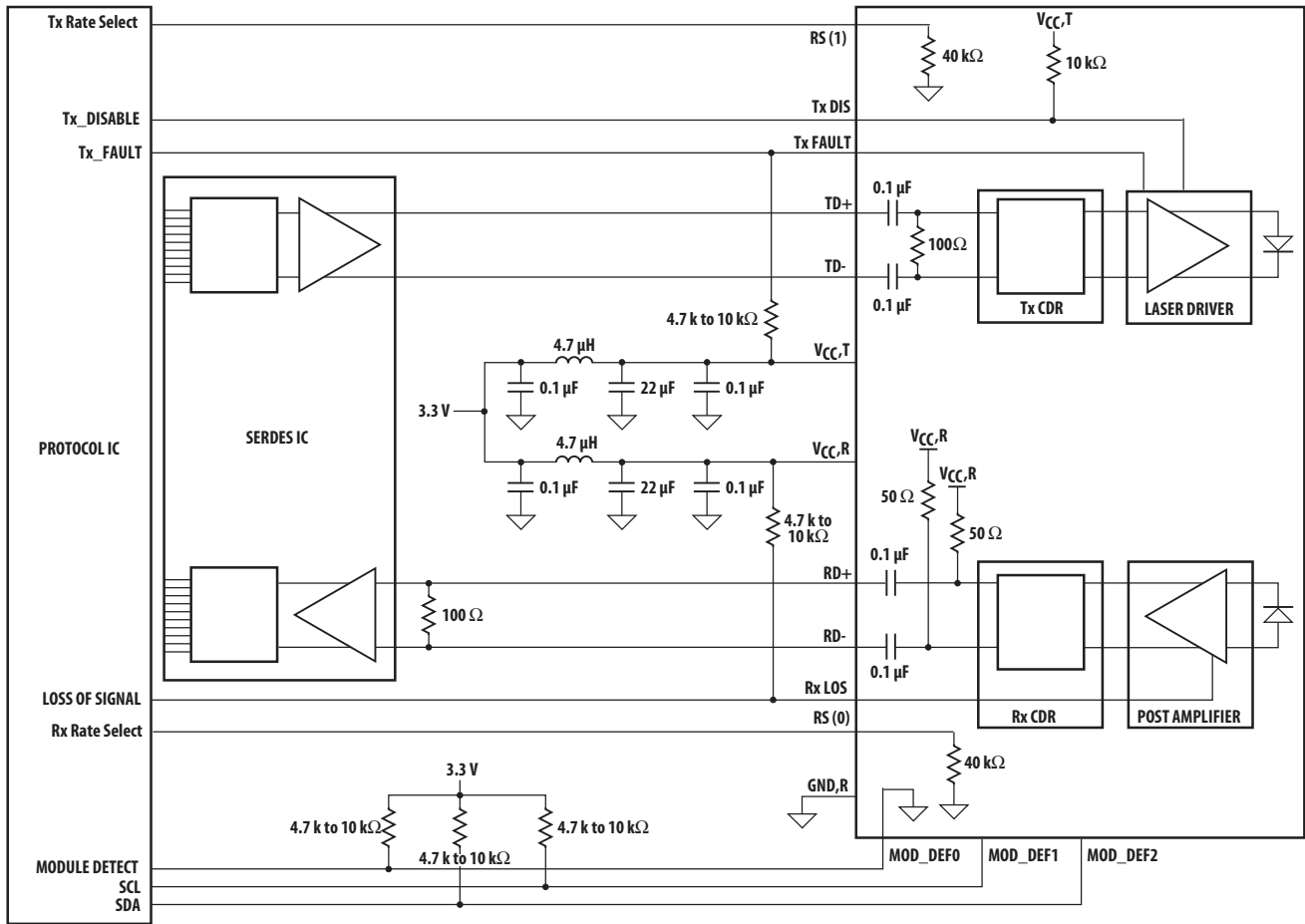
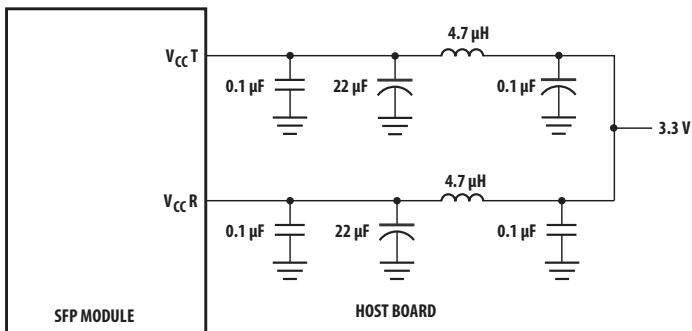

Figure 3. Typical application configuration



NOTE: INDUCTORS MUST HAVE LESS THAN 1Ω SERIES RESISTANCE TO LIMIT VOLTAGE DROP TO THE SFP MODULE.

Figure 4. Recommended power supply filter



**Table 3. Pin Description**

Pin	Name	Function/Description	Notes
1	VeeT	Transmitter Ground	
2	TX_FAULT	Transmitter Fault Indication – High indicates a fault condition	Note 1
3	TX_DISABLE	Transmitter Disable – Module electrical input disables on high or open	Note 2
4	MOD-DEF2	Module Definition 2 – Two wire serial ID interface data line (SDA)	Note 3
5	MOD-DEF1	Module Definition 1 – Two wire serial ID interface clock line (SCL)	Note 3
6	MOD-DEF0	Module Definition 0 – Grounded in module (module present indicator)	Note 3
7	Rx Rate Select RS(0)	Receiver rate select. Logic High = 14.025 Gb/s, Logic Low = 8.5 Gb/s and 4.25 Gb/s	Note 8
8	RX_LOS	Loss of Signal – High indicates loss of received optical signal	Note 4
9	Tx Rate Select RS(1)	Transmitter rate select. Logic High = 14.025 Gb/s, Logic Low = 8.5 Gb/s and 4.25 Gb/s	Note 8
10	VeeR	Receiver Ground	
11	VeeR	Receiver Ground	
12	RD-	Inverse Received Data Out	Note 5
13	RD+	Received Data Out	Note 5
14	VeeR	Receiver Ground	
15	VccR	Receiver Power + 3.3 V	Note 6
16	VccT	Transmitter Power + 3.3 V	Note 6
17	VeeT	Transmitter Ground	
18	TD+	Transmitter Data In	Note 7
19	TD-	Inverse Transmitter Data In	Note 7
20	VeeT	Transmitter Ground	

**Notes:**

- TX\_FAULT is an open collector/drain output, which must be pulled up with a 4.7 k – 10 kΩ resistor on the host board. When high, this output indicates a laser fault of some kind. Low indicates normal operation. In the low state, the output will be pulled to < 0.8V.
- TX\_DISABLE is an input that is used to shut down the transmitter optical output. It is internally pulled up (within the transceiver) with a 6.8 kΩ resistor.
 

Low (0 – 0.8V):	Transmitter on
Between (0.8V and 2.0V):	Undefined
High (2.0 – Vcc max) or OPEN:	Transmitter Disabled
- The signals Mod-Def 0, 1, 2 designate the two wire serial interface pins. They must be pulled up with a 4.7 k – 10 kΩ resistor on the host board.
  - Mod-Def 0 is grounded by the module to indicate the module is present
  - Mod-Def 1 is serial clock line (SCL) of two wire serial interface
  - Mod-Def 2 is serial data line (SDA) of two wire serial interface
- RX\_LOS (Rx Loss of Signal) is an open collector/drain output that must be pulled up with a 4.7 k – 10 kΩ resistor on the host board. When high, this output indicates the received optical power is below the worst case receiver sensitivity (as defined by the standard in use). Low indicates normal operation. In the low state, the output will be pulled to < 0.8V.
- RD-/+ designate the differential receiver outputs. They are AC coupled 100Ω differential lines which should be terminated with 100Ω differential at the host SERDES input. AC coupling is done inside the transceiver and is not required on the host board. The voltage swing on these lines will be between 370 and 850 mV differential (185 – 425 mV single ended) when properly terminated.
- VccR and VccT are the receiver and transmitter power supplies. They are defined at the SFP connector pin. The maximum supply current is 300 mA and the associated in-rush current will typically be no more than 30 mA above steady state after 2 microseconds.
- TD-/+ designate the differential transmitter inputs. They are AC coupled differential lines with 100 Ω differential termination inside the module. The AC coupling is done inside the module and is not required on the host board. The inputs will accept differential swings of 180 – 1200 mV (90 – 600 mV single ended)
- Rate\_Select is an input that is used to control transmit and receive high speed parametric optimization. It is internally pulled down (within the transceiver) with a 40kΩ resistor.
 

Low (0 - 0.8V) or Open:	Rate is set to 8.5Gb/s and below optimization. The CDR is bypassed.
Between (0.8V and 2.0V)	Undefined
High (2.0 - Vcc max):	Rate is set to 14.025Gb/s optimization. The CDR is engaged.



**Table 4. Absolute Maximum Ratings**

Parameter	Symbol	Minimum	Maximum	Unit	Notes
Storage Temperature	T <sub>S</sub>	-40	85	C	Note 1, 2
Case Operating Temperature	T <sub>C</sub>	-40	85	C	Note 1, 2
Relative Humidity	RH	5	95	%	Note 1
Supply Voltage	V <sub>CC</sub> T, R	-0.5	3.8	V	Note 1, 2, 3
Low Speed Input Voltage	V <sub>IN</sub>	-0.5	V <sub>CC</sub> +0.5	V	Note 1

**Notes:**

1. Absolute Maximum Ratings are those values beyond which damage to the device may occur if these limits are exceeded for other than a short period of time. See Reliability Data Sheet for specific reliability performance.
2. Between Absolute Maximum Ratings and the Recommended Operating Conditions functional performance is not intended, device reliability is not implied, and damage to the device may occur over an extended period of time.
3. The module supply voltages, V<sub>CC</sub>T and V<sub>CC</sub>R must not differ by more than 0.5 V or damage to the device may occur.

**Table 5. Recommended Operating Conditions**

Parameter	Symbol	Minimum	Maximum	Unit	Notes
Case Operating Temperature	T <sub>C</sub>	0	70	°C	Note 1, 2
Supply Voltage	V <sub>CC</sub> T, R	3.135	3.465	V	Note 2
Data Rate		4.25	14.025	Gb/s	Note 2

**Notes:**

1. The Ambient Operating Temperature limitations are based on the Case Operating Temperature limitations and are subject to the host system thermal design.
2. Recommended Operating Conditions are those values for which functional performance and device reliability is implied.

**Table 6. Transceiver Electrical Characteristics**(T<sub>C</sub> = 0 °C to 70 °C, V<sub>CC</sub>T, V<sub>CC</sub>R = 3.3V ± 5%)

Parameter	Symbol	Minimum	Typical	Maximum	Unit	Notes
<b>AC Electrical Characteristics</b>						
Power Supply Noise Rejection (peak-peak)	PSNR	100			mV	Note 1
<b>DC Electrical Characteristics</b>						
Module Supply Current	I <sub>CC</sub>			300	mA	
Low Speed Outputs:	V <sub>OH</sub>	2.0		V <sub>CC</sub> T,R+0.3	V	Note 2
Transmit Fault (TX_FAULT), Loss of Signal (RX_LOS), MOD-DEF 2	V <sub>OL</sub>			0.8	V	
Low Speed Inputs:	V <sub>IH</sub>	2.0		V <sub>CC</sub>	V	Note 3
Transmit Disable (TX_DIS), MOD-DEF 1, MOD-DEF2, RS(0), RS(1)	V <sub>IL</sub>	0		0.8	V	

**Notes:**

1. Filter per SFP specification is required on host board to remove 10 Hz to 2 MHz content.
2. Pulled up externally with a 4.7 k – 10 kΩ resistor on the host board to 3.3 V.
3. Mod-Def1 and Mod-Def2 must be pulled up externally with a 4.7 k – 10 kΩ resistor on the host board to 3.3 V.

**Table 7. Transmitter and Receiver Electrical Characteristics**(T<sub>C</sub> = 0 °C to 70 °C, V<sub>CC</sub>T, V<sub>CC</sub>R = 3.3V ± 5%)

Parameter	Symbol	Min	Typ	Max	Unit	Notes
High Speed Data Input Transmitter Differential Input Voltage (TD+/-)	V <sub>I</sub>	180		1200	mV	Note 1
High Speed Data Output Receiver Differential Output Voltage (RD+/-)	V <sub>O</sub>	370		850	mV	Note 2
Receiver Total Jitter (14.025 Gb/s)	TJ			0.36	UI	Note 3, Rx_Rate = high
Receiver Total Jitter (8.5 Gb/s)	TJ			0.71	UI	Note 4, Rx_Rate = low
Receiver Contributed Total Jitter (4.25 Gb/s)	TJ			0.26	UI	Note 4, Rx_Rate = low
Receiver Deterministic Jitter (14.025 Gb/s)	DJ			0.22	UI	Note 3, Rx_Rate = high
Receiver Deterministic Jitter (8.5 Gb/s)	DJ			0.42	UI	Note 4, Rx_Rate = low
Receiver Contributed Deterministic Jitter (4.25 Gb/s)	DJ			0.10	UI	Note 4, Rx_Rate = low
Receiver Data Dependent Pulse Width Shrinkage (14.025 Gb/s)	DDPWS			0.14	UI	Note 3, Rx_Rate = high
Receiver Data Dependent Pulse Width Shrinkage (8.5 Gb/s)	DDPWS			0.36	UI	Note 4, Rx_Rate = low

Notes:

- Internally ac coupled and terminated (100Ω differential).
- Internally ac coupled but requires an external load termination (100Ω differential).
- CDR is engaged with Rx\_Rate = high. Received output jitter for 14.025 Gb/s.
- CDR is not engaged with Rx\_Rate = low (ie. Bypassed). Receiver output jitter for 8.5 Gb/s and 4.25Gb/s.

**Table 8. Transmitter Optical Characteristics**(T<sub>C</sub> = 0 °C to 70 °C, V<sub>CC</sub>T, V<sub>CC</sub>R = 3.3V ± 5%)

Parameter	Symbol	Min	Typ	Max	Unit	Notes
Modulated Optical Output Power (OMA) (Peak to Peak) 14.025Gb/s	Tx,OMA	331			μW	
Modulated Optical Output Power (OMA) (Peak to Peak) 8.5Gb/s	Tx,OMA	302			μW	
Modulated Optical Output Power (OMA) (Peak to Peak) 4.25Gb/s	Tx,OMA	247			μW	
Average Optical Output Power	P <sub>out</sub>	-7.8			dBm	Note 1
Center Wavelength	λ <sub>c</sub>	840		860	nm	
Spectral Width – rms	θ <sub>rms</sub>			0.59	nm	
Optical Rise Time (20%-80%)	tr, tf		30		ps	
RIN12 (OMA)	RIN			-128	dB/Hz	
Vertical Eye Closure Penalty, 14.025Gb/s	VECP			2.56	dB	Note 2
Transmitter Waveform Distortion Penalty, 8.5Gb/s	TWDP			4.3	dB	Note 3
Transmitter Uncorrelated Jitter, 14.025Gb/s	UJ			0.03	UI	Note 2
Transmitter Uncorrelated Jitter, 8.5Gb/s	UJ			0.03	UI	Note 3
Transmitter Contributed Jitter, 4.25Gb/s	TJ			0.25	UI	Note 3
Pout Tx_DISABLE Asserted	P <sub>off</sub>			-35	dBm	

Notes:

- Max P<sub>out</sub> is the lesser of Class 1 safety limits (CDRH and EN 60825) or received power, max.
- CDR is engaged with Tx\_Rate = high. Transmitter output jitter for 14.025 Gb/s.
- CDR is not engaged with Tx\_Rate = low (ie. Bypassed). Transmitter output jitter for 8.5 Gb/s and 4.25 Gb/s.

**Table 9. Receiver Optical and Electrical Characteristics**(T<sub>C</sub> = 0 °C to 70 °C, V<sub>CC</sub>T, V<sub>CC</sub>R = 3.3V ± 5%)

Parameter	Symbol	Min	Typ	Max	Unit	Notes
Optical Input Power	P <sub>IN</sub>			0	dBm,avg	
Input Optical Modulation Amplitude, 14.025Gb/s (Peak to Peak) [Unstressed Sensitivity]	OMA	89			μW,OMA	Note 1
Input Optical Modulation Amplitude, 8.5Gb/s (Peak to Peak) [Unstressed Sensitivity]	OMA	76			μW,OMA	Note 1
Input Optical Modulation Amplitude, 4.25Gb/s (Peak to Peak) [Unstressed Sensitivity]	OMA	61			μW,OMA	Note 1
Stressed Receiver Sensitivity (OMA) 14.025Gb/s		170			μW,OMA	Note 2, all fiber types
Stressed Receiver Sensitivity (OMA) 8.5Gb/s		151			μW,OMA	Note 3, all fiber types
Stressed Receiver Sensitivity (OMA) 4.25Gb/s		148 138 126			μW,OMA	OM1 62.5μm fiber OM2 50μm fiber, Note 4 OM3 50μm fiber
Return Loss		12			dB	
Loss of Signal – Assert	Pa	-30			dBm,avg	
Loss of Signal – De-asserted	PD			-14	dBm,avg	
Loss of Signal – Hysteresis	PA – PD	0.5			dB	

Notes:

1. Input Optical Modulation Amplitude (commonly known as sensitivity) requires a valid Fibre Channel encoded input.
2. 14.025 Gb/s stressed received vertical eye closure penalty (ISI) min is 2.5 dB for all fiber types.
3. 8.5 Gb/s stressed received vertical eye closure penalty (ISI) min is 3.1 dB for all fiber types.
4. 4.25 Gb/s stressed received vertical eye closure penalty (ISI) min is 0.75 dB for OM3 fiber, 1.67 dB for OM2 fiber and 2.14 dB for OM1 fiber..

**Table 10. Transceiver SOFT DIAGNOSTIC Timing Characteristics**(T<sub>C</sub> = 0 °C to 70 °C, V<sub>CC</sub>T, V<sub>CC</sub>R = 3.3V ± 5%)

Parameter	Symbol	Minimum	Maximum	Unit	Notes
Hardware TX_DISABLE Assert Time	t <sub>off</sub>		10	µs	Note 1
Hardware TX_DISABLE Negate Time	t <sub>on</sub>		1	ms	Note 2
Time to initialize, including reset of TX_FAULT	t <sub>init</sub>		300	ms	Note 3
Hardware TX_FAULT Assert Time	t <sub>fault</sub>		100	µs	Note 4
Hardware TX_DISABLE to Reset	t <sub>reset</sub>	10		µs	Note 5
Hardware RX_LOS Deassert Time	t <sub>loss_on</sub>		100	µs	Note 6
Hardware RX_LOS Assert Time	t <sub>loss_off</sub>		100	µs	Note 7
Hardware RATE_SELECT Assert Time	t <sub>rate_high</sub>		1	ms	Note 17
Hardware RATE_SELECT Deassert Time	t <sub>rate_low</sub>		1	ms	Note 17
Software TX_DISABLE Assert Time	t <sub>off_soft</sub>		100	ms	Note 8
Software TX_DISABLE Negate Time	t <sub>on_soft</sub>		100	ms	Note 9
Software Tx_FAULT Assert Time	t <sub>fault_soft</sub>		100	ms	Note 10
Software Rx_LOS Assert Time	t <sub>loss_on_soft</sub>		100	ms	Note 11
Software Rx_LOS Deassert Time	t <sub>loss_off_soft</sub>		100	ms	Note 12
Software Rate_Select Assert Time	t <sub>rate_on_soft</sub>		100	ms	Note 18
Software Rate_Select Deassert Time	t <sub>rate_off_soft</sub>		100	ms	Note 19
Analog parameter data ready	t <sub>data</sub>		1000	ms	Note 13
Serial bus hardware ready	t <sub>serial</sub>		300	ms	Note 14
Serial bus buffer time	t <sub>buf</sub>	20		µs	Note 16
Write Cycle Time	t <sub>write</sub>		40	ms	Note 15
Serial ID Clock Rate	f <sub>serial_clock</sub>		400	kHz	

**Notes:**

1. Time from rising edge of TX\_DISABLE to when the optical output falls below 10% of nominal.
2. Time from falling edge of TX\_DISABLE to when the modulated optical output rises above 90% of nominal.
3. Time from power on or falling edge of Tx\_Disable to when the modulated optical output rises above 90% of nominal.
4. From power on or negation of TX\_FAULT using TX\_DISABLE.
5. Time TX\_DISABLE must be held high to reset the laser fault shutdown circuitry.
6. Time from loss of optical signal to Rx\_LOS Assertion.
7. Time from valid optical signal to Rx\_LOS De-Assertion.
8. Time from two-wire interface assertion of TX\_DISABLE (A2h, byte 110, bit 6) to when the optical output falls below 10% of nominal. Measured from falling clock edge after stop bit of write transaction.
9. Time from two-wire interface de-assertion of TX\_DISABLE (A2h, byte 110, bit 6) to when the modulated optical output rises above 90% of nominal.
10. Time from fault to two-wire interface TX\_FAULT (A2h, byte 110, bit 2) asserted.
11. Time for two-wire interface assertion of Rx\_LOS (A2h, byte 110, bit 1) from loss of optical signal.
12. Time for two-wire interface de-assertion of Rx\_LOS (A2h, byte 110, bit 1) from presence of valid optical signal.
13. From power on to data ready bit asserted (A2h, byte 110, bit 0). Data ready indicates analog monitoring circuitry is functional.
14. Time from power on until module is ready for data transmission over the serial bus (reads or writes over A0h and A2h).
15. Time from stop bit to completion of a 1 – 4 byte write command. Write cycle time is 80 ms max. for a 5 – 8 byte write.
16. Time between STOP and START commands.
17. Time from rising or falling edge of Rate\_Select input until transceiver is successfully passing traffic as designated by RS(0) and RS(1). For Rate\_Select going high, the internal CDR will lock on valid 64b/66b encoded 14.025 Gb/s data within the specified time. For Rate\_Select going low, the internal CDR will be bypassed within the specified time for transmission of valid 8b/10b encoded 8.5 Gb/s or 4.25 Gb/s data.
18. Time from two-wire interface Assertion of Rate\_Select (either RS(0) in A2h, byte 110, bit 3 or RS(1) in A2h, byte 118, bit 3) to when the respective CDR is engaged at 14.025 Gb/s data rate.
19. Time from two-wire interface Deassertion of Rate\_Select (either RS(0) in A2h, byte 110, bit 3 or RS(1) in A2h, byte 118, bit 3) to when the respective CDR is bypassed for low speed 8.5 Gb/s or 4.25 Gb/s operation.

**Table 11. Transceiver Digital Diagnostic Monitor (Real Time Sense) Characteristics**

( $T_C = 0\text{ }^\circ\text{C}$  to  $70\text{ }^\circ\text{C}$ ,  $V_{CC,T}, V_{CC,R} = 3.3\text{ V} \pm 5\%$ )

Parameter	Symbol	Min.	Units	Notes
Transceiver Internal Temperature Accuracy	$T_{INT}$	$\pm 3.0$	$^\circ\text{C}$	Temperature is measured internal to the transceiver. Valid from = $0\text{ }^\circ\text{C}$ to $70\text{ }^\circ\text{C}$ case temperature.
Transceiver Internal Supply Voltage Accuracy	$V_{INT}$	$\pm 0.1$	V	Supply voltage is measured internal to the transceiver and can, with less accuracy, be correlated to voltage at the SFP $V_{CC}$ pin. Valid over $3.3\text{ V} \pm 10\%$ .
Transmitter Laser DC Bias Current Accuracy	$I_{INT}$	$\pm 10$	%	$I_{INT}$ is better than $\pm 10\%$ of the nominal value.
Transmitted Average Optical Output Power Accuracy	$P_T$	$\pm 3.0$	dB	Coupled into 50/125 $\mu\text{m}$ multi-mode fiber. Valid from 100 $\mu\text{W}$ to 500 $\mu\text{W}$ , avg.
Received Average Optical Input Power Accuracy	$P_R$	$\pm 3.0$	dB	Coupled from 50/125 $\mu\text{m}$ multi-mode fiber. Valid from 31 $\mu\text{W}$ to 500 $\mu\text{W}$ , avg.

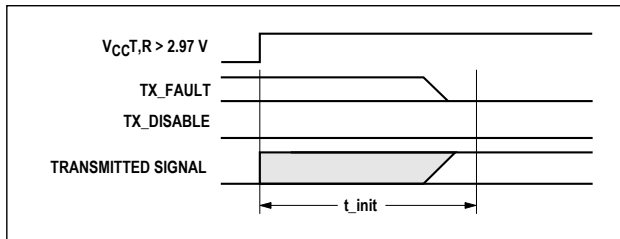

t-init: TX DISABLE NEGATED

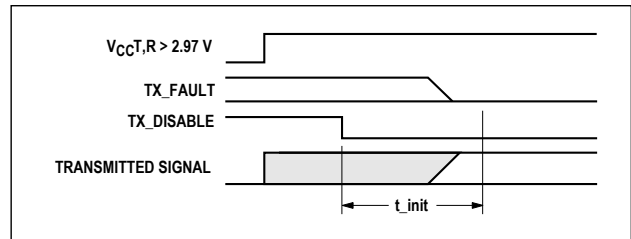

t-init: TX DISABLE ASSERTED

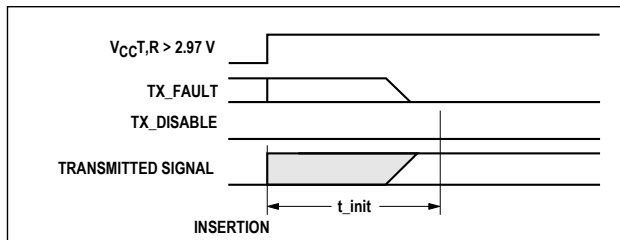

t-init: TX DISABLE NEGATED, MODULE HOT PLUGGED

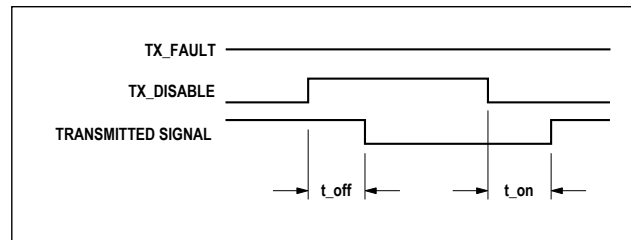

t-off & t-on: TX DISABLE ASSERTED THEN NEGATED

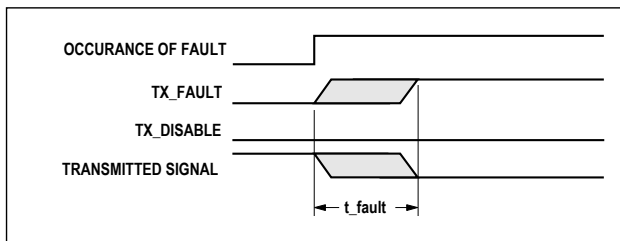

t-fault: TX FAULT ASSERTED, TX SIGNAL NOT RECOVERED

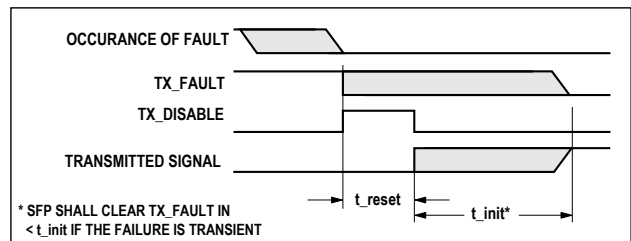

t-reset: TX DISABLE ASSERTED THEN NEGATED, TX SIGNAL RECOVERED

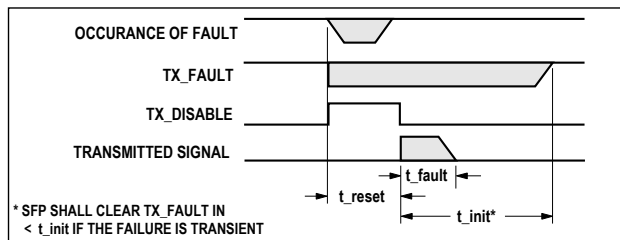

t-fault: TX DISABLE ASSERTED THEN NEGATED, TX SIGNAL NOT RECOVERED

**Figure 5. Transceiver timing diagrams (module installed except where noted)**

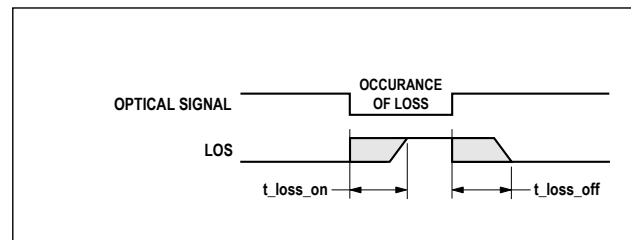

t-loss-on & t-loss-off

**Table 12. EEPROM Serial ID Memory Contents – Address A0h**

Byte #			Byte #		
Decimal	Hex	Description	Decimal	Hex	Description
0	03	SFP physical device	37	00	Hex Byte of Vendor OUI [4]
1	04	SFP function defined by serial ID only	38	17	Hex Byte of Vendor OUI [4]
2	07	LC optical connector	39	6A	Hex Byte of Vendor OUI [4]
3	00		40	41	"A" - Vendor Name ASCII Character
4	00		41	46	"F" - Vendor Name ASCII Character
5	00		42	42	"B" - Vendor Name ASCII Character
6	00		43	52	"R" - Vendor Name ASCII Character
7	60	Short and Intermediate link distance (per FC-PI-5)	44	2D	"-" - Vendor Name ASCII Character
8	40	Shortwave laser without OFC (open fiber control)	45	35	"5" - Vendor Name ASCII Character
9	0C	Multi-mode 50 μm and 62.5 μm and optical media	46	37	"7" - Vendor Name ASCII Character
10	70	400, 800 and 1600 MByte/s FC-PI-5 speed [1]	47	46	"F" - Vendor Name ASCII Character
11	06	64B/66B data at 14.025G & 8B/10B at 8.5G/4.25G	48	35	"5" - Vendor Name ASCII Character
12	8C	14.025 Mbit/s nominal bit rate (14.025 Gb/s)	49	4D	"M" - Vendor Name ASCII Character
13	0A	16/8/4G Independent Tx and Rx Rate Selects	50	5A	"Z" - Vendor Name ASCII Character
14	00		51	20	" " - Vendor Name ASCII Character
15	00		52	20	" " - Vendor Name ASCII Character
16	04	35m of OM2 50/125um fiber at 14.025 Gb/s [2]	53	20	" " - Vendor Name ASCII Character
17	02	15m of OM1 62.5/125um fiber at 14.025 Gb/s [3]	54	20	" " - Vendor Name ASCII Character
18	00		55	20	" " - Vendor Name ASCII Character
19	0A	100m of OM3 50/125um fiber at 14.025 Gb/s [9]	56	20	" " - Vendor Name ASCII Character
20	41	"A" - Vendor Name ASCII Character	57	20	" " - Vendor Name ASCII Character
21	56	"V" - Vendor Name ASCII Character	58	20	" " - Vendor Name ASCII Character
22	41	"A" - Vendor Name ASCII Character	59	20	" " - Vendor Name ASCII Character
23	47	"G" - Vendor Name ASCII Character	60	03	Hex Byte of Laser Wavelength [5]
24	4F	"O" - Vendor Name ASCII Character	61	52	Hex Byte of Laser Wavelength [5]
25	20	" " - Vendor Name ASCII Character	62	00	
26	20	" " - Vendor Name ASCII Character	63		Checksum for Bytes 0-62 [6]
27	20	" " - Vendor Name ASCII Character	64	00	Receiver limiting output. 1W power class
28	20	" " - Vendor Name ASCII Character	65	3A	Hardware Tx_Disable, Tx_Fault, Rx_LOS, Rate_Select
29	20	" " - Vendor Name ASCII Character	66	00	
30	20	" " - Vendor Name ASCII Character	67	00	
31	20	" " - Vendor Name ASCII Character	68 - 83		Vendor Serial Number ASCII characters [7]
32	20	" " - Vendor Name ASCII Character	84 - 91		Vendor Date Code ASCII characters [8]
33	20	" " - Vendor Name ASCII Character	92	68	Digital diagnostics, Internal Cal, Rx Pwr Avg
34	20	" " - Vendor Name ASCII Character	93	FA	Alarms/Warnings, Software Tx_Disable, Tx-Fault, Rx_LOS, Rate_Select
35	20	" " - Vendor Name ASCII Character	94	05	SFF-8472 compliance to revision 11.0
36	00		95		Checksum for Bytes 62-94 [6]
			96 – 255	00	

**Notes:**

- FC-PI-5 speed 1600 MByte/s is a serial bit rate of 14.025 Gb/s. 800 MByte/s is a serial bit rate of 8.5 Gb/s. 400 MByte/s is a serial bit rate of 4.25 Gb/s.
- Link distance with OM2 50/125 μm cable at 8.5 Gb/s is 50 m. Link distance at 4.25 Gb/s is 150 m.
- Link distance with OM1 62.5/125 μm cable at 8.5 Gb/s is 25 m. Link distance at 4.25 Gb/s is 70 m.
- The IEEE Organizationally Unique Identified (OUI) assigned to Avago Technologies is 00-17-64 (3 bytes of Hex).
- Laser Wavelength is represented in 16 unsigned bits. The Hex representation of 850 nm is 0352.
- Addresses 63 and 95 are checksums calculated (per SFF-8472 and SFF-8074) and stored before product shipment.
- Address 68-83 specify the AFBR-57F5MZ ASCII serial number and will vary on a per unit basis.
- Address 84-91 specify the AFBR-57F5MZ ASCII data code and will vary on a per date code basis.
- Link distance with OM3 50/125 μm cable at 8.5 Gb/s is 150 m. Link distance at 4.25 Gb/s is 380 m.

**Table 13. EEPROM Serial ID Memory Contents – Enhanced Feature Set Memory (Address A2h)**

Byte # Decimal	Notes	Byte # Decimal	Notes	Byte # Decimal	Notes
0	Temp H Alarm MSB <sup>[1]</sup>	26	Tx Pwr L Alarm MSB <sup>[4]</sup>	104	Real Time Rx Pwr MSB <sup>[5]</sup>
1	Temp H Alarm LSB <sup>[1]</sup>	27	Tx Pwr L Alarm LSB <sup>[4]</sup>	105	Real Time Rx Pwr LSB <sup>[5]</sup>
2	Temp L Alarm MSB <sup>[1]</sup>	28	Tx Pwr H Warning MSB <sup>[4]</sup>	106	Reserved
3	Temp L Alarm LSB <sup>[1]</sup>	29	Tx Pwr H Warning LSB <sup>[4]</sup>	107	Reserved
4	Temp H Warning MSB <sup>[1]</sup>	30	Tx Pwr L Warning MSB <sup>[4]</sup>	108	Reserved
5	Temp H Warning LSB <sup>[1]</sup>	31	Tx Pwr L Warning LSB <sup>[4]</sup>	109	Reserved
6	Temp L Warning MSB <sup>[1]</sup>	32	Rx Pwr H Alarm MSB <sup>[5]</sup>	110	Status/Control - See Table 14
7	Temp L Warning LSB <sup>[1]</sup>	33	Rx Pwr H Alarm LSB <sup>[5]</sup>	111	Status/Control - See Table 15
8	Vcc H Alarm MSB <sup>[2]</sup>	34	Rx Pwr L Alarm MSB <sup>[5]</sup>	112	Flag Bits - See Table 16
9	Vcc H Alarm LSB <sup>[2]</sup>	35	Rx Pwr L Alarm LSB <sup>[5]</sup>	113	Flag Bits - See Table 16
10	Vcc L Alarm MSB <sup>[2]</sup>	36	Rx Pwr H Warning MSB <sup>[5]</sup>	114	Reserved
11	Vcc L Alarm LSB <sup>[2]</sup>	37	Rx Pwr H Warning LSB <sup>[5]</sup>	115	Reserved
12	Vcc H Warning MSB <sup>[2]</sup>	38	Rx Pwr L Warning MSB <sup>[5]</sup>	116	Flag Bits - See Table 16
13	Vcc H Warning LSB <sup>[2]</sup>	39	Rx Pwr L Warning LSB <sup>[5]</sup>	117	Flag Bits - See Table 16
14	Vcc L Warning MSB <sup>[2]</sup>	40-55	Control Settings - See Table 18	118	Status/Control - See Table 17
15	Vcc L Warning LSB <sup>[2]</sup>	56-94	External Calibration Constants <sup>[6]</sup>	119-127	Reserved
16	Tx Bias H Alarm MSB <sup>[3]</sup>	95	Checksum for Bytes 0-94 <sup>[7]</sup>	128-247	Customer Writeable
17	Tx Bias H Alarm LSB <sup>[3]</sup>	96	Real Time Temperature MSB <sup>[1]</sup>	248-255	Vendor Specific
18	Tx Bias L Alarm MSB <sup>[3]</sup>	97	Real Time Temperature LSB <sup>[1]</sup>		
19	Tx Bias L Alarm LSB <sup>[3]</sup>	98	Real Time Vcc MSB <sup>[2]</sup>		
20	Tx Bias H Warning MSB <sup>[3]</sup>	99	Real Time Vcc LS <sup>[2]</sup>		
21	Tx Bias H Warning LSB <sup>[3]</sup>	100	Real Time Tx Bias MSB <sup>[3]</sup>		
22	Tx Bias L Warning MSB <sup>[3]</sup>	101	Real Time Tx Bias LSB <sup>[3]</sup>		
23	Tx Bias L Warning LSB <sup>[3]</sup>	102	Real Time Tx Power MSB <sup>[4]</sup>		
24	Tx Pwr H Alarm MSB <sup>[4]</sup>	103	Real Time Tx Power LSB <sup>[4]</sup>		
25	Tx Pwr H Alarm LSB <sup>[4]</sup>				

**Notes:**

1. Temperature (Temp) is decoded as a 16 bit signed twos complement integer in increments of 1/256 °C.
2. Supply Voltage (Vcc) is decoded as a 16 bit unsigned integer in increments of 100 μV.
3. Laser bias current (Tx Bias) is decoded as a 16 bit unsigned integer in increments of 2 μA.
4. Transmitted average optical power (Tx Pwr) is decoded as a 16 bit unsigned integer in increments of 0.1 μW.
5. Received average optical power (Rx Pwr) is decoded as a 16 bit unsigned integer in increments of 0.1 μW.
6. Bytes 56-94 are not intended for use with AFBR-57F5MZ, but have been set to default values per SFF-8472.
7. Byte 95 is a checksum calculated (per SFF-8472) and stored before product shipment.



**Table 14. EEPROM Serial ID Memory Contents – Soft Commands (Address A2h, Byte 110)**

Bit #	Status/Control Name	Description	Notes
7	TX_DISABLE State	Digital state of TX_DISABLE Input Pin (1 = TX_DISABLE asserted)	Note 1
6	Soft TX_DISABLE Control	Read/write bit for changing digital state of TX_DISABLE function	Note 1, 2
5	RS(1) State	Digital state of TX Rate_Select Input Pin RS(1) (1 = Rate High asserted)	
4	RS(0) State	Digital state of RX Rate_Select Input Pin RS(0) (1 = Rate High asserted)	
3	Soft RS(0) Control	Read/write bit for changing digital state of Rx Rate_Select RS(0) function	Note 3
2	TX_FAULT State	Digital state of TX_FAULT Output Pin (1 = TX_FAULT asserted)	Note 1
1	RX_LOS State	Digital state of SFP RX_LOS Output Pin (1 = RX_LOS asserted)	Note 1
0	Data Ready (Bar)	Indicates transceiver is powered and real time sense data is ready (0 = Data Ready)	

Notes:

1. The response time for soft commands of the AFBR-57F5MZ is 100msec as specified by MSA SFF-8472.
2. Bit 6 is logic OR'd with the SFP TX\_DISABLE input pin 3 .... either asserted will disable the SFP transmitter.
3. Bit 3 is logic OR'd with the SFP RS(0) RX Rate\_Select input pin 7 .... either asserted will set receiver to Rate = High.

**Table 15. EEPROM Serial ID Memory Contents – Soft Commands (Address A2h, Byte 111)**

Bit #	Status/Control Name	Description	Notes
4-7	Reserved		
3	OWRAP FORWARD Control Bit	Logic Low = FORWARD disabled. Logic High = FORWARD enabled. When used in combination with OWRAP enable, FORWARD routes incoming SFP Rx optical data to both the Tx optical output and the Rx electrical output. Enabling sets bit 2 and clears all other bits in byte 111.	
2	OWRAP Control Bit	Logic Low = OWRAP disabled. Logic High = OWRAP enabled. When enabled, OWRAP routes incoming SFP Rx optical data to the Tx optical output. Enabling clears all other bits in byte 111.	
1	EWRAP FORWARD Control Bit	Logic Low = FORWARD disabled. Logic High = FORWARD enabled. When used in combination with EWRAP enable, FORWARD routes incoming SFP Tx electrical data to both Rx electrical output and Tx optical output. Enabling sets bit 0 and clears all other bits in byte 111.	
0	EWRAP Control Bit	Logic Low = EWRAP disabled. Logic High = EWRAP enabled. When enabled, EWRAP routes incoming SFP Tx electrical data to the Rx electrical output. Enabling clears all other bits in byte 111.	

**Table 16. EEPROM Serial ID Memory Contents – Alarms and Warnings (Address A2h, Bytes 112, 113, 116, 117)**

Byte	Bit	Flag Bit Name	Description
112	7	Temp High Alarm	Set when transceiver internal temperature exceeds high alarm threshold
	6	Temp Low Alarm	Set when transceiver internal temperature exceeds low alarm threshold
	5	Vcc High Alarm	Set when transceiver internal supply voltage exceeds high alarm threshold
	4	Vcc Low Alarm	Set when transceiver internal supply voltage exceeds low alarm threshold
	3	Tx Bias High Alarm	Set when transceiver laser bias current exceeds high alarm threshold
	2	Tx Bias Low Alarm	Set when transceiver laser bias current exceeds low alarm threshold
	1	Tx Power High Alarm	Set when transmitted average optical power exceeds high alarm threshold
	0	Tx Power Low Alarm	Set when transmitted average optical power exceeds low alarm threshold
113	7	Rx Power High Alarm	Set when received average optical power exceeds high alarm threshold
	6	Rx Power Low Alarm	Set when received average optical power exceeds low alarm threshold
	0-5	Reserved	
116	7	Temp High Warning	Set when transceiver internal temperature exceeds high warning threshold
	6	Temp Low Warning	Set when transceiver internal temperature exceeds low warning threshold
	5	Vcc High Warning	Set when transceiver internal supply voltage exceeds high warning threshold
	4	Vcc Low Warning	Set when transceiver internal supply voltage exceeds low warning threshold
	3	Tx Bias High Warning	Set when transceiver laser bias current exceeds high warning threshold
	2	Tx Bias Low Warning	Set when transceiver laser bias current exceeds low warning threshold
	1	Tx Power High Warning	Set when transmitted average optical power exceeds high warning threshold
	0	Tx Power Low Warning	Set when transmitted average optical power exceeds low warning threshold
117	7	Rx Power High Warning	Set when received average optical power exceeds high warning threshold
	6	Rx Power Low Warning	Set when received average optical power exceeds low warning threshold
	0-5	Reserved	

**Table 17. EEPROM Serial ID Memory Contents – Soft Commands (Address A2h, Byte 118)**

Bit #	Status/Control Name	Description	Notes
4-7	Reserved		
3	Soft RS(1) Control	Read/write bit for changing digital state of Tx Rate_Select RS(1) function	Note 1
2	Reserved		
1	Power Level State	Always set to zero. Value of zero indicates Power Level 1 operation (1 Watt max)	
0	Power Level Select	Unused. This device supports power level zero (1 Watt max) only.	

Notes:

1. Bit 3 is logic OR'd with the SFP RS(1) TX Rate\_Select input pin 9 .... either asserted will set transmitter to Rate = High.

**Table 18. Signal Integrity Feature Configuration Bytes (2-Wire Address A2h)**

Byte	Name	Description
40	Tx Input EQ Setting for RS(1) = High	Defines SFP incoming electrical Tx equalization setting for Tx_Rate = High [ie. RS(1)=High] The SFP transceiver will support two EQ settings based on LSB. With LSB = 0, the Tx input EQ is set to 0 dB (no EQ). With LSB = 1, the Tx input EQ is set to 6 dB gain at 7 GHz. Writing FFh to this byte resets to factory settings, EQ = 0 dB.
41	Tx Input EQ Setting for RS(1) = Low	Defines SFP incoming electrical Tx equalization setting for Tx_Rate = Low [ie. RS(1)=Low] The SFP transceiver will support two EQ settings based on LSB. With LSB = 0, the Tx input EQ is set to 0 dB (no EQ). With LSB = 1, the Tx input EQ is set to 6 dB gain at 7 GHz. Writing FFh to this byte resets to factory settings, EQ = 0 dB.
42	Rx Output Pre Emphasis Setting for RS(0) = High	Defines SFP output electrical Rx pre-emphasis setting for Rx_Rate = High [ie. RS(0)=High] The SFP transceiver will support 8 Pre Emphasis amplitude settings in the lower 3 bits of this byte. Emphasis can be varied from 0 dB to 6 dB in eight non-linear steps. A value of 0 results in 0 dB emphasis. Writing FFh to this byte resets to factory settings, EMPH = 0 dB.
43	Rx Output Pre Emphasis Setting for RS(0) = Low	Defines SFP output electrical Rx pre-emphasis setting for Rx_Rate = Low [ie. RS(0)=Low] The SFP transceiver will support 8 Pre Emphasis amplitude settings in the lower 3 bits of this byte. Emphasis can be varied from 0 dB to 6 dB in eight non-linear steps. A value of 0 results in 0 dB emphasis. Writing FFh to this byte resets to factory settings, EMPH = 0 dB.
44-55	Unallocated	Contents 00h.

Note: Checksum at address A2h byte 95 will be updated within 100 ms of a value change in these bytes.

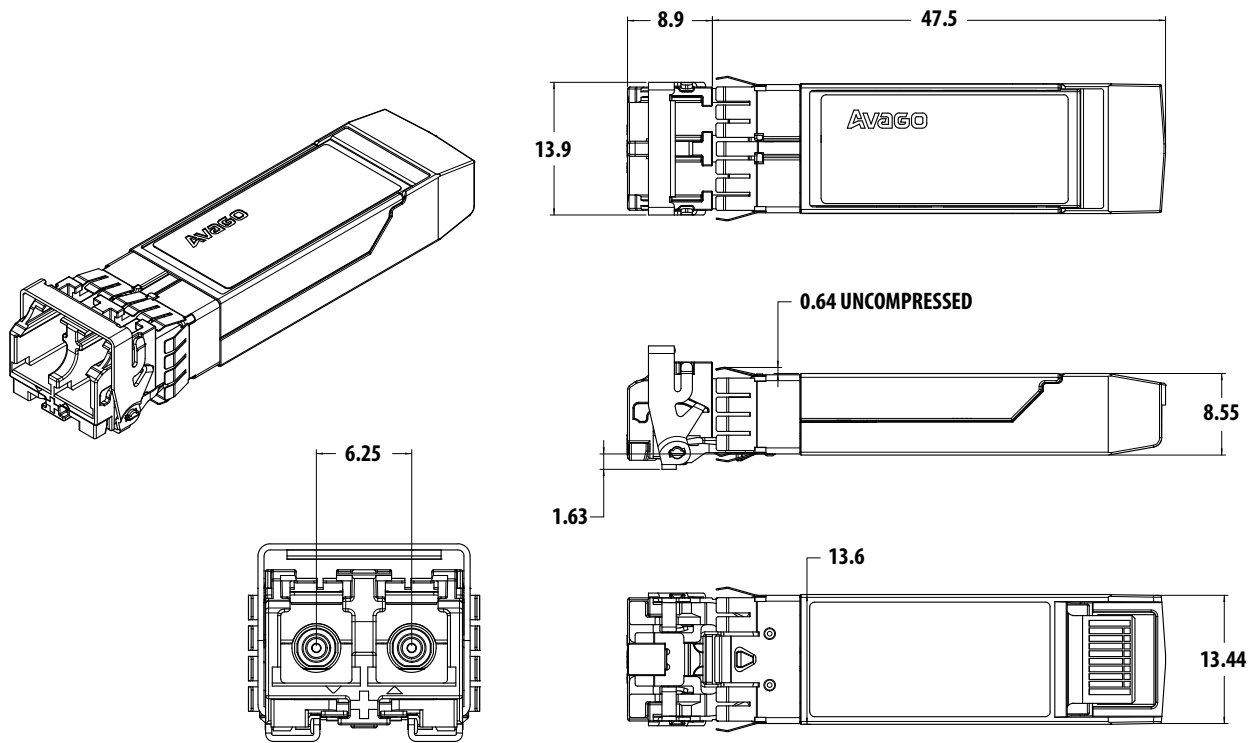

Figure 6. Module drawing



AFBR-57F5MZ  
 850nm LASER PROD  
 21CFR(J) CLASS 1  
 CHINA YYWW  
 SN: A@YYWWAXXXX



Figure 7. Module Label

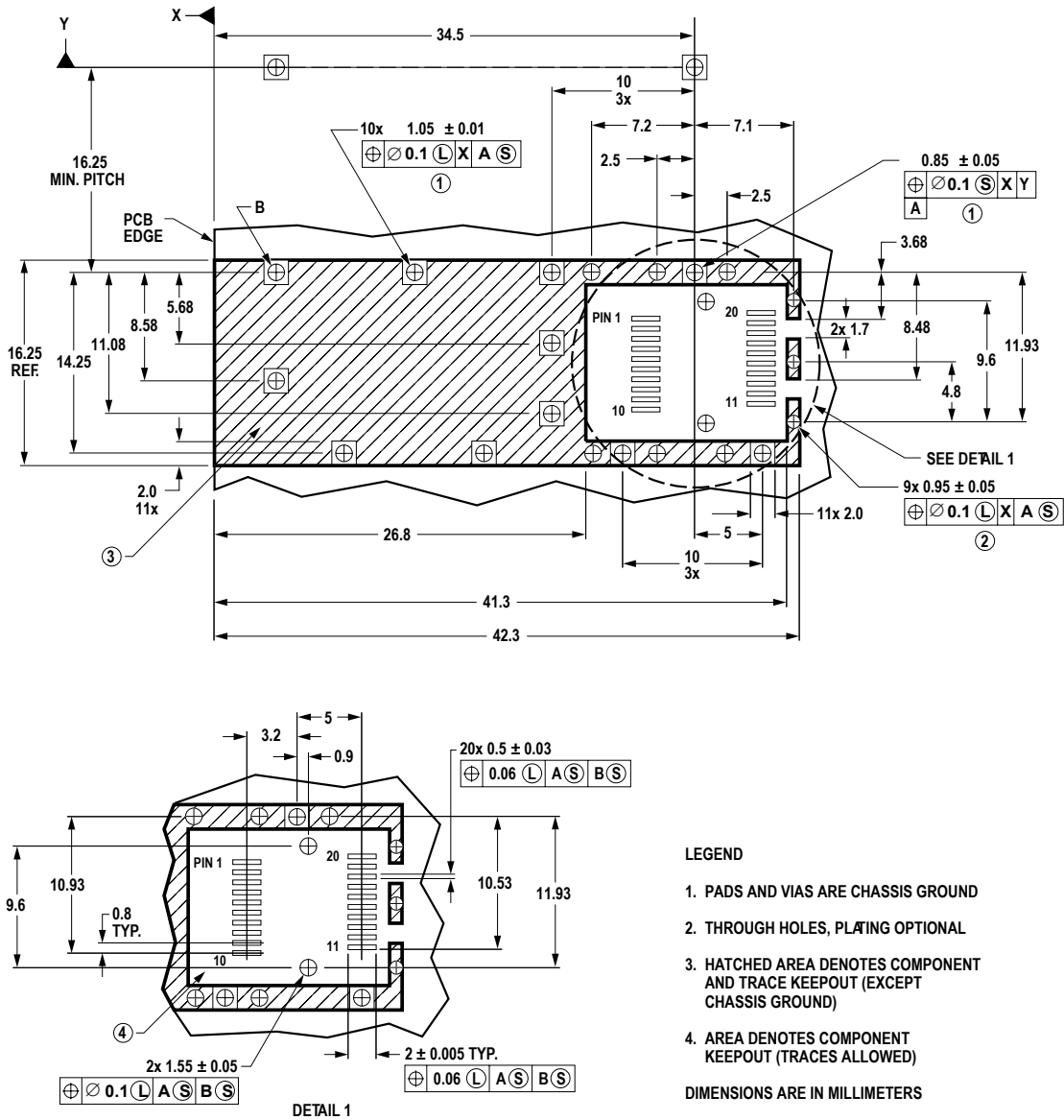

Figure 8. SFP host board mechanical layout

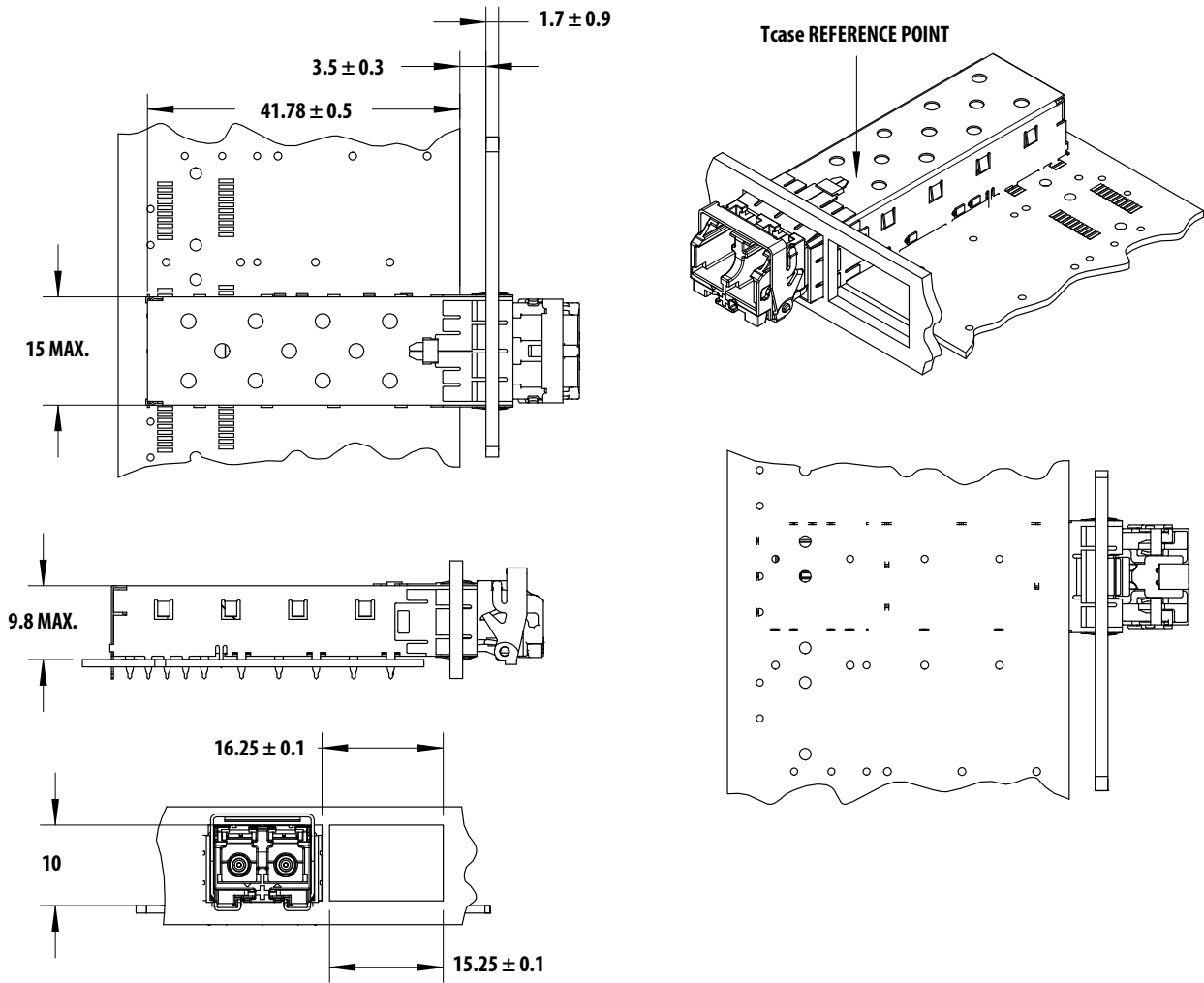

Figure 9. SFP Assembly drawing

### Customer Manufacturing Processes

This module is pluggable and is not designed for aqueous wash, IR reflow, or wave soldering processes.

## Appendix I. Rate Select Control

RX and TX rates can be independently controlled by either hardware input pins or via register writes. Module electrical input pins 7 and 9 are used to select RX and TX rate respectively. Status of each logic level is reflected to register byte 110 bit 4 and 5 on address A2h as shown in the diagram below. RX and TX rates can also be controlled by register writes to byte 110 bit 3 and 118 bit 3. Power on default of these bits are logic low. Hardware and software control inputs are OR'd to allow flexible control.

### RS0 RX Rate Select control flow

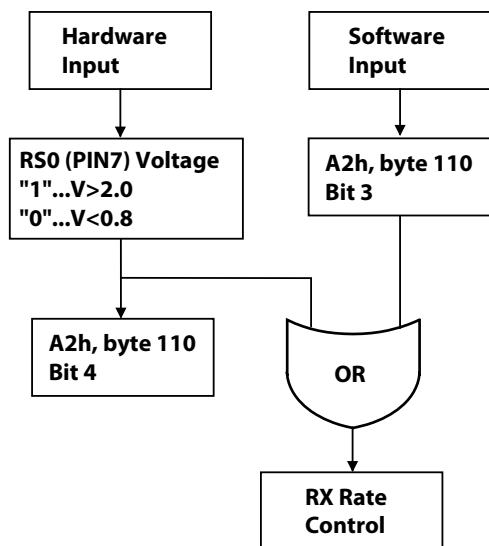

### RS1 TX Rate Select control flow

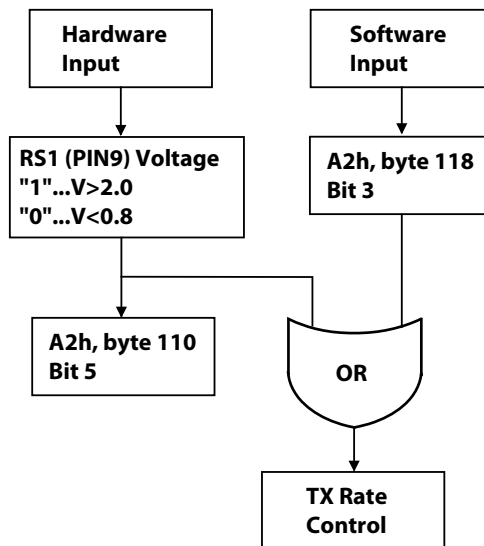

RS0 Control Input		RX Operation	
Hardware	Software		
0	0	4/8G FC	RX CDR bypassed
0	1	16G FC	RX CDR enabled
1	0	16G FC	
1	1	16G FC	

RS1 Control Input		TX Operation	
Hardware	Software		
0	0	4/8G FC	TX CDR bypassed
0	1	16G FC	TX CDR enabled
1	0	16G FC	
1	1	16G FC	

For product information and a complete list of distributors, please go to our website: [www.avagotech.com](http://www.avagotech.com)

Avago, Avago Technologies, and the A logo are trademarks of Avago Technologies in the United States and other countries. Data subject to change. Copyright © 2005-2013 Avago Technologies. All rights reserved. Obsoletes AV02-2898EN. AV02-3165EN - May 16, 2013

**AVAGO**  
TECHNOLOGIES