



The Future of Analog IC Technology™

EV1529DR-00A

Fixed Frequency Step-Up Converter LCD Backlight Plus Flash Evaluation Board

GENERAL DESCRIPTION

The EV1529DR-00A evaluation board is designed to drive 2 strings of up to 4 backlight LEDs to 30mA and a 4-LED flash string to 150mA from a single Lithium-Ion battery. The board is set up to obtain 20mA backlight current, 40mA preview current and 100mA flash current. All the LED currents can be adjusted by resistors RS1, RS2, and RS3 on the evaluation board.

The MP1529 switches at 1.2MHz and allows the use of tiny, low cost capacitors and small inductors. High frequency PWM dimming is made possible through EN1. The MP1529 includes built-in open-LED over-voltage protection, cycle-by-cycle current limit, over-temperature shutdown, input under-voltage control and integrated soft-start.

FEATURES

- High Efficiency
- 2.7V to 4.2V Input Voltage Range
- Tiny Capacitors and Inductors Due to 1.2MHz Fixed Frequency Operation
- LCD Backlight to 30mA, Flash to 150mA
- Independent Backlight, Preview and Flash Current Adjustment
- High Frequency PWM Dimming
- Surface-Mount Components
- Fully Assembled and Tested

APPLICATIONS

- PDAs
- Cellular Phones
- Digital Still Cameras
- Digital Video Cameras

ELECTRICAL SPECIFICATIONS

| Parameter | Symbol | Value | Units |
|-------------------------|---------------------|---------|-------|
| Supply Voltage | V _{IN} | 2.7-4.2 | V |
| LED Current (Backlight) | I _{LED_BL} | 20 | mA |
| LED Current (Preview) | I _{LED_PV} | 40 | mA |
| LED Current (Flash) | I _{LED_FL} | 100 | mA |

"MPS" and "The Future of Analog IC Technology" are Trademarks of Monolithic Power Systems, Inc.

EV1529DR-00A EVALUATION BOARD



(L x W x H) 2.2" x 1.8" x 0.4"
(5.5cm x 4.8cm x 1.0cm)

| Board Number | MPS IC Number |
|--------------|---------------|
| EV1529DR-00A | MP1529DR |

EVALUATION BOARD SCHEMATIC

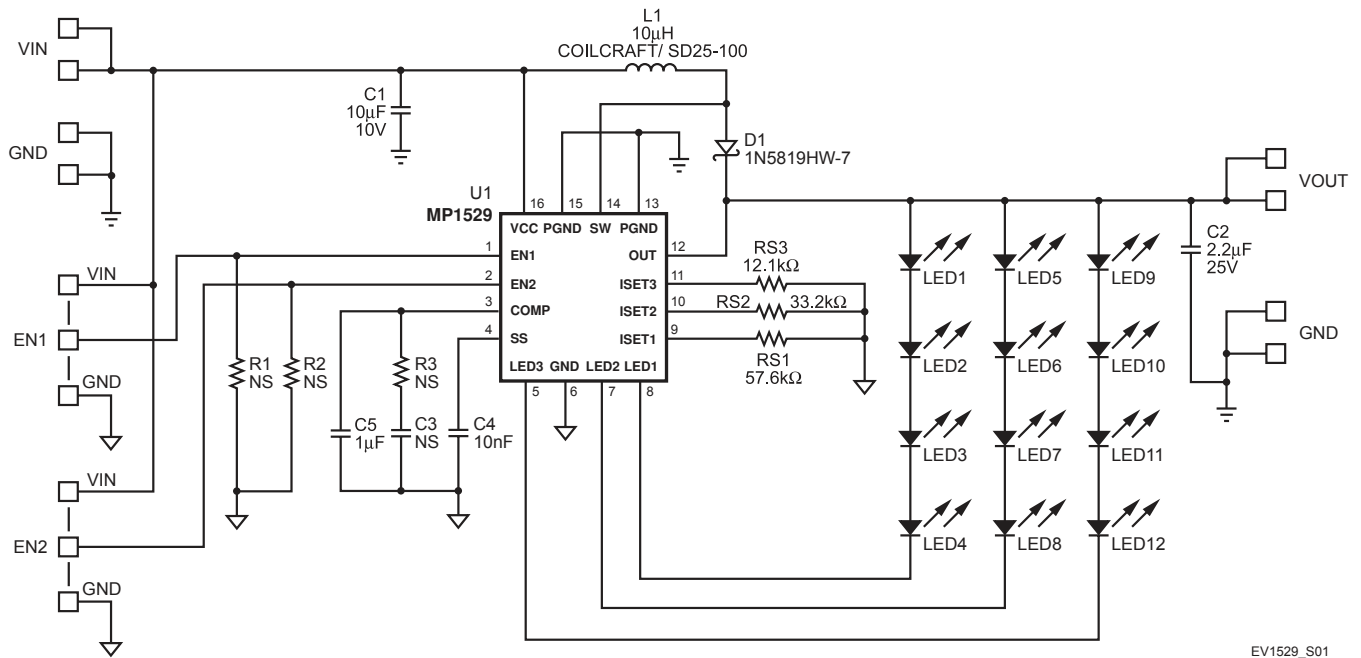

EV1529_S01

EV1529DR-00A BILL OF MATERIALS

| Qty | Ref | Value | Description | Package | Manufacturer | Manufacturer P/N |
|-----|---|--------|-----------------------------|---------|--------------|------------------|
| 1 | C1 | 10µF | Ceramic Capacitor, 10V, X5R | 1210 | TDK | C3225X5R1A106K |
| 1 | C2 | 2.2µF | Ceramic Capacitor, 25V, X7R | 1210 | TDK | C3225X7R1E225M |
| 1 | C3 | | Do Not Stuff | | | |
| 1 | C4 | 10nF | Ceramic Capacitor, 50V, X7R | 0805 | TDK | C2012X7R1H103K |
| 1 | C5 | 1µF | Ceramic Capacitor, 25V, X5R | 0805 | TDK | C2012X5R1E105K |
| 1 | D1 | | Diode Schottky, 40V, 1A | SOD123 | Diodes Inc. | 1N5819HW-7 |
| 1 | L1 | 10µH | Inductor, 1.8A | SMD | Coiltronics | SD25-100 |
| 12 | LED1, LED2, LED3, LED4, LED5, LED6, LED7, LED8, LED9, LED10, LED11, LED12 | | Not Stuffed | | | |
| 3 | R1, R2, R3 | | Not Stuffed | | | |
| 1 | RS1 | 57.6kΩ | Resistor, 1% | 0603 | Any | |
| 1 | RS2 | 33.2kΩ | Resistor, 1% | 0603 | Any | |
| 1 | RS3 | 12.1kΩ | Resistor, 1% | 0603 | Any | |
| 1 | U1 | | Step-Up Converter | QFN16 | MPS | MP1529DR |

PRINTED CIRCUIT BOARD LAYOUT

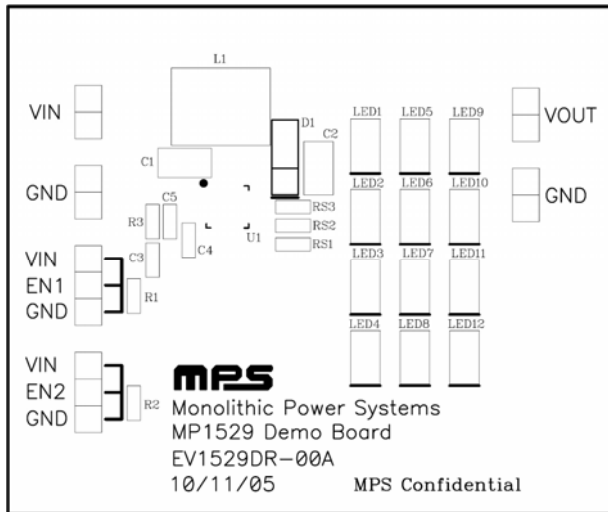

Figure 1—Top Silk Layer

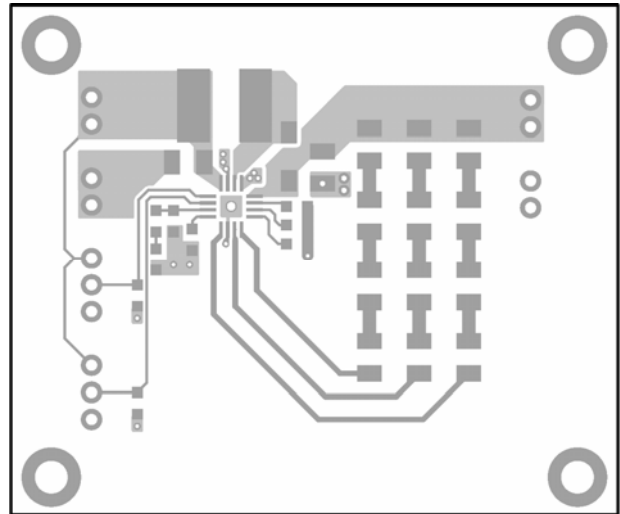

Figure 2—Top Layer

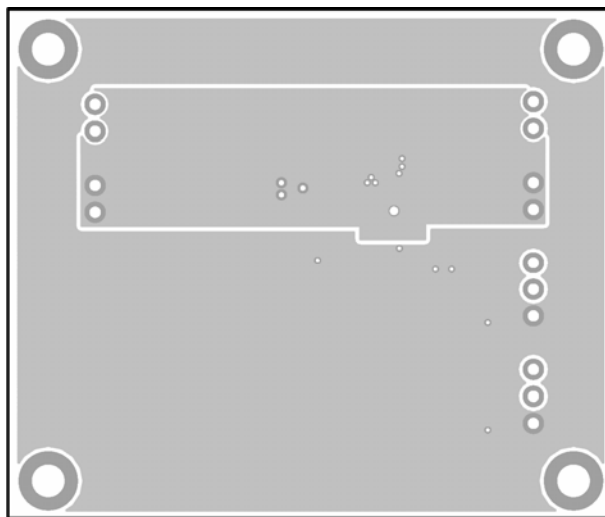

Figure 3—Bottom Layer

QUICK START GUIDE

The LED currents at backlight mode, backlight plus review mode and flash mode are set to 20mA, 40mA, and 100mA, respectively on this board. The board layout accommodates mostly common used inductors and output capacitors.

1. Preset Power Supply to $2.7V \leq V_{IN} \leq 4.2V$.
2. Turn Power Supply off.
3. Connect Power Supply terminals to:
 - a. Positive (+): VIN
 - b. Negative (-): GND
4. Solder the first backlight LED string to LED1 - LED4.

Solder the second backlight LED string to LED5 – LED8.

Solder the flash LED string to LED9 – LED12.

Set EN1 and EN2 based on the Enable Operation Table below. Connect EN1, EN2 to VIN to set them “H” and to GND to set them “L”.

| Mode | EN1 | EN2 | Strings 1+2: LCD Backlight LEDs | String 3: Flash LEDs |
|------------------------|---------|-----|---------------------------------|----------------------|
| Off | L | L | Off | Off |
| Backlight | H (PWM) | L | On (PWM) | Off |
| Backlight plus Preview | H (PWM) | H | On (PWM) | Preview current |
| Flash | L | H | Off | Flash current |

5. Turn Power Supply on after making connections.

The LED currents can be adjusted by changing the values of resistors RS1, RS2, and RS3. $V_{SET} = 1.216V$.

$$RS1 = \frac{950 \times V_{SET}}{I_{LED_BL}}$$

$$RS2 = \frac{1100 \times V_{SET}}{I_{LED_PV}}$$

$$RS3 = \frac{1000 \times V_{SET}}{I_{LED_FL}}$$

For examples, If $I_{LED_BL} = 10mA$, then

$$RS1 = \frac{950 \times 1.216}{10} = 115.52k\Omega \text{ (Use a } 115k\Omega \text{ 1\% resistor)}$$

If $I_{LED_PL} = 20mA$, then

$$RS2 = \frac{1100 \times 1.216}{20} = 66.88k\Omega \text{ (Use a } 66.5k\Omega \text{ 1\% resistor)}$$

If $I_{LED_FL} = 150mA$, then

$$RS3 = \frac{1000 \times 1.216}{150} = 8.11k\Omega \text{ (Use a } 8.06k\Omega \text{ 1\% resistor)}$$

NOTICE: The information in this document is subject to change without notice. Please contact MPS for current specifications. Users should warrant and guarantee that third party Intellectual Property rights are not infringed upon when integrating MPS products into any application. MPS will not assume any legal responsibility for any said applications.