

TECHNICAL SPECIFICATIONS

- SHELLS : TIN PLATED STEEL
- INSULATOR MATERIAL : SELF EXTINGUISHING THERMO-PLASTIC TO UL CLASS 94 V0.
- CONTACTS DIA ON ACTIVE AREA : Ø1 MM.
- CONTACTS MATERIAL : COPPER ALLOY
- CONTACT PLATING : Pd(+Au Flash) 0.76 µ min. over 1.27µ min.
- OPERATING TEMPERATURE: -55°C +125°C
- OPERATING CURRENT : 5 A PER CONTACT
- CONTACT RESISTANCE : ≤25mΩ
- INSULATION RESISTANCE: ≥5000 MΩ
- MAXIMUM VOLTAGE : 1000 V.r.m.s
- MECHANICAL ENDURANCE : 500 MATINGS
- DAMP HEAT : 21 DAYS
- TORQUE REQUIREMENT : 0.4Nm MAX

"This LF product meets European Union Directives and other country regulations as described in GS-47-0004"
 The housing will withstand exposure to 260°C peak temperature for 3.5 seconds in a wave solder application with a 1.6mm minimum thick circuit board.

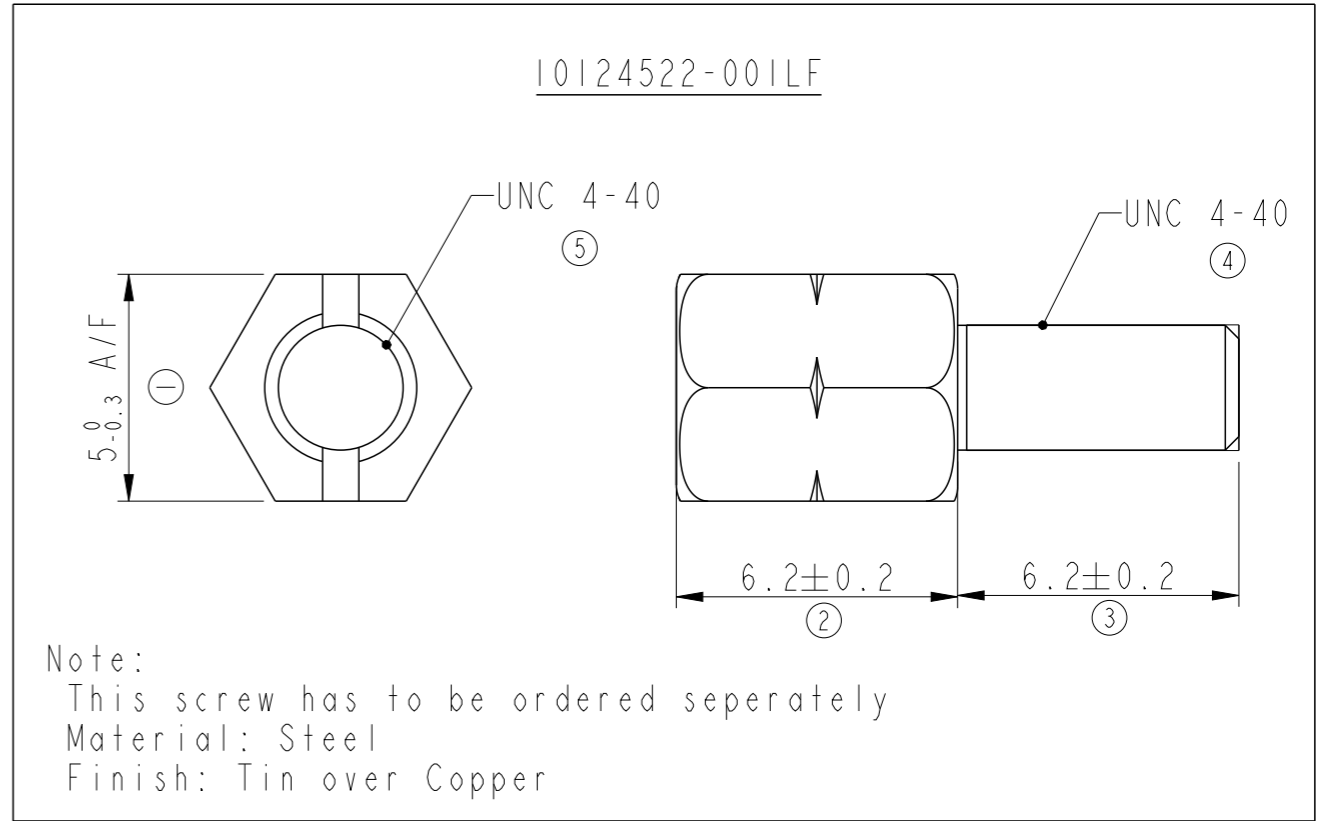

Note:
 This screw has to be ordered seperately
 Material: Steel
 Finish: Tin over Copper

D E S 09 S 9 65 T 121 LF

SERIES	LEAD FREE
SHELL SIZE	SPECIAL CODE
OPTION-1	SINGLE METAL BRACKET & HARPOON
S- RIVETED SPACER	SHELL PLATING
	T-STD. TIN over Cu
NO. OF CONTACTS	CONTACT PLATING
09	65 -500 MATINGS CYCLES
CONTACTS	TERMINATION TYPE
S - SOCKET	9-ANGLED SPILL 2.84mm BETWEEN ROWS

Copyright FCI.



spec ref	-	dr	Paul Mithun	2014/07/16	projection	mm	size	A3	scale	2:1
tolerance std	ISO 406 ISO 1101	eng	Paul Mithun	2014/08/14			ecn no	ELX-18553-1		
	TOLERANCES UNLESS OTHERWISE SPECIFIED	chr	-	-			rel level	Released		
surface	linear	appr	K-Paul Biju	2014/08/14	product family	D-SUB	dwg no	10124522	rev	B
	angular	www.fci.com		cat. no.	-	Product - Customer Drw	sheet	1 of 1		