

IN CASE OF E652XXXXXX1X000 WITHOUT LED

DIAGRAM TAMPOPRINT WHITE (NOT FOR E652XXXXXX1X000)

NOTES:
1. GROUND IS NOT CONNECTED

TABLE OF LENGHT TOLERANCES		
OVER	UP TO AND INCLUDING	TOLERANCE
0	500	-10/+20
500	1000	±20
1000	3000	±30
3000	5000	±40
5000	10000	±50
10000	15000	±100
15000	20000	±150
20000		±L/100

BILL OF MATERIALS

ITEM	QTY.	DESCRIPTION	MATERIAL	FINISH
12	0/2	INTEGRATED GASKET	NBR	-
11	0/2	WASHER	NBR	-
10	0/2	SCREW M3x27	STEEL	ZINC
9	0/2	FLAT GASKET	NBR/SILICONE	-
8	0/2	PROFILE GASKET	NBR/SILICONE	-
7	0/2	SCREW M3x25	STEEL	ZINC
6	2	LABEL WHITE	ABS	-
5	0/2	PCB	-	-
4	2	INSERT DIN A	PA66+25%G V0	-
3	8	CONTACT DIN	BRASS	SILVER
2	-	MOULDING MATERIAL	PP	-
1	-	CABLE (SEE SHEET 3)	-	-

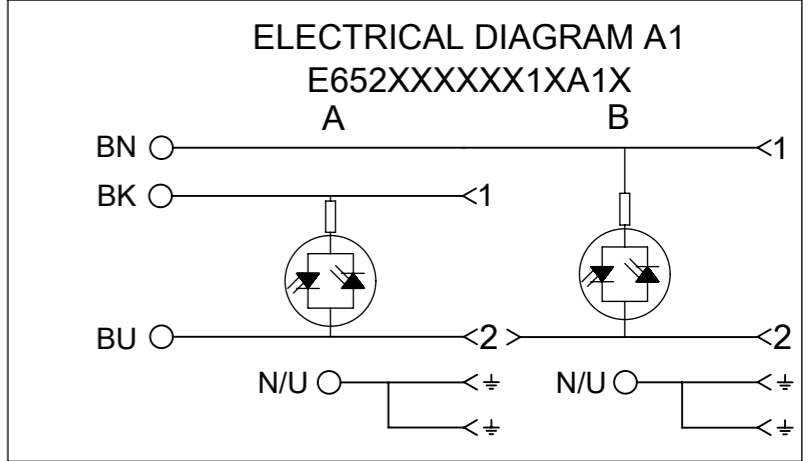
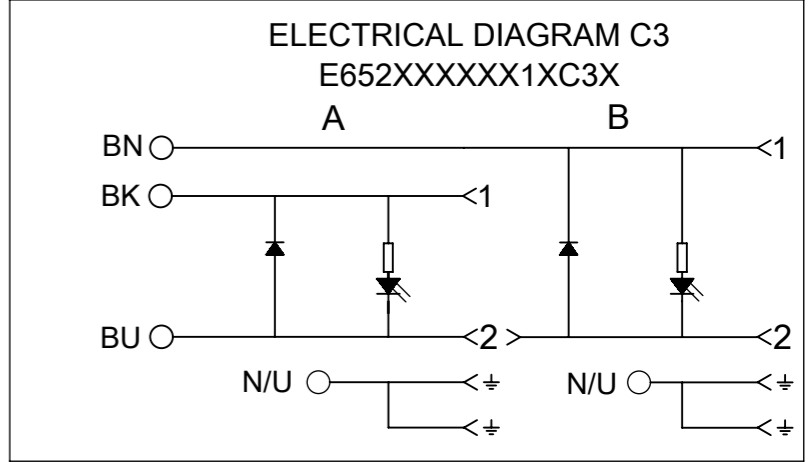
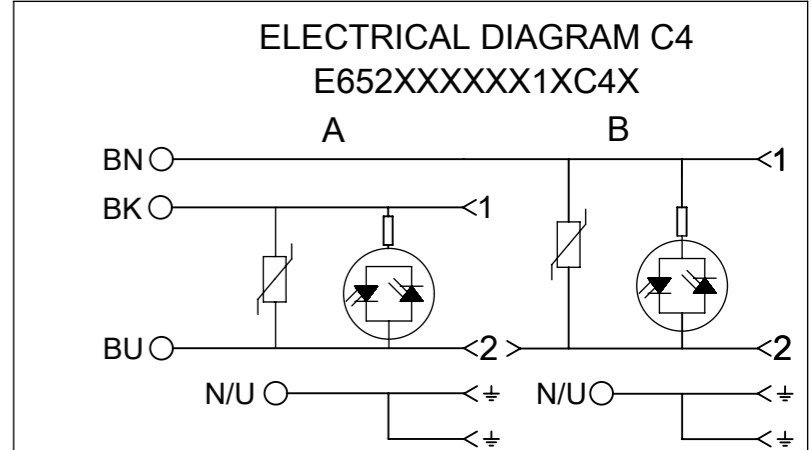
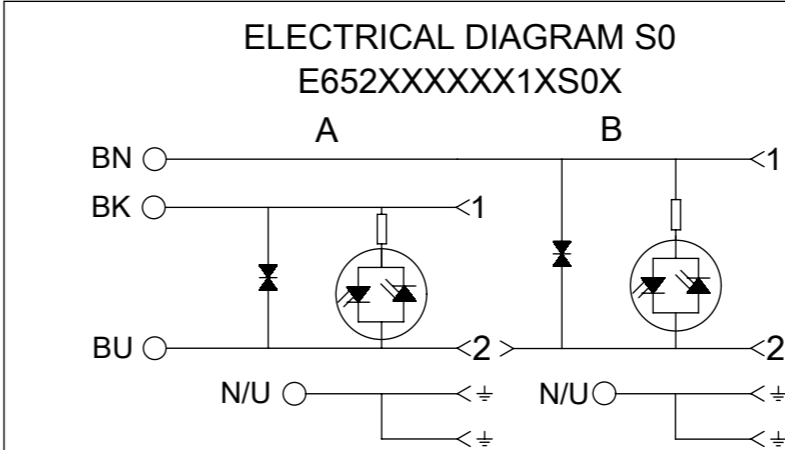
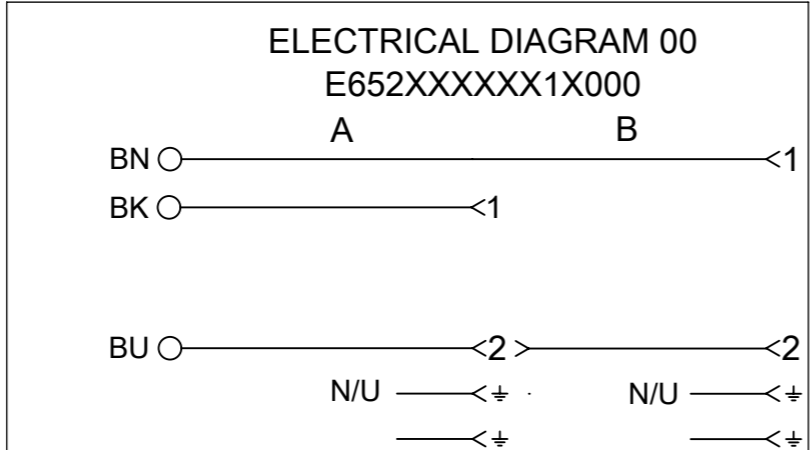

NOTES :

ELECTRICAL - CURRENT : MAX. 5.0A
 CONTACT RESISTANCE : ≤15 milliohms MAX.
 INSULATION RESISTANCE : 100 Megaohms MIN.
 PHYSICAL - OPERATING TEMPERATURE WITH :
 NITRILE RUBBER (NBR) GASKET : -40°C TO +90°C
 LIVE CONTACT DISTANCE :
 FORM A - 18.00mm
 ENVIRONMENTAL - IP65 SEALING PROTECTION(FIXING SCREW)

FUNCTIONAL SYMBOLS	THIS DRAWING CONTAINS INFORMATION THAT IS PROPRIETARY TO MOLEX ELECTRONIC TECHNOLOGIES, LLC AND SHOULD NOT BE USED WITHOUT WRITTEN PERMISSION	CURRENT REV DESC: TOL. TABLE UPDATED	
△/A = 0	mm	SCALE	1:1
△/E = 0	GENERAL TOLERANCES (UNLESS SPECIFIED)		
△/V = 0	ANGULAR TOL ± 1.0°		
DIVISIONAL SYMBOLS	4 PLACES ±	3 PLACES ±	2 PLACES ± 0.05
	1 PLACE ± 0.3	0 PLACES ± 0.5	
DRAFT WHERE APPLICABLE MUST REMAIN WITHIN DIMENSIONS	THIRD ANGLE PROJECTION	DRAWING	SERIES
		A3-SIZE	121055
EC NO: 642619		2020/07/20	
DRWN: SSM		2020/09/04	
CHK'D: RSILLER		2020/09/04	
APPR: RSILLER		2020/09/04	
INITIAL REVISION:		DOCUMENT NUMBER	
DRWN: APAWLAK01		1210550123	
APPR: MIWASIECZKO		PSD 000 A1	
MATERIAL NUMBER		CUSTOMER	
SEE SHEET 3		GENERAL MARKET	
SHEET NUMBER		1 OF 3	

ENGINEERING NO. - NUMERICAL CODE (Available parts see PART LIST table. Others on request).

E652 XX XXXX 1 XXXX

E - Packing without bags
W - Single packing
Q - Quick packing

Cable type:
See Table 1

Cable Cross Section Area:
See Table 1

Head Color:
G=Grey
N=Black
T=Transparent
A=CSA-UL Black
B=CSA-UL Grey

Cable Length in Meters (L):
A=1
B=1.5
C=2
D=2.5
E=3
F=3.5
G=4
H=4.5
L=5
M=5.5
N=6
P=6.5
Q=7
R=7.5
S=8
T=8.5
U=9
K=10

Cable Length in cm Between 2 Mouldings (L1)
Eg.: 15=15 cm
30=30 cm
1K=100 cm
min length=13 cm

Earth PIN Location:
1=Double Earth on 6H and 12H

Internal Circuit Wiring Configuration
Eg.: C4, 00, S0
See Sheet 1

Voltage and LED Color:

1= 12V 2= 24V 3= 48V 4= 115V 5= 230V	RED LED
A= 12V B= 24V C= 48V D= 115V E= 230V	GREEN LED
G= 12V H= 24V K= 48V L= 115V M= 230V	YELLOW LED

Type of Gasket and Screw:
1=NBR Profile Gasket + Fixing Screw (M3x25 mm)
2=NBR Flat Gasket + Fixing Screw (M3x25 mm)
3=Silicone Profile Gasket + Fixing Screw (M3x25 mm)
4=Silicone Flat Gasket + Fixing Screw (M3x25 mm)
P=Integrated Gasket Assembled + Fixing Screw with Washer Assembled (M3x27 mm)
R=Integrated Gasket + Fixing Screw + Washer (M3x27 mm)
T=Profile Gasket + Fixing Screw + Washer (M3x27 mm)

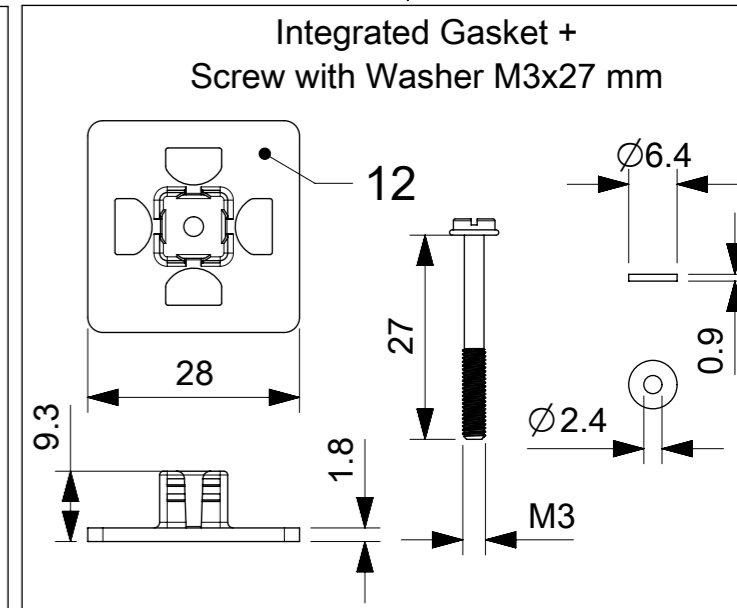
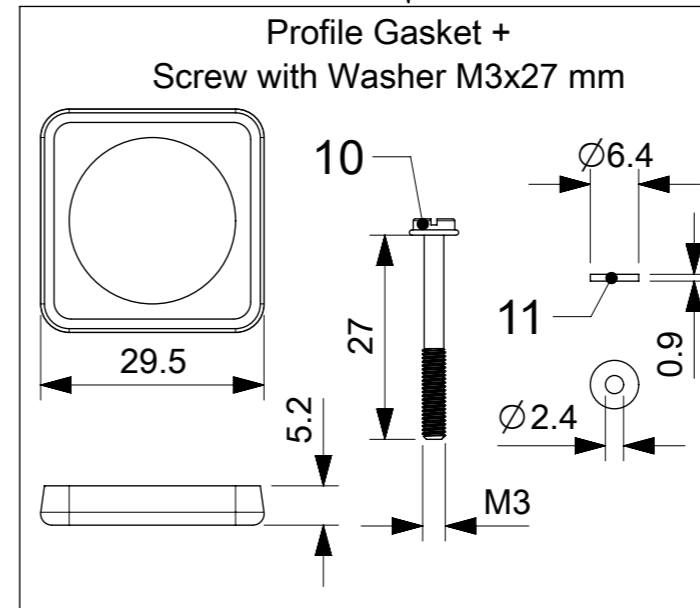
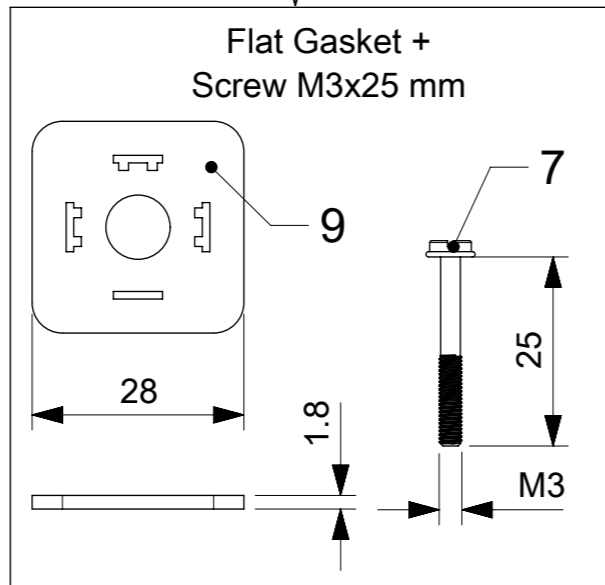
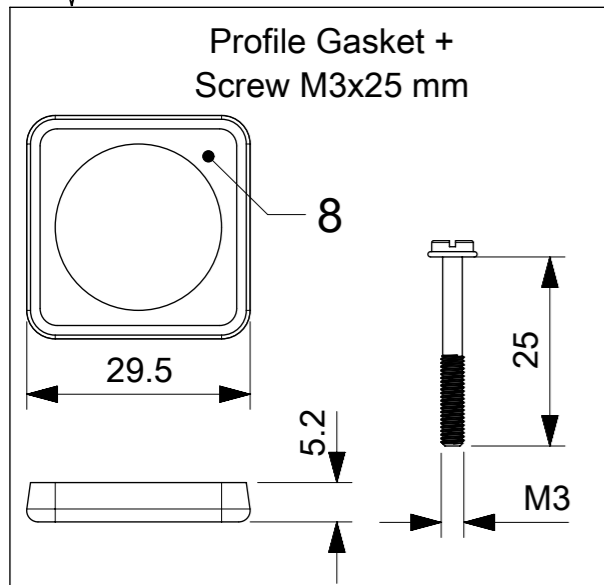

FUNCTIONAL SYMBOLS	THIS DRAWING CONTAINS INFORMATION THAT IS PROPRIETARY TO MOLEX ELECTRONIC TECHNOLOGIES, LLC AND SHOULD NOT BE USED WITHOUT WRITTEN PERMISSION	
△/A = 0	DIMENSION UNITS: mm	SCALE: 1:1
△/E = 0	GENERAL TOLERANCES (UNLESS SPECIFIED)	
△/F = 0	ANGULAR TOL ± 1.0°	
DIVISIONAL SYMBOLS	4 PLACES ±	3 PLACES ±
	2 PLACES ± 0.05	1 PLACE ± 0.3
	0 PLACES ± 0.5	
	DRAFT WHERE APPLICABLE MUST REMAIN WITHIN DIMENSIONS	THIRD ANGLE PROJECTION
	DRAWING: A3-SIZE	SERIES: 121055
	MATERIAL NUMBER: SEE SHEET 3	CUSTOMER: GENERAL MARKET
	EC NO: 642619	DRWN: SSM
	CHK'D: RSILLER	APPR: RSILLER
	INITIAL REVISION: DRWN: APAWLAK01	2020/07/20
	APPR: MIWASIECZKO	2020/09/04
	2017/07/03	2017/07/05
	DOCUMENT NUMBER: 1210550123	DOC TYPE: PSD
	DOC PART: 000	REVISION: A1
	SHEET NUMBER: 2 OF 3	

TABLE 1 - CABLES

Molex PN	mPm	Code	Wires	Cross Section	Material	Colour	Diameter \varnothing
1210180080	I	0	3	1 mm ²	PVC CEI 2022 II O.R.	Grey RAL7035	6.4±0.2 mm
1210180467	A	2	2	20 AWG	PVC CSA/UL 2661	Black	5.4±0.2 mm
1210180128	A	2	3	20 AWG	PVC CSA/UL 2661	Black	5.6±0.2 mm
1210180394	A	2	4	20 AWG	PVC CSA/UL 2661	Black	6.2±0.25 mm
-	A	2	5	20 AWG	PVC CSA/UL 2661	Black	7±0.2 mm
1210180297	B	2	2	20 AWG	PUR CSA/UL 20668	Black	5.6±0.2 mm
1210180126	B	2	3	20 AWG	PUR CSA/UL 20668	Black	5.6±0.2 mm
1210180387	B	2	4	20 AWG	PUR CSA/UL 20668	Black	6.2±0.2 mm
-	B	2	5	20 AWG	PUR CSA/UL 20668	Black	7±0.2 mm
1210180122	D	2	3	0.5 mm ²	PVC TI2 CEI 20-20	Grey	5.5±0.2 mm
-	F	2	3	0.5 mm ²	CNEOMO	Grey RAL7000	5.5±0.2 mm
1210180047	I	2	2	0.5 mm ²	PVC CEI 2022 II O.R.	Grey RAL7035	5.5+0.3/-0 mm
1210180284	I	2	3	0.5 mm ²	PVC CEI 2022 II O.R.	Grey RAL7035	5.5+0.3/-0 mm
1210180146	I	2	4	0.5 mm ²	PVC CEI 2022 II O.R.	Grey RAL7035	6.5±0.2 mm
1210180177	I	2	5	0.5 mm ²	PVC CEI 2022 II O.R.	Grey RAL7035	7±0.2 mm
1210180022	N	2	2	0.5 mm ²	PVCH03	Black	5.2±0.2 mm
1202092753	N	2	3	0.5 mm ²	PVCH03	Black	5.5±0.2 mm
1210180153	N	2	4	0.5 mm ²	PVCH03	Black	6.9 mm max
1210180046	P	2	2	0.5 mm ²	PUR-BLEND	Black	5.5±0.2 mm
1202092439	P	2	3	0.5 mm ²	PUR-BLEND	Black	5.5+0.3/-0 mm
1210180302	P	2	4	0.5 mm ²	PUR-BLEND	Black	6.5±0.2 mm
1202092215	P	2	5	0.5 mm ²	PUR-BLEND	Black	7+0.3/-0.1 mm
1210180409	A	3	2	18 AWG	PVC CSA/UL 2661	Black	6.5±0.25 mm
1210180129	A	3	3	18 AWG	PVC CSA/UL 2661	Black	6.5±0.25 mm
1210180159	A	3	4	18 AWG	PVC CSA/UL 2661	Black	7±0.3 mm
1210180464	A	3	5	18 AWG	PVC CSA/UL 2661	Black	7.8±0.25 mm
1210180351	B	3	2	18 AWG	PUR CSA/UL 20668	Black	6.8±0.2 mm
1210180127	B	3	3	18 AWG	PUR CSA/UL 20668	Black	6.5±0.2 mm
1210180160	B	3	4	18 AWG	PUR CSA/UL 20668	Black	7±0.2 mm
1210180463	B	3	5	18 AWG	PUR CSA/UL 20668	Black	7.8±0.2 mm
1210180073	D	3	3	0.75 mm ²	PVC TI2 CEI 20-20	Grey	6.5±0.2 mm
1210180145	D	3	4	0.75 mm ²	PVC TI2 CEI 20-20	Grey	7.1±0.2 mm
1202098206	I	3	2	0.75 mm ²	PVC CEI 2022 II O.R.	Grey RAL7001	5.5±0.2 mm
1210180120	I	3	3	0.75 mm ²	PVC CEI 2022 II O.R.	Grey RAL7035	6±0.2 mm
1210180143	I	3	4	0.75 mm ²	PVC CEI 2022 II O.R.	Grey RAL7035	7±0.2 mm
1210180032	N	3	2	0.75 mm ²	PVCH05	Black	6.2±0.2 mm
1210180069	N	3	3	0.75 mm ²	PVCH05	Black	6.5±0.2 mm
1210180144	N	3	4	0.75 mm ²	PVCH05	Black	7.1±0.2 mm
1210180174	N	3	5	0.75 mm ²	PVCH05	Black	8.0+0.2/-0 mm
1202094190	P	3	2	0.75 mm ²	PUR-BLEND	Black	6.5±0.2 mm
1210180071	P	3	3	0.75 mm ²	PUR-BLEND	Black	6.5±0.2 mm
1210180152	P	3	4	0.75 mm ²	PUR-BLEND	Black	7±0.2 mm
1210180384	R	3	3	0.75 mm ²	TPR HAL. FREE	Black	6.5±0.2 mm
1210180094	T	3	3	0.75 mm ²	PUR CSA/UL	Yellow	6.5±0.2 mm
1210180309	Y	3	3	0.75 mm ²	SIL/0300	Red	6.5±0.2 mm
1210180081	F	4	3	1 mm ²	CNEOMO	Grey RAL7000	7.1+0.2/-0 mm
-	F	4	4	1 mm ²	CNEOMO	Grey RAL7000	7.1+0.2/-0 mm
1210180042	I	4	2	1 mm ²	PVC CEI 2022 II O.R.	Grey RAL7035	7.1+0.2/-0 mm
1210180079	I	4	3	1 mm ²	PVC CEI 2022 II O.R.	Grey RAL7035	7.1+0.2/-0 mm
1210180036	N	4	2	1 mm ²	PVCH05	Black	6.5±0.2 mm
1210180082	N	4	3	1 mm ²	PVCH05	Black	6.9±0.2 mm
1210180117	R	4	3	1 mm ²	TPR HAL. FREE	Black	7.1±0.2 mm
1210180085	N	5	3	1.5 mm ²	PVCH05	Black	8.3+0.2/-0 mm
1210180313	I	6	2	0.35 mm ²	PVC CEI 2022 II O.R.	Grey RAL7035	4.8±0.2 mm
-	A	7	3	20 AWG	PVC CSA/UL 2661	Yellow	5.6±0.2 mm
1210180149	I	9	4	0.75 mm ²	PVC CEI 2022 II O.R.	Grey RAL7035	7.3±0.2 mm

TABLE 2 - PART LIST

MOLEX PN	ENGINEERING PN
1210550123	E652N3NC3011C3B
1210550139	E652N2NL1511S02
1210550160	E652N2NL151PS02
1210550206	E652N3NE1611C42
1210550207	E652N3NE1611C41
1210550254	E652P2NP1321C4H
1210550276	E652N2NL1611C4H
1210550278	E652N3NB3511000
1210550279	E652N3NL1611C4H
1210550281	E652P3NA1311A11
1210550297	E652N3NC1611000
1210550304	E652N2NE201PS02
1210550316	E652N2NE251PS02
1210550335	E652P3NA131PS0G
1210550336	E652P3NA151PS0G
1210550348	E652N2NE151PS02

FUNCTIONAL SYMBOLS	THIS DRAWING CONTAINS INFORMATION THAT IS PROPRIETARY TO MOLEX ELECTRONIC TECHNOLOGIES, LLC AND SHOULD NOT BE USED WITHOUT WRITTEN PERMISSION		CURRENT REV DESC: TOL. TABLE UPDATED	
	DIMENSION UNITS	SCALE		
$\nabla_A = 0$	mm	1:1		
$\nabla_E = 0$	GENERAL TOLERANCES (UNLESS SPECIFIED)			
$\nabla_P = 0$	ANGULAR TOL ± 1.0°			
DIVISIONAL SYMBOLS	4 PLACES	±		
	3 PLACES	±		
	2 PLACES	± 0.05		
	1 PLACE	± 0.3		
	0 PLACES	± 0.5		
DRAFT WHERE APPLICABLE MUST REMAIN WITHIN DIMENSIONS		THIRD ANGLE PROJECTION	DRAWING	SERIES
			A3-SIZE	121055
DOCUMENT STATUS		DOC TYPE	DOC PART	REVISION
P1	RELEASE DATE	2020/09/04	13:21:28	
MOLEX		STANDARD E652 DIN FORM A DUAL		
PRODUCT CUSTOMER DRAWING		EC NO: 642619	DRWN: SSM	2020/07/20
		CHK'D: RSILLER	APPR: RSILLER	2020/09/04
INITIAL REVISION:		DRWN: APAWLAK01	APPR: MIWASIECZKO	2017/07/03
DOCUMENT NUMBER		1210550123	PSD	000
CUSTOMER		GENERAL MARKET	SHEET NUMBER	
				3 OF 3

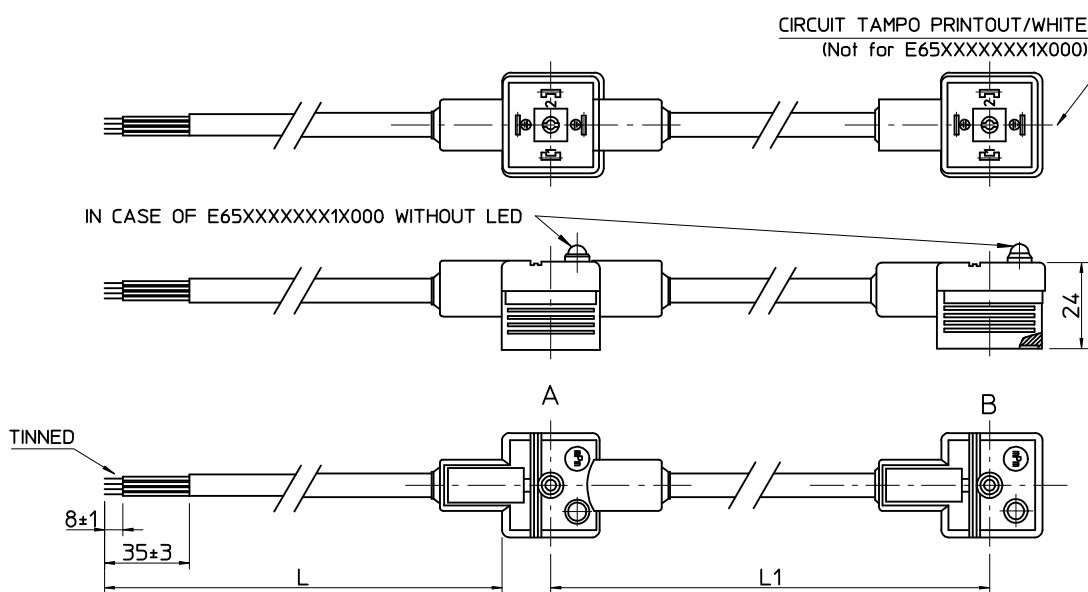
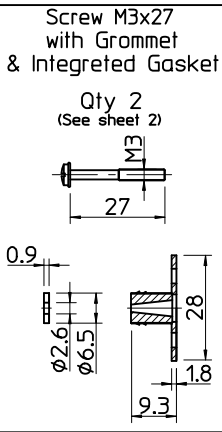
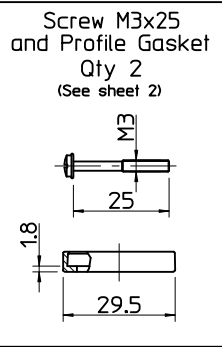
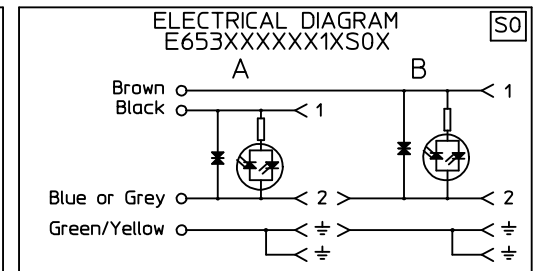
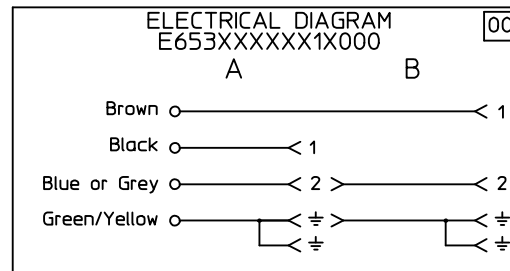
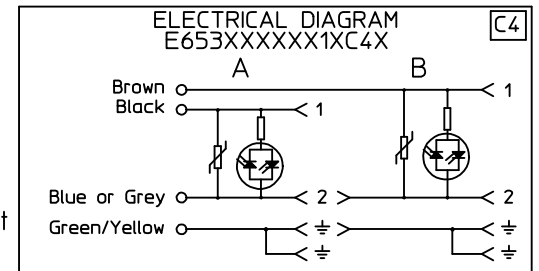
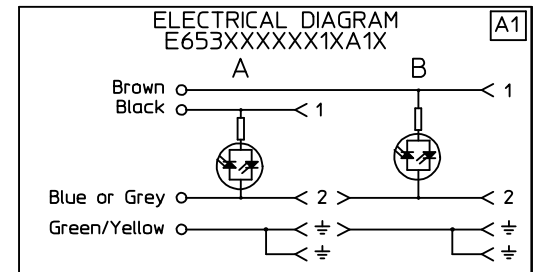
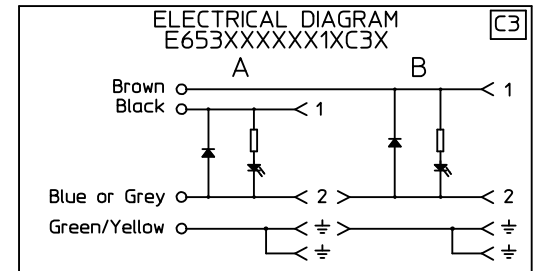

Table of length tolerances [mm]

Over	Up to and including	Tolerance
0	1000	±20
1000	3000	±30
3000	5000	±40
5000	10000	±50
10000	15000	±100
15000	20000	±150
20000		±L/100

NOTE: Ground on schematics does not apply to E652XXXXXXXX1XXXX



<p>DRAWING UPDATE EC NO: IPG2013-1505 DRWIN: JMARSZALEK 2013/03/28 CHKD: MIWASIECZKO APPR: MIWASIECZKO 2013/04/02</p>	<p>QUALITY SYMBOLS ▽=0 ◻=0</p>	<p>GENERAL TOLERANCES (UNLESS SPECIFIED)</p>		<p>DIMENSION STYLE MM ONLY</p>		SCALE	DESIGN UNITS	<p>FIRST ANGLE PROJECTION</p>																				
							METRIC																					
		<table border="1"> <thead> <tr> <th></th> <th>mm</th> <th>INCH</th> </tr> </thead> <tbody> <tr> <td>4 PLACES</td> <td>± ---</td> <td>± ---</td> </tr> <tr> <td>3 PLACES</td> <td>± ---</td> <td>± ---</td> </tr> <tr> <td>2 PLACES</td> <td>± ---</td> <td>± ---</td> </tr> <tr> <td>1 PLACE</td> <td>± ---</td> <td>± ---</td> </tr> <tr> <td>0 PLACE</td> <td>± ---</td> <td>± ---</td> </tr> </tbody> </table>			mm	INCH	4 PLACES		± ---	± ---	3 PLACES	± ---	± ---	2 PLACES	± ---	± ---	1 PLACE	± ---	± ---	0 PLACE	± ---	± ---	<p>DRAWN BY: JMARSZALEK 2013/01/16 CHECKED BY: MSZWAJKOWSKI 2013/01/16 APPROVED BY: MIWASIECZKO 2013/02/12</p>		TITLE		E65XXXXXXXX1XXXX DUAL DIN FORM A	
			mm	INCH																								
4 PLACES	± ---	± ---																										
3 PLACES	± ---	± ---																										
2 PLACES	± ---	± ---																										
1 PLACE	± ---	± ---																										
0 PLACE	± ---	± ---																										
<p>DRAFT WHERE APPLICABLE MUST REMAIN WITHIN DIMENSIONS</p>		<p>ANGULAR ± --- °</p>		<p>MATERIAL NO. SEE SHEET 2&3</p>		<p>DOCUMENT NO. SD-121055-001</p>		<p>SHEET NO. 1 OF 4</p>																				

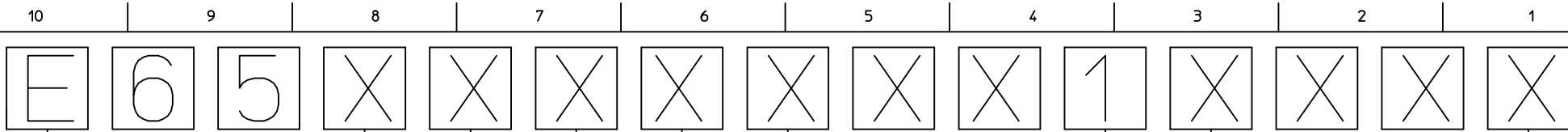

E - Packing without bags
W - Single packing
0 - Quick packing

NUMBER OF WIRES:
2=2 POLES
3=2 POLES+GROUND

CABLE TYPE
SEE TABLE 1

CABLE CROSS SECTION AREA
SEE TABLE 2

HEAD COLOUR:

G=GREY
N=BLACK
T=TRANSPARENT
A=CSA-UL BLACK
B=CSA-UL GREY

CABLE LENGTH IN CM BETWEN 2 MOULDINGS (L1)
Eg.:050=50 CM, 300=300 CM, 10K=1000 CM

EARTH PIN LOCATION:

1=DOUBLE EARTH ON 6H AND 12H,

TYPE OF GASKET AND SCREW:

- 1=NBR PROFILE GASKET + FIXING SCREWS (M3x25 mm).
- 2=NBR FLAT GASKET + FIXING SCREW (M3x25 mm).
- 3=SILICONE PROFILE GASKET + FIXING SCREW (M3x25 mm).
- 4=SILICON FLAT GASKET + FIXING SCREW (M3x25 mm).
- P=INTEGRATED GASKET ASSEMBLED + FIXING SCREW WITH GROMMET ASSEMBLED (M3x27 mm).
- R=INTAGRATED GASKET + FIXING SCREW + GROMMET (M3x27 mm).
- T=PROFILE GASKET + FIXING SCREW + GROMMET (M3x27 mm).

INTERNAL CIRCUIT

WIRING CONFIGURATION

VOLTAGE AND LED COLOUR:

1= 12V	A= 12V	G= 12V
2= 24V	B= 24V	H= 24V
3= 48V	C= 48V	K= 48V
4= 115V	D= 115V	L= 115V
5= 230V	E= 230V	M= 230V

RED LED GREEN LED YELLOW LED

CABLE LENGHT IN METERS (L)

A=1
B=1,5
C=2
D=2,5
E=3
F=3,5
G=4
H=4,5
L=5
M=5,5
N=6
P=6,5
O=7
R=7,5
S=8
T=8,5
U=9
K=10

DRAWING UPDATE EC NO: IPG2013-1505 DRWN: JMARSZALEK 2013/03/28 CHKD: APPR: MIWASIECZKO 2013/04/02	QUALITY SYMBOLS	GENERAL TOLERANCES (UNLESS SPECIFIED)	DIMENSION STYLE MM ONLY	SCALE 1:1	DESIGN UNITS METRIC	FIRST ANGLE PROJECTION																																					
	 	<table border="1"> <thead> <tr> <th></th> <th>mm</th> <th>INCH</th> </tr> </thead> <tbody> <tr> <td>4 PLACES</td> <td>± ---</td> <td>± ---</td> </tr> <tr> <td>3 PLACES</td> <td>± ---</td> <td>± ---</td> </tr> <tr> <td>2 PLACES</td> <td>± ---</td> <td>± ---</td> </tr> <tr> <td>1 PLACE</td> <td>± ---</td> <td>± ---</td> </tr> <tr> <td>0 PLACE</td> <td>± ---</td> <td>± ---</td> </tr> </tbody> </table>		mm	INCH	4 PLACES	± ---	± ---	3 PLACES	± ---	± ---	2 PLACES	± ---	± ---	1 PLACE	± ---	± ---	0 PLACE	± ---	± ---	<table border="1"> <thead> <tr> <th colspan="2">DRAWN BY</th> <th>DATE</th> </tr> </thead> <tbody> <tr> <td>JMARSZALEK</td> <td></td> <td>2013/01/16</td> </tr> <tr> <th colspan="2">CHECKED BY</th> <th>DATE</th> </tr> <tr> <td>MSZWAJKOWSKI</td> <td></td> <td>2013/01/16</td> </tr> <tr> <th colspan="2">APPROVED BY</th> <th>DATE</th> </tr> <tr> <td>MIWASIECZKO</td> <td></td> <td>2013/02/12</td> </tr> </tbody> </table>	DRAWN BY		DATE	JMARSZALEK		2013/01/16	CHECKED BY		DATE	MSZWAJKOWSKI		2013/01/16	APPROVED BY		DATE	MIWASIECZKO		2013/02/12	TITLE	E65XXXXXXXX1XXXX DUAL DIN FORM A		
		mm	INCH																																								
	4 PLACES	± ---	± ---																																								
	3 PLACES	± ---	± ---																																								
2 PLACES	± ---	± ---																																									
1 PLACE	± ---	± ---																																									
0 PLACE	± ---	± ---																																									
DRAWN BY		DATE																																									
JMARSZALEK		2013/01/16																																									
CHECKED BY		DATE																																									
MSZWAJKOWSKI		2013/01/16																																									
APPROVED BY		DATE																																									
MIWASIECZKO		2013/02/12																																									
DRAFT WHERE APPLICABLE MUST REMAIN WITHIN DIMENSIONS	MATERIAL NO. SEE SHEET 2&3	DOCUMENT NO. SD-121055-001																																									
	SIZE A3	THIS DRAWING CONTAINS INFORMATION THAT IS PROPRIETARY TO MOLEX INCORPORATED AND SHOULD NOT BE USED WITHOUT WRITTEN PERMISSION																																									

TABLE 2 - CABLES

Mollex PN	mPm	Code	Wires	Cross Section	Material	Color	Diameter Ø	DIN A-B	DIN C
1210180080	I	0	3	1 mm2	PVC CEI 2022 II O.R.	Grey RAL7035	6,4±0,2 mm	OK.	-
1210180467	A	2	2	20 AWG	PVC CSA/UL 2661	Black	5,4±0,2 mm	OK.	OK.
1210180128	A	2	3	20 AWG	PVC CSA/UL 2661	Black	5,6±0,2 mm	OK.	OK.
1210180394	A	2	4	20 AWG	PVC CSA/UL 2661	Black	6,2±0,25 mm	OK.	OK.
-	A	2	5	20 AWG	PVC CSA/UL 2661	Black	7±0,2 mm	OK.	-
1210180297	B	2	2	20 AWG	PUR CSA/UL 20668	Black	5,6±0,2 mm	OK.	OK.
1210180126	B	2	3	20 AWG	PUR CSA/UL 20668	Black	5,6±0,2 mm	OK.	OK.
1210180387	B	2	4	20 AWG	PUR CSA/UL 20668	Black	6,2±0,2 mm	OK.	OK.
-	B	2	5	20 AWG	PUR CSA/UL 20668	Black	7±0,2 mm	OK.	-
1210180122	D	2	3	0,5 mm2	PVC TI2 CEI 20-20	Grey	5,5±0,2 mm	OK.	OK.
-	F	2	3	0,5 mm2	CNOMO	Grey RAL7000	5,5±0,2 mm	OK.	OK.
1210180047	I	2	2	0,5 mm2	PVC CEI 2022 II O.R.	Grey RAL7035	5,5+0,3/-0 mm	OK.	OK.
1210180284	I	2	3	0,5 mm2	PVC CEI 2022 II O.R.	Grey RAL7035	5,6+0,3/-0 mm	OK.	OK.
1210180146	I	2	4	0,5 mm2	PVC CEI 2022 II O.R.	Grey RAL7035	6,5±0,2 mm	OK.	OK.
1210180177	I	2	5	0,5 mm2	PVC CEI 2022 II O.R.	Grey RAL7035	7±0,2 mm	OK.	-
1210180022	N	2	2	0,5 mm2	PVCH03	Black	5,2±0,2 mm	OK.	OK.
1202092753	N	2	3	0,5 mm2	PVCH03	Black	5,5±0,2 mm	OK.	OK.
1210180153	N	2	4	0,5 mm2	PVCH03	Black	6,9 mm max	OK.	OK.
1210180046	P	2	2	0,5 mm2	PUR - BLEND	Black	5,5±0,2 mm	OK.	OK.
1202092439	P	2	3	0,5 mm2	PUR - BLEND	Black	5,5 +0,3/-0 mm	OK.	OK.
1210180302	P	2	4	0,5 mm2	PUR - BLEND	Black	6,5±0,2 mm	OK.	OK.
1202092215	P	2	5	0,5 mm2	PUR - BLEND	Black	7+0,3/-0,1 mm	OK.	OK.
1210180409	A	3	2	18 AWG	PVC CSA/UL 2661	Black	6,5±0,25 mm	OK.	-
1210180129	A	3	3	18 AWG	PVC CSA/UL 2661	Black	6,5±0,25 mm	OK.	-
1210180159	A	3	4	18 AWG	PVC CSA/UL 2661	Black	7±0,3 mm	OK.	-
1210180464	A	3	5	18 AWG	PVC CSA/UL 2661	Black	7,8±0,25 mm	OK.	-
1210180351	B	3	2	18 AWG	PUR CSA/UL 20668	Black	6,8±0,2 mm	OK.	-
1210180127	B	3	3	18 AWG	PUR CSA/UL 20668	Black	6,5±0,2 mm	OK.	-
1210180160	B	3	4	18 AWG	PUR CSA/UL 20668	Black	7±0,2 mm	OK.	-
1210180463	B	3	5	18 AWG	PUR CSA/UL 20668	Black	7,8±0,2 mm	OK.	-
1210180073	D	3	3	0,75 mm2	PVC TI2 CEI 20-20	Grey	6,5±0,2 mm	OK.	OK.
1210180145	D	3	4	0,75 mm2	PVC TI2 CEI 20-20	Grey	7,1±0,2 mm	OK.	-
1202098206	I	3	2	0,75 mm2	PVC CEI 2022 II O.R.	Grey RAL7001	5,5±0,2 mm	OK.	-
1210180120	I	3	3	0,75 mm2	PVC CEI 2022 II O.R.	Grey RAL7035	6±0,2 mm	OK.	-
1210180143	I	3	4	0,75 mm2	PVC CEI 2022 II O.R.	Grey RAL7035	7±0,2 mm	OK.	-
1210180032	N	3	2	0,75 mm2	PVCH05	Black	6,2±0,2 mm	OK.	-
1210180069	N	3	3	0,75 mm2	PVCH05	Black	6,5±0,2 mm	OK.	-
1210180144	N	3	4	0,75 mm2	PVCH05	Black	7,1±0,2 mm	OK.	-
1210180174	N	3	5	0,75 mm2	PVCH05	Black	8,0+0,2-0 mm	OK.	-
1202094190	P	3	2	0,75 mm2	PUR - BLEND	Black	6,5±0,2 mm	OK.	-

TABLE 2 - CABLES

Mollex PN	mPm	Code	Wires	Cross Section	Material	Color	Diameter Ø	DIN A-B	DIN C
1210180071	P	3	3	0,75 mm2	PUR - BLEND	Black	6,5±0,2 mm	OK.	-
1210180152	P	3	4	0,75 mm2	PUR - BLEND	Black	7±0,2 mm	OK.	-
1210180384	R	3	3	0,75 mm2	TPR HAL. FREE	Black	6,5±0,2 mm	OK.	-
1210180094	T	3	3	0,75 mm2	PUR CSA/UL	Yellow	6,5±0,2 mm	OK.	-
1210180309	Y	3	3	0,75 mm2	SIL/0300	Red	6,5±0,2 mm	OK.	-
1210180081	F	4	3	1 mm2	CNOMO	Grey RAL7000	7,1+0,2/-0 mm	OK.	-
-	F	4	4	1 mm2	CNOMO	Grey RAL7000	7,1+0,2/-0 mm	OK.	-
1210180042	I	4	2	1 mm2	PVC CEI 2022 II O.R.	Grey RAL7035	7,1+0,2/-0 mm	OK.	-
1210180079	I	4	3	1 mm2	PVC CEI 2022 II O.R.	Grey RAL7035	7,1+0,2/-0 mm	OK.	-
1210180036	N	4	2	1 mm2	PVCH05	Black	6,5±0,2 mm	OK.	-
1210180082	N	4	3	1 mm2	PVCH05	Black	6,9±0,2 mm	OK.	-
1210180117	R	4	3	1 mm2	TPR HAL. FREE	Black	7,1±0,2 mm	OK.	-
1210180085	N	5	3	1,5 mm2	PVCH05	Black	8,3+0,2/-0 mm	OK.	-
1210180313	I	6	2	0,35 mm2	PVC CEI 2022 II O.R.	Grey RAL7035	4,8±0,2 mm	OK.	-
-	A	7	3	20 AWG	PVC CSA/UL 2661	Yellow	5,6±0,2 mm	OK.	OK.
1210180149	I	9	4	0,75 mm2	PVC CEI 2022 II O.R.	Grey RAL7035	7,3±0,2 mm	OK.	-



TABLE 1 - CABLES TYPE

Code	Cable types	Features	Stranding
N	PVC	Application general purpose cable which has good resistance to water, but usually poor oil resistance.	0,5 mm2 = 15 x 0,20 0,75 mm2 = 21 x 0,20 1 mm2 = 28 x 0,20
I	CEI	Approved to IEC 332-2A, flame retardant and self extinguishing. Limited resistant to mineral oils.	0,5 mm2 = 28 x 0,15 0,75 mm2 = 42 x 0,15 1 mm2 = 32 x 0,20
P	PUR	Offer good resistance to oil and chemicals. Can swell when constantly immersed in water.	0,5 mm2 = 28 x 0,15 0,75 mm2 = 42 x 0,15 1 mm2 = 32 x 0,20
A	PVC CSA-UL	Approved to CSA-UL 2661, application general purpose cable which has good resistance to water, but usually poor oil resistance.	20 AWG = 32 x 0,15 18 AWG = 52 x 0,15
B	PUR CSA-UL	Approved to CSA-UL 20668, very good resistance to oil and chemicals.	20 AWG = 32 x 0,15 18 AWG = 52 x 0,15

<p>DRAWING UPDATE EC NO: IPG2013-1505 DRWN: JMARSZALEK 2013/03/28 CHKD: APPR: MIWASIECZKO 2013/04/02</p>	<p>QUALITY SYMBOLS ▽=0 ◻=0</p>	GENERAL TOLERANCES (UNLESS SPECIFIED)		DIMENSION STYLE MM ONLY		SCALE 1:1	DESIGN UNITS METRIC	FIRST ANGLE PROJECTION		
		mm		INCH		DRAWN BY JMARSZALEK		DATE 2013/01/16		
		4 PLACES ± --- ± ---		3 PLACES ± --- ± ---		CHECKED BY MSZWAJKOWSKI		DATE 2013/01/16		<p>E65XXXXXXXX1XXXX DUAL DIN FORM A</p>
		2 PLACES ± --- ± ---		1 PLACE ± --- ± ---		APPROVED BY MIWASIECZKO		DATE 2013/02/12		
0 PLACE ± --- ± ---		ANGULAR ± --- °		DRAFT WHERE APPLICABLE MUST REMAIN WITHIN DIMENSIONS		SEE SHEET 2&3		DOCUMENT NO. SD-121055-001		
SHEET NO. 3 OF 4		THIS DRAWING CONTAINS INFORMATION THAT IS PROPRIETARY TO MOLEX INCORPORATED AND SHOULD NOT BE USED WITHOUT WRITTEN PERMISSION								

PART LIST

Molex PN:	Engineering No.:
1210550161	E653P3NA1311C4H
1210550292	E653P3NA1311C4M

DRAWING UPDATE EC NO: IPG2013-1505 DRWN: JMARSZALEK 2013/03/28 CHKD: APPR: MIWASIECZKO 2013/04/02 REV	QUALITY SYMBOLS  = 0  = 0 DESCRIPTION	GENERAL TOLERANCES (UNLESS SPECIFIED) <table border="1"> <tr> <td></td> <td>mm</td> <td>INCH</td> </tr> <tr> <td>4 PLACES</td> <td>± ---</td> <td>± ---</td> </tr> <tr> <td>3 PLACES</td> <td>± ---</td> <td>± ---</td> </tr> <tr> <td>2 PLACES</td> <td>± ---</td> <td>± ---</td> </tr> <tr> <td>1 PLACE</td> <td>± ---</td> <td>± ---</td> </tr> <tr> <td>0 PLACE</td> <td>± ---</td> <td>± ---</td> </tr> </table>		mm	INCH	4 PLACES	± ---	± ---	3 PLACES	± ---	± ---	2 PLACES	± ---	± ---	1 PLACE	± ---	± ---	0 PLACE	± ---	± ---	DIMENSION STYLE MM ONLY DRAWN BY: JMARSZALEK DATE: 2013/01/16 CHECKED BY: MSZWAJKOWSKI DATE: 2013/01/16 APPROVED BY: MIWASIECZKO DATE: 2013/02/12 MATERIAL NO.:	SCALE: 1:1 DESIGN UNITS: METRIC FIRST ANGLE PROJECTION	TITLE: E65XXXXXXXX1XXXX DUAL DIN FORM A
			mm	INCH																			
4 PLACES	± ---	± ---																					
3 PLACES	± ---	± ---																					
2 PLACES	± ---	± ---																					
1 PLACE	± ---	± ---																					
0 PLACE	± ---	± ---																					
DRAFT WHERE APPLICABLE MUST REMAIN WITHIN DIMENSIONS SEE SHEET 2&3 SIZE: A3 THIS DRAWING CONTAINS INFORMATION THAT IS PROPRIETARY TO MOLEX INCORPORATED AND SHOULD NOT BE USED WITHOUT WRITTEN PERMISSION	DOCUMENT NO.: SD-121055-001	SHEET NO.: 4 OF 4																					

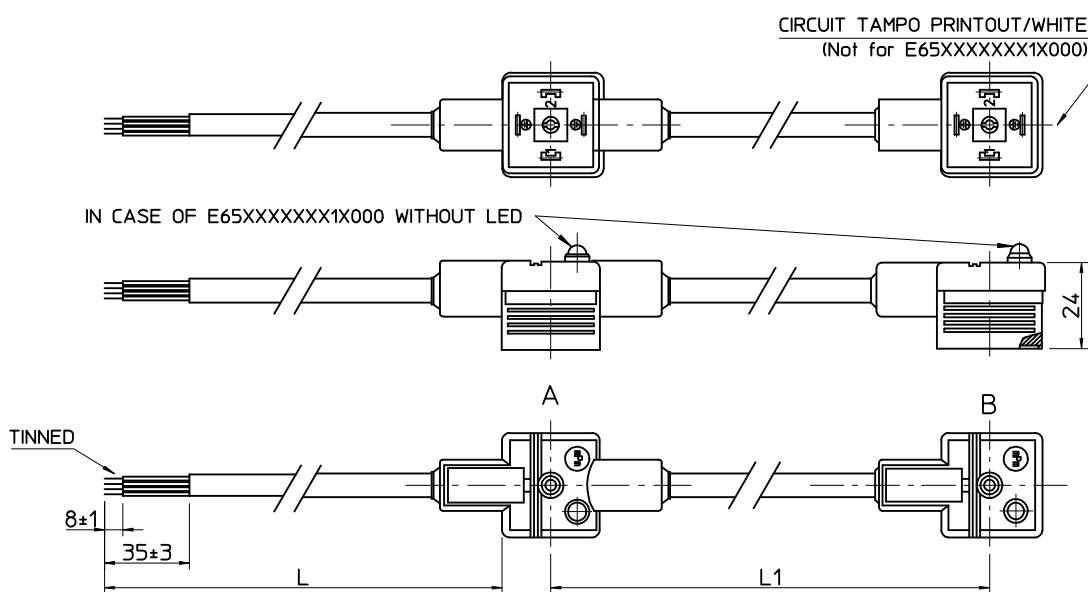
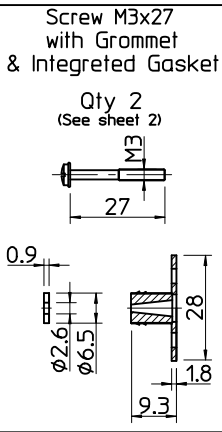
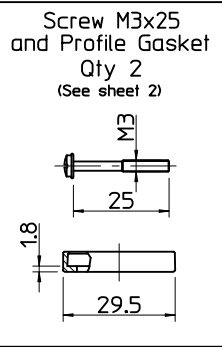
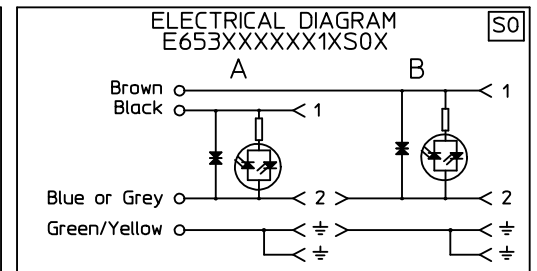
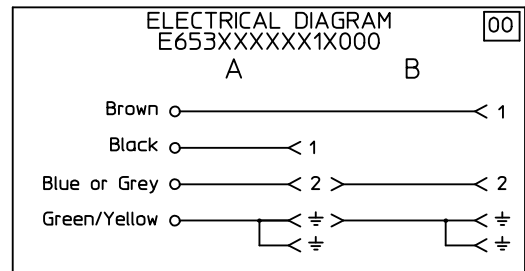
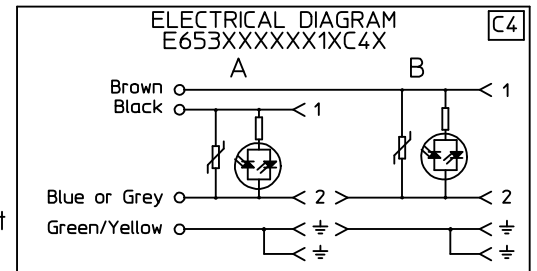
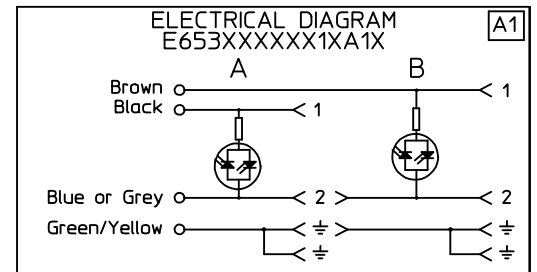
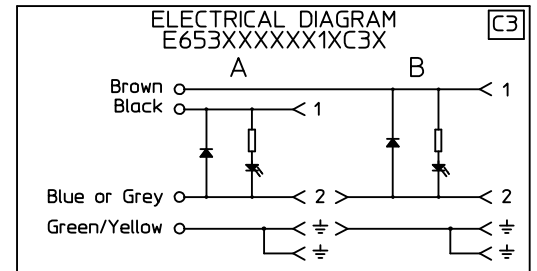

Table of length tolerances [mm]

Over	Up to and including	Tolerance
0	1000	±20
1000	3000	±30
3000	5000	±40
5000	10000	±50
10000	15000	±100
15000	20000	±150
20000		±L/100

NOTE: Ground on schematics does not apply to E652XXXXXX1XXXX



<p>DRAWING UPDATE EC NO: IPG2013-1505 DRWIN: JMARSZALEK 2013/03/28 CHKD: MIWASIECZKO APPR: MIWASIECZKO 2013/04/02</p>	<p>QUALITY SYMBOLS ▽=0 ◻=0</p>	<p>GENERAL TOLERANCES (UNLESS SPECIFIED)</p>		<p>DIMENSION STYLE MM ONLY</p>		SCALE	DESIGN UNITS	<p>FIRST ANGLE PROJECTION</p>
		mm	INCH	DRAWN BY	DATE	TITLE	<p>E65XXXXXX1XXXX DUAL DIN FORM A</p>	
		4 PLACES ± --- ± ---		JMARSZALEK	2013/01/16			
		3 PLACES ± --- ± ---		CHECKED BY	DATE			
2 PLACES ± --- ± ---		MSZWAJKOWSKI	2013/01/16					
1 PLACE ± --- ± ---		APPROVED BY	DATE					
0 PLACE ± --- ± ---		MIWASIECZKO	2013/02/12					
		ANGULAR ± --- °		MATERIAL NO.	DOCUMENT NO.	<p>molex</p>		
DRAFT WHERE APPLICABLE MUST REMAIN WITHIN DIMENSIONS		SEE SHEET 2&3		SD-121055-001		SHEET NO.		
				THIS DRAWING CONTAINS INFORMATION THAT IS PROPRIETARY TO MOLEX INCORPORATED AND SHOULD NOT BE USED WITHOUT WRITTEN PERMISSION		1 OF 4		

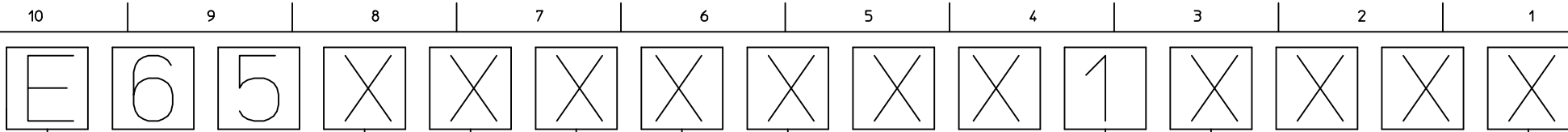

E - Packing without bags
 W - Single packing
 Q - Quick packing

NUMBER OF WIRES:
 2=2 POLES
 3=2 POLES+GROUND

CABLE TYPE
 SEE TABLE 1

CABLE CROSS SECTION AREA
 SEE TABLE 2

HEAD COLOUR:

G=GREY
 N=BLACK
 T=TRANSPARENT
 A=CSA-UL BLACK
 B=CSA-UL GREY

CABLE LENGTH IN CM BETWEN 2 MOULDINGS (L1)
 Eg.:050=50 CM, 300=300 CM, 10K=1000 CM

EARTH PIN LOCATION:

1=DOUBLE EARTH ON 6H AND 12H,

TYPE OF GASKET AND SCREW:

1=NBR PROFILE GASKET + FIXING SCREWS (M3x25 mm).
 2=NBR FLAT GASKET + FIXING SCREW (M3x25 mm).
 3=SILICONE PROFILE GASKET + FIXING SCREW (M3x25 mm).
 4=SILICON FLAT GASKET + FIXING SCREW (M3x25 mm).
 P=INTEGRATED GASKET ASSEMBLED + FIXING SCREW WITH GROMMET ASSEMBLED (M3x27 mm).
 R=INTAGRATED GASKET + FIXING SCREW + GROMMET (M3x27 mm).
 T=PROFILE GASKET + FIXING SCREW + GROMMET (M3x27 mm).

INTERNAL CIRCUIT

WIRING CONFIGURATION

VOLTAGE AND LED COLOUR:

1= 12V	A= 12V	G= 12V
2= 24V	B= 24V	H= 24V
3= 48V	C= 48V	K= 48V
4= 115V	D= 115V	L= 115V
5= 230V	E= 230V	M= 230V

RED LED GREEN LED YELLOW LED

CABLE LENGHT IN METERS (L)

A=1
 B=1,5
 C=2
 D=2,5
 E=3
 F=3,5
 G=4
 H=4,5
 L=5
 M=5,5
 N=6
 P=6,5
 Q=7
 R=7,5
 S=8
 T=8,5
 U=9
 K=10

DRAWING UPDATE EC NO: IPG2013-1505 DRWN: JMARSZALEK 2013/03/28 CHKD: APPR: MIWASIECZKO 2013/04/02	QUALITY SYMBOLS	GENERAL TOLERANCES (UNLESS SPECIFIED)	DIMENSION STYLE MM ONLY	SCALE 1:1	DESIGN UNITS METRIC	FIRST ANGLE PROJECTION																																					
	=0 =0	<table border="1"> <thead> <tr> <th></th> <th>mm</th> <th>INCH</th> </tr> </thead> <tbody> <tr> <td>4 PLACES</td> <td>± ---</td> <td>± ---</td> </tr> <tr> <td>3 PLACES</td> <td>± ---</td> <td>± ---</td> </tr> <tr> <td>2 PLACES</td> <td>± ---</td> <td>± ---</td> </tr> <tr> <td>1 PLACE</td> <td>± ---</td> <td>± ---</td> </tr> <tr> <td>0 PLACE</td> <td>± ---</td> <td>± ---</td> </tr> </tbody> </table>		mm	INCH	4 PLACES	± ---	± ---	3 PLACES	± ---	± ---	2 PLACES	± ---	± ---	1 PLACE	± ---	± ---	0 PLACE	± ---	± ---	<table border="1"> <thead> <tr> <th colspan="2">DRAWN BY</th> <th>DATE</th> </tr> </thead> <tbody> <tr> <td colspan="2">JMARSZALEK</td> <td>2013/01/16</td> </tr> <tr> <th colspan="2">CHECKED BY</th> <th>DATE</th> </tr> <tr> <td colspan="2">MSZWAJKOWSKI</td> <td>2013/01/16</td> </tr> <tr> <th colspan="2">APPROVED BY</th> <th>DATE</th> </tr> <tr> <td colspan="2">MIWASIECZKO</td> <td>2013/02/12</td> </tr> </tbody> </table>	DRAWN BY		DATE	JMARSZALEK		2013/01/16	CHECKED BY		DATE	MSZWAJKOWSKI		2013/01/16	APPROVED BY		DATE	MIWASIECZKO		2013/02/12	TITLE	E65XXXXXXXX1XXXX DUAL DIN FORM A		
		mm	INCH																																								
	4 PLACES	± ---	± ---																																								
	3 PLACES	± ---	± ---																																								
2 PLACES	± ---	± ---																																									
1 PLACE	± ---	± ---																																									
0 PLACE	± ---	± ---																																									
DRAWN BY		DATE																																									
JMARSZALEK		2013/01/16																																									
CHECKED BY		DATE																																									
MSZWAJKOWSKI		2013/01/16																																									
APPROVED BY		DATE																																									
MIWASIECZKO		2013/02/12																																									
DRAFT WHERE APPLICABLE MUST REMAIN WITHIN DIMENSIONS	MATERIAL NO. SEE SHEET 2&3	DOCUMENT NO. SD-121055-001																																									
	SIZE A3	THIS DRAWING CONTAINS INFORMATION THAT IS PROPRIETARY TO MOLEX INCORPORATED AND SHOULD NOT BE USED WITHOUT WRITTEN PERMISSION																																									

Mollex PN	mPm	Code	Wires	Cross Section	Material	Color	Diameter Ø	DIN A-B	DIN C
1210180080	I	0	3	1 mm2	PVC CEI 2022 II O.R.	Grey RAL7035	6,4±0,2 mm	OK.	-
1210180467	A	2	2	20 AWG	PVC CSA/UL 2661	Black	5,4±0,2 mm	OK.	OK.
1210180128	A	2	3	20 AWG	PVC CSA/UL 2661	Black	5,6±0,2 mm	OK.	OK.
1210180394	A	2	4	20 AWG	PVC CSA/UL 2661	Black	6,2±0,25 mm	OK.	OK.
-	A	2	5	20 AWG	PVC CSA/UL 2661	Black	7±0,2 mm	OK.	-
1210180297	B	2	2	20 AWG	PUR CSA/UL 20668	Black	5,6±0,2 mm	OK.	OK.
1210180126	B	2	3	20 AWG	PUR CSA/UL 20668	Black	5,6±0,2 mm	OK.	OK.
1210180387	B	2	4	20 AWG	PUR CSA/UL 20668	Black	6,2±0,2 mm	OK.	OK.
-	B	2	5	20 AWG	PUR CSA/UL 20668	Black	7±0,2 mm	OK.	-
1210180122	D	2	3	0,5 mm2	PVC TI2 CEI 20-20	Grey	5,5±0,2 mm	OK.	OK.
-	F	2	3	0,5 mm2	CNOMO	Grey RAL7000	5,5±0,2 mm	OK.	OK.
1210180047	I	2	2	0,5 mm2	PVC CEI 2022 II O.R.	Grey RAL7035	5,5+0,3/-0 mm	OK.	OK.
1210180284	I	2	3	0,5 mm2	PVC CEI 2022 II O.R.	Grey RAL7035	5,6+0,3/-0 mm	OK.	OK.
1210180146	I	2	4	0,5 mm2	PVC CEI 2022 II O.R.	Grey RAL7035	6,5±0,2 mm	OK.	OK.
1210180177	I	2	5	0,5 mm2	PVC CEI 2022 II O.R.	Grey RAL7035	7±0,2 mm	OK.	-
1210180022	N	2	2	0,5 mm2	PVCH03	Black	5,2±0,2 mm	OK.	OK.
1202092753	N	2	3	0,5 mm2	PVCH03	Black	5,5±0,2 mm	OK.	OK.
1210180153	N	2	4	0,5 mm2	PVCH03	Black	6,9 mm max	OK.	OK.
1210180046	P	2	2	0,5 mm2	PUR - BLEND	Black	5,5±0,2 mm	OK.	OK.
1202092439	P	2	3	0,5 mm2	PUR - BLEND	Black	5,5 +0,3/-0 mm	OK.	OK.
1210180302	P	2	4	0,5 mm2	PUR - BLEND	Black	6,5±0,2 mm	OK.	OK.
1202092215	P	2	5	0,5 mm2	PUR - BLEND	Black	7+0,3/-0,1 mm	OK.	OK.
1210180409	A	3	2	18 AWG	PVC CSA/UL 2661	Black	6,5±0,25 mm	OK.	-
1210180129	A	3	3	18 AWG	PVC CSA/UL 2661	Black	6,5±0,25 mm	OK.	-
1210180159	A	3	4	18 AWG	PVC CSA/UL 2661	Black	7±0,3 mm	OK.	-
1210180464	A	3	5	18 AWG	PVC CSA/UL 2661	Black	7,8±0,25 mm	OK.	-
1210180351	B	3	2	18 AWG	PUR CSA/UL 20668	Black	6,8±0,2 mm	OK.	-
1210180127	B	3	3	18 AWG	PUR CSA/UL 20668	Black	6,5±0,2 mm	OK.	-
1210180160	B	3	4	18 AWG	PUR CSA/UL 20668	Black	7±0,2 mm	OK.	-
1210180463	B	3	5	18 AWG	PUR CSA/UL 20668	Black	7,8±0,2 mm	OK.	-
1210180073	D	3	3	0,75 mm2	PVC TI2 CEI 20-20	Grey	6,5±0,2 mm	OK.	OK.
1210180145	D	3	4	0,75 mm2	PVC TI2 CEI 20-20	Grey	7,1±0,2 mm	OK.	-
1202098206	I	3	2	0,75 mm2	PVC CEI 2022 II O.R.	Grey RAL7001	5,5±0,2 mm	OK.	-
1210180120	I	3	3	0,75 mm2	PVC CEI 2022 II O.R.	Grey RAL7035	6±0,2 mm	OK.	-
1210180143	I	3	4	0,75 mm2	PVC CEI 2022 II O.R.	Grey RAL7035	7±0,2 mm	OK.	-
1210180032	N	3	2	0,75 mm2	PVCH05	Black	6,2±0,2 mm	OK.	-
1210180069	N	3	3	0,75 mm2	PVCH05	Black	6,5±0,2 mm	OK.	-
1210180144	N	3	4	0,75 mm2	PVCH05	Black	7,1±0,2 mm	OK.	-
1210180174	N	3	5	0,75 mm2	PVCH05	Black	8,0+0,2-0 mm	OK.	-
1202094190	P	3	2	0,75 mm2	PUR - BLEND	Black	6,5±0,2 mm	OK.	-

Mollex PN	mPm	Code	Wires	Cross Section	Material	Color	Diameter Ø	DIN A-B	DIN C
1210180071	P	3	3	0,75 mm2	PUR - BLEND	Black	6,5±0,2 mm	OK.	-
1210180152	P	3	4	0,75 mm2	PUR - BLEND	Black	7±0,2 mm	OK.	-
1210180384	R	3	3	0,75 mm2	TPR HAL. FREE	Black	6,5±0,2 mm	OK.	-
1210180094	T	3	3	0,75 mm2	PUR CSA/UL	Yellow	6,5±0,2 mm	OK.	-
1210180309	Y	3	3	0,75 mm2	SIL/0300	Red	6,5±0,2 mm	OK.	-
1210180081	F	4	3	1 mm2	CNOMO	Grey RAL7000	7,1+0,2/-0 mm	OK.	-
-	F	4	4	1 mm2	CNOMO	Grey RAL7000	7,1+0,2/-0 mm	OK.	-
1210180042	I	4	2	1 mm2	PVC CEI 2022 II O.R.	Grey RAL7035	7,1+0,2/-0 mm	OK.	-
1210180079	I	4	3	1 mm2	PVC CEI 2022 II O.R.	Grey RAL7035	7,1+0,2/-0 mm	OK.	-
1210180036	N	4	2	1 mm2	PVCH05	Black	6,5±0,2 mm	OK.	-
1210180082	N	4	3	1 mm2	PVCH05	Black	6,9±0,2 mm	OK.	-
1210180117	R	4	3	1 mm2	TPR HAL. FREE	Black	7,1±0,2 mm	OK.	-
1210180085	N	5	3	1,5 mm2	PVCH05	Black	8,3+0,2/-0 mm	OK.	-
1210180313	I	6	2	0,35 mm2	PVC CEI 2022 II O.R.	Grey RAL7035	4,8±0,2 mm	OK.	-
-	A	7	3	20 AWG	PVC CSA/UL 2661	Yellow	5,6±0,2 mm	OK.	OK.
1210180149	I	9	4	0,75 mm2	PVC CEI 2022 II O.R.	Grey RAL7035	7,3±0,2 mm	OK.	-

TABLE 1 - CABLES TYPE

Code	Cable types	Features	Stranding
N	PVC	Application general purpose cable which has good resistance to water, but usually poor oil resistance.	0,5 mm2 = 15 x 0,20 0,75 mm2 = 21 x 0,20 1 mm2 = 28 x 0,20
I	CEI	Approved to IEC 332-2A, flame retardant and self extinguishing. Limited resistant to mineral oils.	0,5 mm2 = 28 x 0,15 0,75 mm2 = 42 x 0,15 1 mm2 = 32 x 0,20
P	PUR	Offer good resistance to oil and chemicals. Can swell when constantly immersed in water.	0,5 mm2 = 28 x 0,15 0,75 mm2 = 42 x 0,15 1 mm2 = 32 x 0,20
A	PVC CSA-UL	Approved to CSA-UL 2661, application general purpose cable which has good resistance to water, but usually poor oil resistance.	20 AWG = 32 x 0,15 18 AWG = 52 x 0,15
B	PUR CSA-UL	Approved to CSA-UL 20668, very good resistance to oil and chemicals.	20 AWG = 32 x 0,15 18 AWG = 52 x 0,15

DRAWING UPDATE
EC NO: IPG2013-1505
DRWN: JMARSZALEK 2013/03/28
CHKD:
APPR: MIWASIECZKO 2013/04/02

QUALITY SYMBOLS
▽=0
◁=0

GENERAL TOLERANCES (UNLESS SPECIFIED)

	mm	INCH
4 PLACES	± ---	± ---
3 PLACES	± ---	± ---
2 PLACES	± ---	± ---
1 PLACE	± ---	± ---
0 PLACE	± ---	± ---

ANGULAR ± --- °
DRAFT WHERE APPLICABLE MUST REMAIN WITHIN DIMENSIONS

DIMENSION STYLE
MM ONLY

DRAWN BY	DATE
JMARSZALEK	2013/01/16
CHECKED BY	DATE
MSZWAJKOWSKI	2013/01/16
APPROVED BY	DATE
MIWASIECZKO	2013/02/12

MATERIAL NO.
SEE SHEET 2&3

SCALE
1:1

TITLE
E65XXXXXXXX1XXXX
DUAL DIN FORM A

DESIGN UNITS
METRIC

FIRST ANGLE PROJECTION

molex

DOCUMENT NO.
SD-121055-001

SHEET NO.
3 OF 4

THIS DRAWING CONTAINS INFORMATION THAT IS PROPRIETARY TO MOLEX INCORPORATED AND SHOULD NOT BE USED WITHOUT WRITTEN PERMISSION

PART LIST

Molex PN:	Engineering No.:
1210550161	E653P3NA1311C4H
1210550292	E653P3NA1311C4M

DRAWING UPDATE EC NO: IPG2013-1505 DRWN: JMARSZALEK 2013/03/28 CHKD: APPR: MIWASIECZKO 2013/04/02	REV DESCRIPTION B	QUALITY SYMBOLS ▽=0 ▣=0	GENERAL TOLERANCES (UNLESS SPECIFIED) <table border="1"> <thead> <tr> <th></th> <th>mm</th> <th>INCH</th> </tr> </thead> <tbody> <tr> <td>4 PLACES</td> <td>± ---</td> <td>± ---</td> </tr> <tr> <td>3 PLACES</td> <td>± ---</td> <td>± ---</td> </tr> <tr> <td>2 PLACES</td> <td>± ---</td> <td>± ---</td> </tr> <tr> <td>1 PLACE</td> <td>± ---</td> <td>± ---</td> </tr> <tr> <td>0 PLACE</td> <td>± ---</td> <td>± ---</td> </tr> </tbody> </table>			mm	INCH	4 PLACES	± ---	± ---	3 PLACES	± ---	± ---	2 PLACES	± ---	± ---	1 PLACE	± ---	± ---	0 PLACE	± ---	± ---	DIMENSION STYLE MM ONLY	SCALE 1:1	DESIGN UNITS METRIC	FIRST ANGLE PROJECTION
		mm	INCH																							
	4 PLACES	± ---	± ---																							
	3 PLACES	± ---	± ---																							
	2 PLACES	± ---	± ---																							
	1 PLACE	± ---	± ---																							
0 PLACE	± ---	± ---																								
			DRAWN BY JMARSZALEK	DATE 2013/01/16	TITLE E65XXXXXXXX1XXXX DUAL DIN FORM A																					
			CHECKED BY MSZWAJKOWSKI	DATE 2013/01/16																						
			APPROVED BY MIWASIECZKO	DATE 2013/02/12																						
			MATERIAL NO. SEE SHEET 2&3		DOCUMENT NO. SD-121055-001			SHEET NO. 4 OF 4																		
			DRAFT WHERE APPLICABLE MUST REMAIN WITHIN DIMENSIONS		THIS DRAWING CONTAINS INFORMATION THAT IS PROPRIETARY TO MOLEX INCORPORATED AND SHOULD NOT BE USED WITHOUT WRITTEN PERMISSION																					