

NOTES:

1. METALSHELLS: STEEL; min. 315µm TIN over 40-80µm NICKEL
2. INSULATORS: PBT GF UL 94 V-0, BLACK
3. SIGNAL CONTACTS: COPPER ALLOY; PLATING (SEE PART NO.):
 - PLEASE ADD A for GOLD FLASH over NICKEL (PREFERRED TYPE)
 - PLEASE ADD B for 20µm HARD GOLD over min. 50µm NICKEL
 - PLEASE ADD C for 30µm HARD GOLD over min. 50µm NICKEL
4. METAL BRACKETS: ZINC DIE CAST; 300µm COPPER/40-120µm NICKEL/120-200µm TIN
5. THREADED INSERTS: COPPER ALLOY; min. 200µm TIN over 80µm NICKEL
6. FIXING-PLATE: PBT GF UL 94 V-0, BLACK
7. MAXIMUM TORQUE VALUE FOR THREAD: 6 in.LB
8. CONNECTOR IS PART MARKED: **163□13079X CONEC ABC** (see note 3)

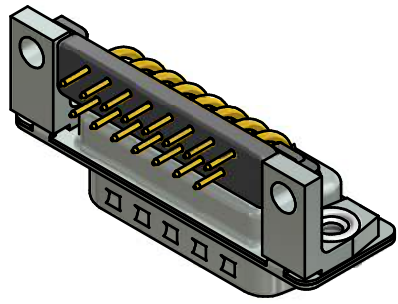

Directive 2002/95/EC RoHS compliant

tolerance				dim. in mm		scale: 2:1 (5:1)	
				material: SEE NOTES		title:	
date				name		D-SUB MALE 90° 15pos. SOLDER PIN ANGLED 0.318inch with threaded insert, metal bracket, fixing-plate	
				drawn 21.02.14 Schmidt			
appd. 21.02.14 Lehmenkühler		norm		dwg no:			
d-old		16K1A1323		part no:		16K1A3398 (b)	
1 x b		Ä5104		21.02.14		HS	
a		Original				sh: 1	
rev.		description		date		name	
						part no: 163□13079X (see note 3)	

THIS DRAWING MAY NOT BE COPIED OR REPRODUCED IN ANY WAY, AND MAY NOT BE PASSED ON TO A THIRD PARTY WITHOUT WRITTEN PERMISSION. OWNERSHIP AND COPYRIGHT OF CONEC GmbH DO NOT ALTER CAD DRAWING BY HAND