

THIS DRAWING IS UNPUBLISHED. RELEASED FOR PUBLICATION
 © COPYRIGHT - By - ALL RIGHTS RESERVED.

LOC	DIST	REVISIONS					
		P	LTR	DESCRIPTION	DATE	DWN	APVD
AJ	16		A2	REVISED PER ECO-11-005030	11MAR11	RK	HMR

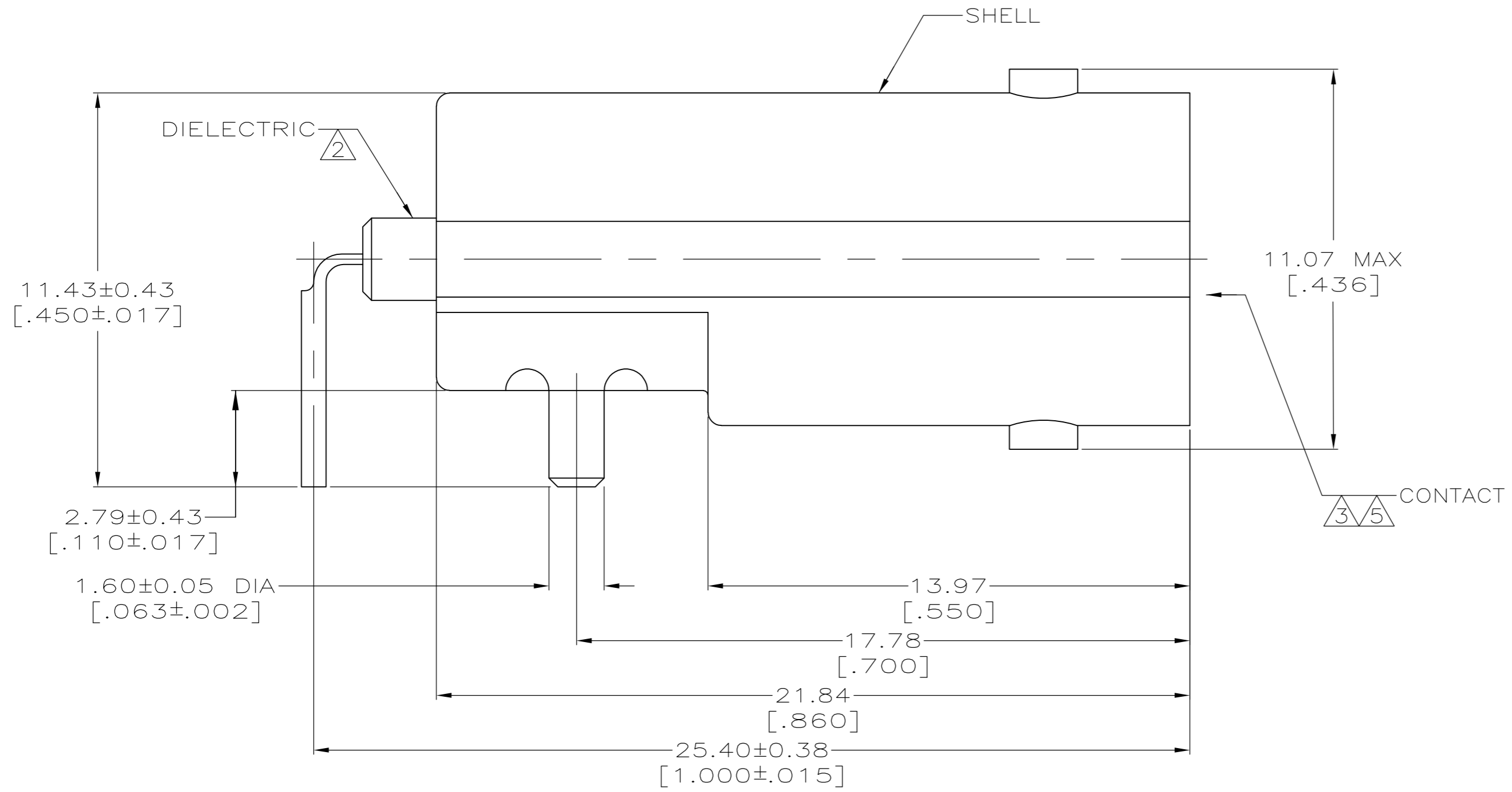

- 1 ZINC PER QQ-Z-363.
- 2 POLYMETHYLPENTENE, GENERAL PURPOSE.
- 3 PHOSPHOR BRONZE PER QQ-B-750.
- 4 NICKEL PLATE PER QQ-N-290, 3.81 μm [.000150] MINIMUM THICK.
- 5 GOLD PLATE PER ASTM B 488, 0.76 μm [.000030] MINIMUM THICK.
- 6 ZAMAK 8
- 7 OBSOLETE PARTS: OBSOLETE CIS STREAMLINING PER D.RENAUD/D.SINISI

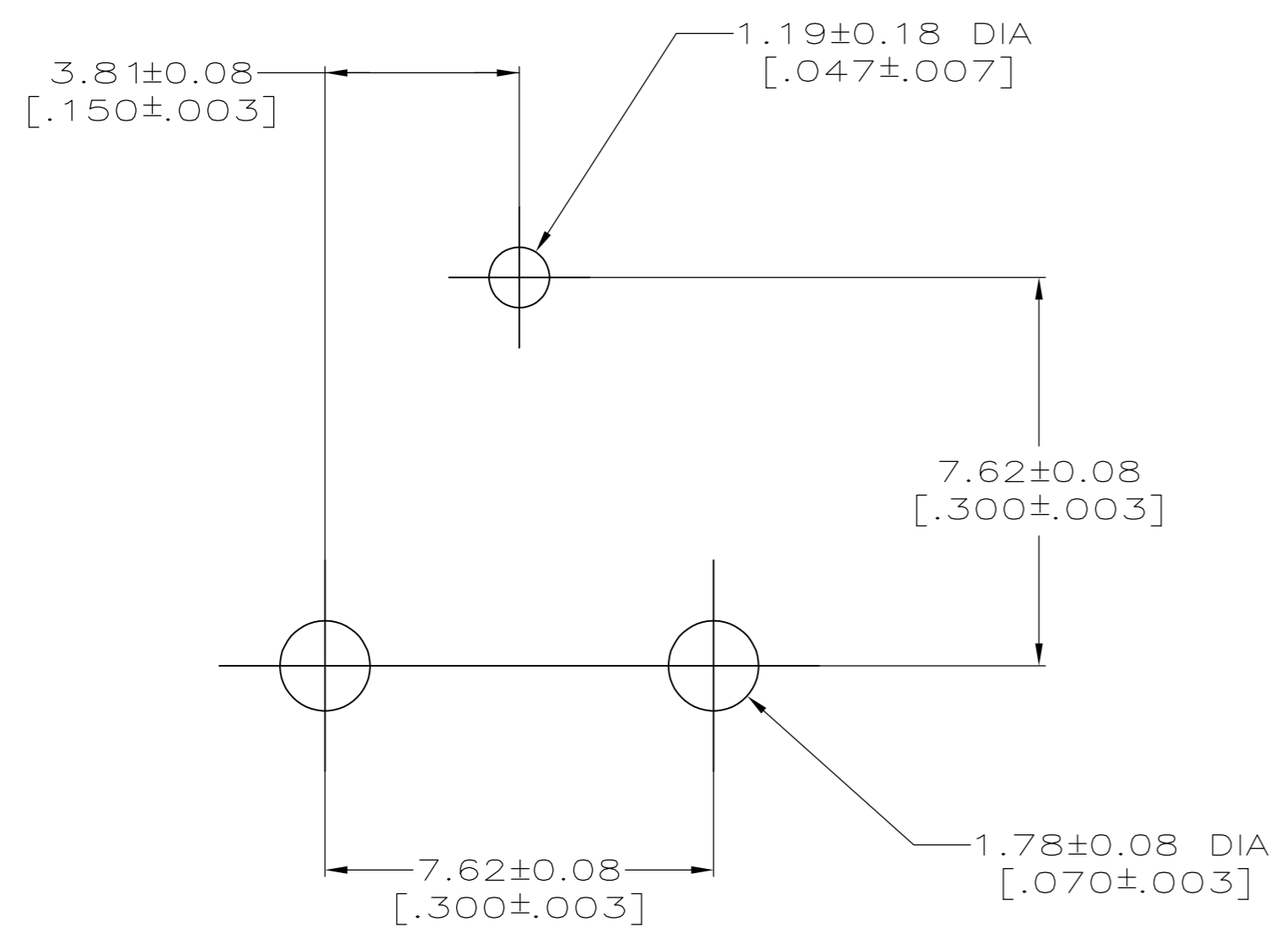

SUGGESTED PCB CONFIGURATION

7 OBSOLETE	4	6	5414373-2
	4	1	5414373-1
	SHELL FINISH	SHELL MATERIAL	PART NO

THIS DRAWING IS A CONTROLLED DOCUMENT.		DWN	J. ALCORTA - DOCK5	26APR2005	TE Connectivity		
DIMENSIONS: mm [INCHES]		CHK	J. HAVENER	26APR2005	NAME		
TOLERANCES UNLESS OTHERWISE SPECIFIED:		APVD	J. LIPPERT	26APR2005	PRODUCT SPEC		
0 PLC ± -		APPLICATION SPEC		108-12078			
1 PLC ± -		WEIGHT		-			
2 PLC ± 0.13 [.005]		SIZE		A2		CAGE CODE	DRAWING NO
3 PLC ± -		SCALE		8:1		SHEET	1 of 1
4 PLC ± -		CUSTOMER DRAWING		00779		REV	A2
ANGLES ± 5°		FINISH		C=5414373		RESTRICTED TO	-
MATERIAL SEE NOTES 1-3, 6		FINISH SEE NOTES 4 - 5		SCALE		SHEET	