

RAD-ISM-900-SET

Wireless I/O Interface Transmitter Receiver Set



Data sheet
2875_en_B

© PHOENIX CONTACT 2011-12-13

1 Description

Unidirectional wireless systems comprise a transmitter (Tx) and a receiver (Rx).

The transmitter accommodates two digital signals in the range from 5... 30 V AC/DC or 100... 240 V AC and one analog current signal (4... 20 mA). These signals are available for further processing at the receiver in the form of two relay contacts and one 4... 20 mA current output. In addition, a third relay in the receiver diagnoses the status of the wireless connection (RF link).

The wireless connection is established automatically when the operating voltage U_B is applied at both modules. When the connection has been established, the "RF-Link" LED is ON in the receiver and the RF link relay has picked up. From now on, data transmission occurs every 27 ms and the radio frequency is switched.

The modules are supplied with a hopkey. Unique information about each wireless system is stored on the hopkey (the hop frequency used, the sequence, ID, etc.).

In order to install another module in an existing wireless system, the module must be assigned to this system. This is

done by assigning the hopkey of the existing receiver to the new receiver module.

1.1 Housing types

Depending on the application, there are two housing types available for the transmitter:

- DIN rail mountable housing for mounting in the control cabinet.
- Rugged outdoor housing for direct mounting outdoors without an additional control cabinet.

2 Features

- 1 W transmitter
- Uses frequency-hopping, spread spectrum technology in the 902-928 MHz ISM band
- No programming required
- All modules are Class I, Division 2 Groups A, B, C, D listed



These devices are only for export outside the European Economic region.



Make sure you always use the latest documentation.
It can be downloaded at www.phoenixcontact.net/catalog.



This data sheet is valid for all products listed on the following page:

3 Table of Contents

1	Description.....	1
1.1	Housing types	1
2	Features	1
3	Table of Contents	2
4	Ordering Data	3
5	RAD-ISM-900-SET-UD-ANT (2867102)	3
5.1	Technical Data	3
5.2	Block diagrams.....	5
5.3	Safety regulations.....	5
5.4	Structure	6
5.5	Installation	7
5.6	Function elements	7
5.7	Connection examples.....	8
5.8	Additional receivers	12
6	Outdoor Modules	13
6.1	Technical Data	13
6.2	Block Diagrams	15
6.3	Safety regulations.....	15
6.4	Installation	16
6.5	Function elements	16
6.6	Connection examples.....	17
6.7	Additional receivers	19
7	System Versions	19
7.1	Point-to-point.....	19
7.2	Point-to-multipoint	20
8	Autonomous Power Supply of Wireless Modules	20

4 Ordering Data

Unidirectional wireless transmission system

Description	Type	Order No.	Pcs./Pkt.
Wireless set , includes 100-240 V AC IP65 transmitter, 12-30 V DC receiver, two omni-directional antennas	RAD-ISM-900-SET-AC-UD	2867021	1
Wireless set , includes 12-30 V DC IP65 transmitter, 12-30 V DC receiver, two omni-directional antennas	RAD-ISM-900-SET-DC-UD	2867034	1
Wireless set , includes 12-30 V DC transmitter in ME housing, 12-30 V DC receiver, two omni-directional antennas	RAD-ISM-900-SET-UD-ANT	2867102	1

Individual (replacement) modules

Description	Type	Order No.	Pcs./Pkt.
Transmitter , in ME housing	RAD-ISM-900-TX	2867076	1
Transmitter , in IP65 housing, 12-30 V DC	RAD-ISM-900-TX-DC	2867348	1
Transmitter , in IP65 housing, 100-240 V AC	RAD-ISM-900-TX-AC	2867335	1
Receiver , in ME housing	RAD-ISM-900-RX	2867047	1

Accessories

Description	Type	Order No.	Pcs./Pkt.
Antenna , 7 dBi gain, omni-directional, IP65, connection N-type (female)	RAD-ISM-900-ANT-OMNI-5	2867199	1
Antenna , 5 dBi gain, panel, yagi-directional, IP65, 1.5 m cable length, type N connector (female)	RAD-ISM-900-ANT-YAGI-3-N	2867801	1
Cable , 7.6 m (25 ft.) RG213 with type N connectors (male)	RAD-CAB-RG213-25	2867597	1
Adapter cable , 1.2 m (4 ft.) RG316 with type N (male) and MCX (male) connectors	RAD-CON-MCX90-N-SS	2885207	1

5 RAD-ISM-900-SET-UD-ANT (2867102)

5.1 Technical Data

Power Supply	RAD-ISM-900-TX (2867076)	RAD-ISM-900-RX (2867047)
Supply voltage U_S	24 V DC	24 V DC
Supply voltage range	12 ... 30 V DC	12 ... 30 V DC
Current consumption, typical (at U_S)	75 mA	85 mA
Current consumption, maximum (at U_S)	350 mA	125 mA

Analog Input (TX)

Signal range	4 ... 20 mA
Overload capability range	10%
Underload capability range	5%
Input resistance	< 150 Ω
Supply for passive sensors	Terminal block 7; U_S

Analog Output (RX)

Signal range	4 ... 20 mA
Overload capability range	10%
Underload capability range	5%
Maximum load resistance	$R_B = (U_B - 10 \text{ V})/20 \text{ mA}$
Tolerance at 25°C	
Accuracy	0.20% of full scale
Repeatability	0.02%

Digital Input (TX)

Signal range	5 ... 30 V
High signal, minimum	5 V DC
Low signal, maximum	1.5 V DC

Digital Output + RF link (RX)

Contact type	3 floating PDT
Contact material of terminal block	Ag, gold-plated
Maximum switching voltage	30 V AC/DC
Maximum switching current	0.5 A
Maximum switching frequency	2 Hz
Mechanical service life	1×10^7 cycles
Electrical service life (at 0.5 A switching current)	8×10^5 cycles

Wireless Interface

Frequency range	902 ... 928 MHz
Number of channels (groups/channels per group)	4/63
Transmission power	1 W (30 dBm)

General Data

Housing material	Polyamide PA, non-reinforced
Degree of protection	IP20
Mounting	On NS35 DIN rail according to EN 60715
Mounting position	Any
Dimensions (W x H x D)	17.5 mm x 99 mm x 114.5 mm
Weight (approximately)	
Transmitter (TX)	149 g
Receiver (RX)	137 g
Conductor cross-section	0.2... 2.5 mm ²
Temperature range, operating	-40°C... 70°C
Temperature range, storage	-40°C... 85°C
Relative humidity, non-condensing	20... 95%

Indicators

RF-Link: Green LED	On/Off	On/Off/Flashing
Digital 1 + 2: Green LED	On/Off	On/Off

Conformity/Approvals

FCC	Part 15.247
U L/cUL	Individual modules are Class I, Division 2 Groups A, B, C, D listed

5.2 Block diagrams

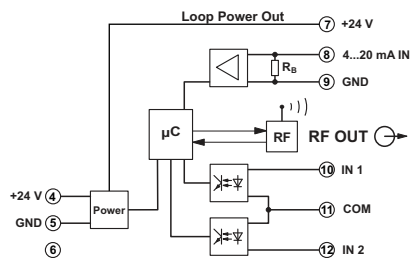

Figure 1 Transmitter block diagram

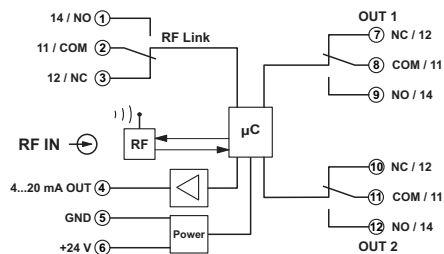

Figure 2 Receiver block diagram

5.3 Safety regulations

Installation notes



The unidirectional wireless system should only be operated using authorized accessories from Phoenix Contact. The use of other accessory components may invalidate the device approval status.



WARNING:

- Installation, operation, and maintenance may only be carried out by qualified electricians. Follow the installation instructions described. When installing and operating the device, the applicable regulations and safety directives (including national safety directives), as well as general technical regulations, must be observed. Observe the technical data in this data sheet and subsequent documentation (www.phoenixcontact.com).
- In order to protect the modules against electrostatic discharge when working on control cabinets, the operating personnel must remove electrostatic discharge before opening control boxes or control cabinets and before touching the modules.
- The modules are snapped onto a DIN rail within a control cabinet or control box. The control cabinet/box must have at least an IP54 degree of protection.
- The device must not be opened or modified. Do not repair the device yourself, replace it with an equivalent device. Repairs may only be carried out by the manufacturer. The manufacturer is not liable for damage resulting from violation.
- The IP20 degree of protection of the device is intended for use in a clean and dry environment. The device must not be subject to any strain or load, which exceeds the limits described.
- In the electrical system of the building, a 2-position disconnecting device must be provided to isolate the equipment from the supply circuit.

Installation in the hazardous area (Class I, Division 2)



WARNING:

- The device is not designed for use in atmospheres with a danger of dust explosions.
- Observe the specified conditions for use in potentially explosive areas.
- Install the device in housing (control or distributor box) that meets the requirements of EN 60079-15 and has at least IP54 protection.
- Only purely resistive antennas may be operated on the devices.
- The device must be stopped and immediately removed from the hazardous area if it is damaged or was subject to an impermissible load or stored incorrectly or if it malfunctions.

5.4 Structure

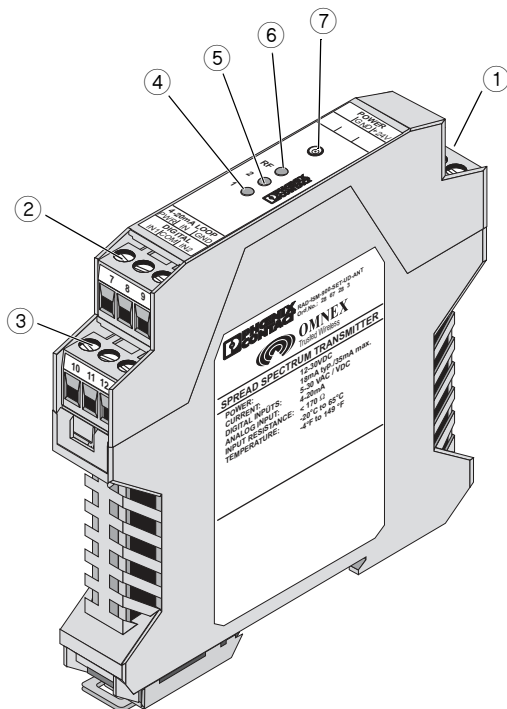

Transmitter:

- ① Connector: Operating voltage U_B
- ② Connector: 4 ... 20 mA input
- ③ Connector: Digital inputs
- ④ LED: Digital Input 1
- ⑤ LED: Digital Input 2
- ⑥ LED: RF-Link (TX active)
- ⑦ Antenna connection

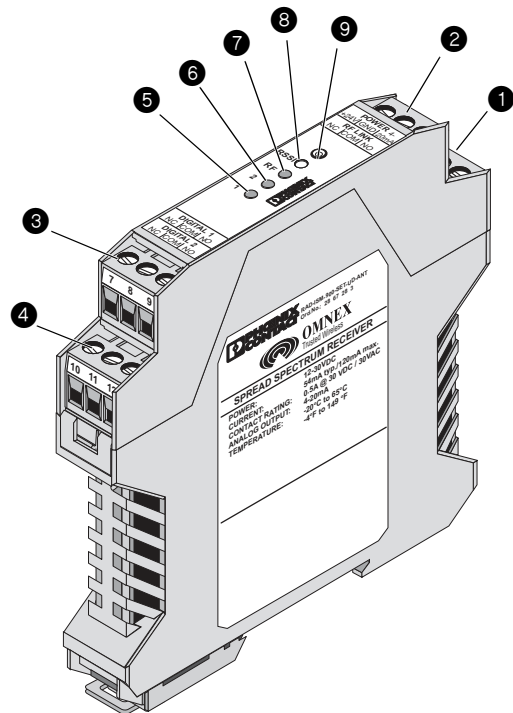

Receiver:

- ① Connector: Operating voltage U_B + analog output
- ② Connector: RF link relay
- ③ Connector: Digital output 1
- ④ Connector: Digital output 2
- ⑤ LED: Digital Output 1
- ⑥ LED: Digital Output 2
- ⑦ LED: RF-Link (RX active)
- ⑧ RSSI test socket
- ⑨ Antenna connection

Figure 3 Connections and indicators

5.5 Installation



WARNING:

In potentially explosive areas, only snap on and connect cables when the power is disconnected.



When installing the wireless modules, please refer to the instructions in the module-specific installation note.

The modules are snapped onto a DIN rail within a control cabinet or control box.

In the electrical system of the building, a 2-position disconnecting device must be provided to isolate the equipment from the supply circuit.



NOTE: Electrostatic discharge!

The device contains components that can be damaged or destroyed by electrostatic discharge. When handling the device, observe the necessary safety precautions against electrostatic discharge (ESD), in accordance with EN 61340-5-1 and IEC 61340-5-1.



Observe the installation instructions for the antenna used. The antenna cable is plugged into the antenna connectors.

5.6 Function elements

5.6.1 Transmitter

Display and diagnostic elements

Digital input 1 LED = Status of digital input 1

Digital input 2 LED = Status of digital input 2

RF-Link LED

On = operating voltage U_B present, transmitter is sending data

Analog inputs

The 4... 20 mA analog input detects active and passive current sensors. For passive current sensors, the unregulated operating voltage U_B is provided at terminal block 7.

Digital inputs

Both digital inputs on the transmitter can process voltages from 5... 30 V AC/DC. They have a common ground potential (terminal block 1) and are electrically isolated from the operating voltage U_B .

In addition to the antennas included in the scope of supply, other antennas are available in our range of accessories for optimizing the wireless path.

5.6.2 Receiver

Display and diagnostic elements

RF link relay

The RF link relay in the receiver diagnoses the status of the wireless connection. It picks up when the wireless connection is established.

If no data packets are received correctly over a period of approximately 4 seconds, the relay drops out. It picks up again automatically when the wireless connection is re-established. The RF link relay functions as a PDT contact for the ME modules.

Digital Output 1 LED = Status of digital output 1

Digital Output 2 LED = Status of digital output 2

RF-Link LED

OFF = No operating voltage U_B

Flashes slowly = No reception

Flashes quickly = Weak connection

ON = Wireless connection established

RSSI test socket

A voltage measuring device (handheld multimeter) can be connected to the RSSI test socket to measure a voltage to ground, which provides information about the received wireless signal. Using Figure 4, the received signal strength, in dB, can be determined using the voltage value. This can be useful when positioning and aligning the antenna.

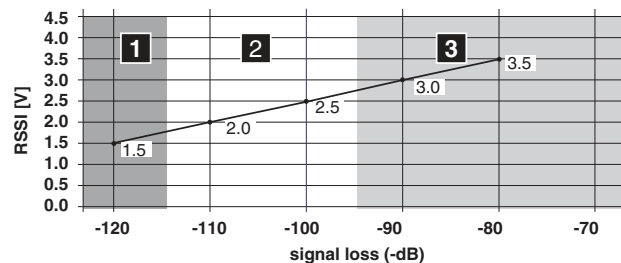

Figure 4 RSSI diagram

- = No connection
- = Fair connection
- = Good connection

Analog output (also operating voltage)

The analog output is supplied internally from the unregulated operating voltage U_B . At the current source (terminal block 4), the actuator to be connected is wired to ground (terminal block 5).

The output requires an internal drop voltage of 10 V.

The maximum load at the current output with a nominal voltage of 24 V = $(24\text{ V} - 10\text{ V})/20\text{ mA} = 700\ \Omega$. The maximum load therefore depends on the operating voltage U_B used.

Digital outputs

Two floating PDT contacts are used as the digital outputs for the receiver.

5.6.3 Behavior in the event of the wireless connection being interrupted

If the wireless connection is interrupted, all outputs (analog and digital) retain their last value or status (hold response, see "Connection examples").

To configure a reset response (revert back to "0") for a digital signal or the analog signal when a wireless connection is interrupted, connect the RF link relay contact in series, for example.

To configure a reset response for all signals, use the RF link relay to control one or more additional relays.

5.7 Connection examples

5.7.1 Transmitter

i For notes on avoiding ground loops, see Figure 11.

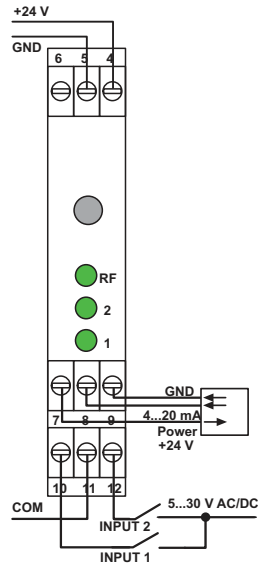

Figure 5 3-wire passive current sensor

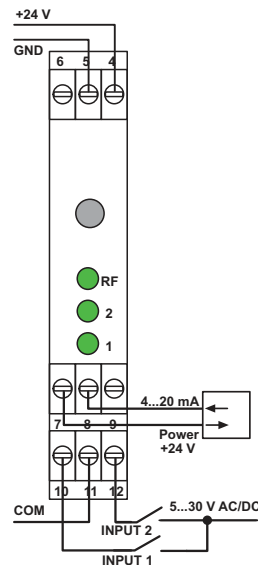

Figure 6 2-wire passive current sensor

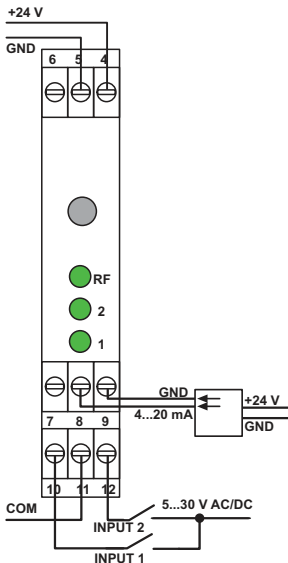

Figure 7 Active current sensor with separate supply

5.7.2 Receiver

Connection scheme for hold response of all outputs

Figure 8 shows a hold response connection method. This method retains the states of the digital outputs and the analog signal when the wireless connection is interrupted.

- NO = Normally open contact
- NC = Normally closed contact

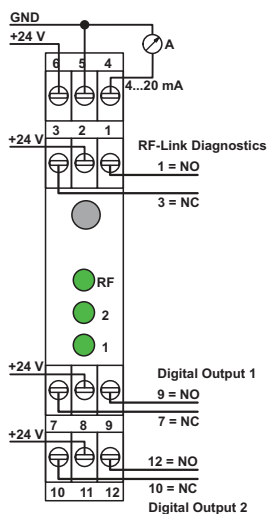

Figure 8 Hold response for all outputs

Connection scheme for reset response of the digital outputs

Figure 9 shows the RF link relay is connected to the digital outputs in series. This means that the digital outputs are set to 0 when the wireless connection is interrupted.

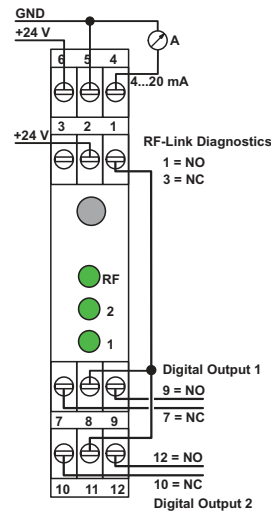

Figure 9 Reset response for all digital outputs

Connection scheme for reset response of the analog outputs

Figure 10 shows the RF link relay is connected to the analog output in series. This means that the analog output is set to 0 mA when the wireless connection is interrupted.

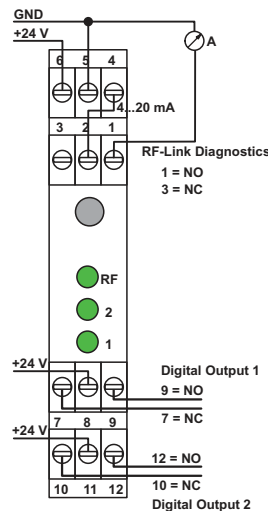

Figure 10 Reset response for all digital outputs



The reset response sets the output to 0 mA.

5.7.3 Avoiding ground loops



NOTE:

Differential voltages may occur between the potentials when the ground connections are physically separated. These voltages may cause compensating currents over the low-resistance path marked red. Just a few volts can cause compensating currents in the range of several amperes, which may damage the module.

used for the sensor and the RAD-ISM-900-SET... module, and when the two sources have a separate ground reference. This arrangement (using different sources for sensor and RAD-ISM-900-SET...) does not always cause problems. However, high compensating currents (in the range of several amperes) may cause damage to the module. To avoid these effects, the complete arrangement must only be grounded at one central point (e.g., not using the connection to ground connection 2).

Figure 11 shows the course of the compensating currents, which is created when different supply voltage sources are

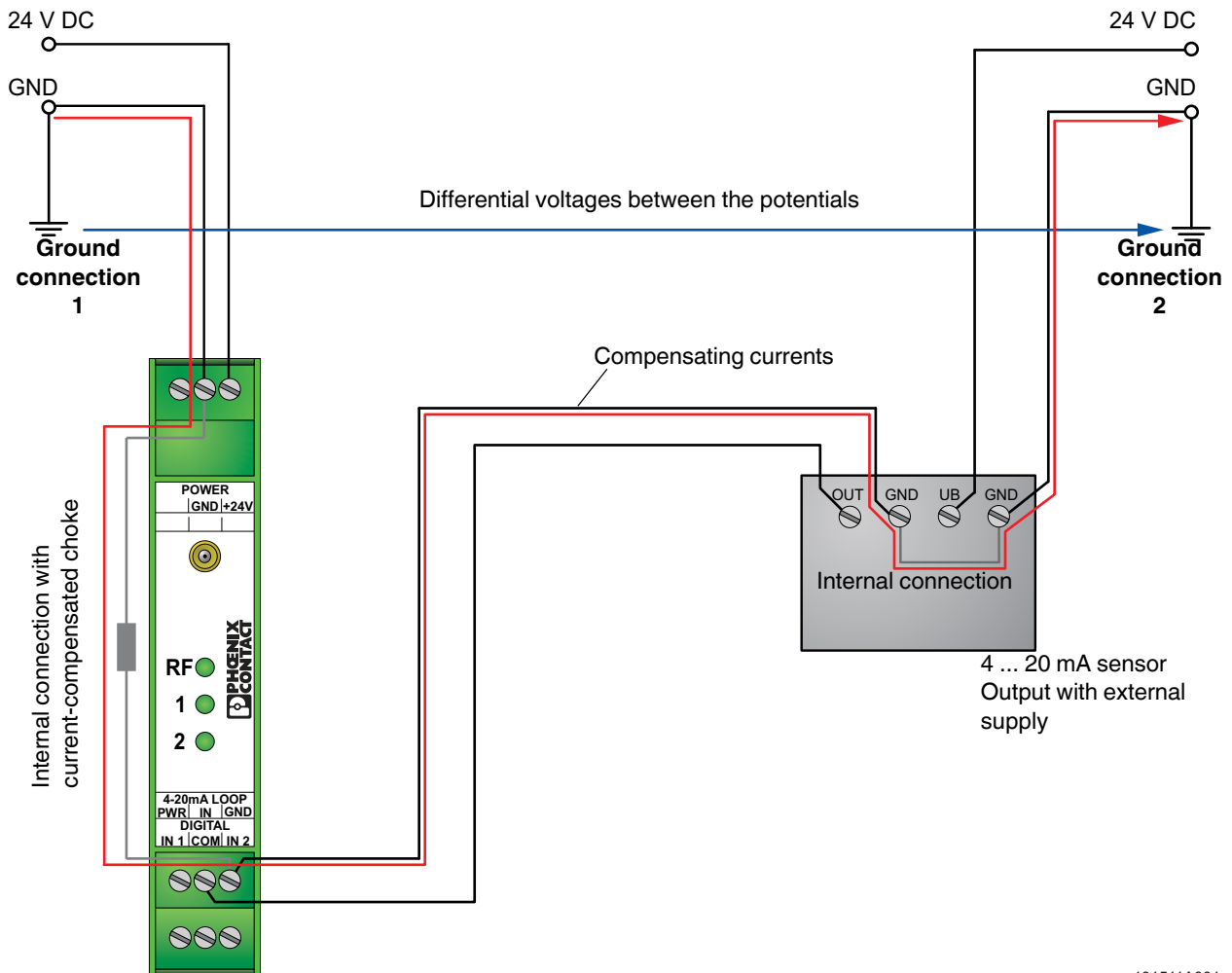

101511A001

Figure 11 Avoiding ground loops



NOTE:
When using surge protection for the antenna cable, make sure that the ground connection of the surge protection solution has the same potential as the power supply ground connection (Ground connection 1 as shown in Figure 11).

5.7.4 Installation in the hazardous area



WARNING:
In potentially explosive areas, only snap on and connect cables when the power is disconnected.



NOTE:
Installation and startup must only be carried out by qualified personnel. The relevant country-specific regulations must be observed.

With certification according to UL/cUL, the unidirectional RAD-ISM-900-SET... wireless modules can be used

internationally in Class I, Division 2 areas with hazardous gases. Signals from outside the hazardous area, as well as signals from Division 2, can be connected directly. Signals from Division 1 cannot be connected directly. They can only be connected via the appropriate barriers because the inputs are not intrinsically safe.

Due to the limited transmission power, the wireless path itself may be led through Division 2. There are no restrictions here.

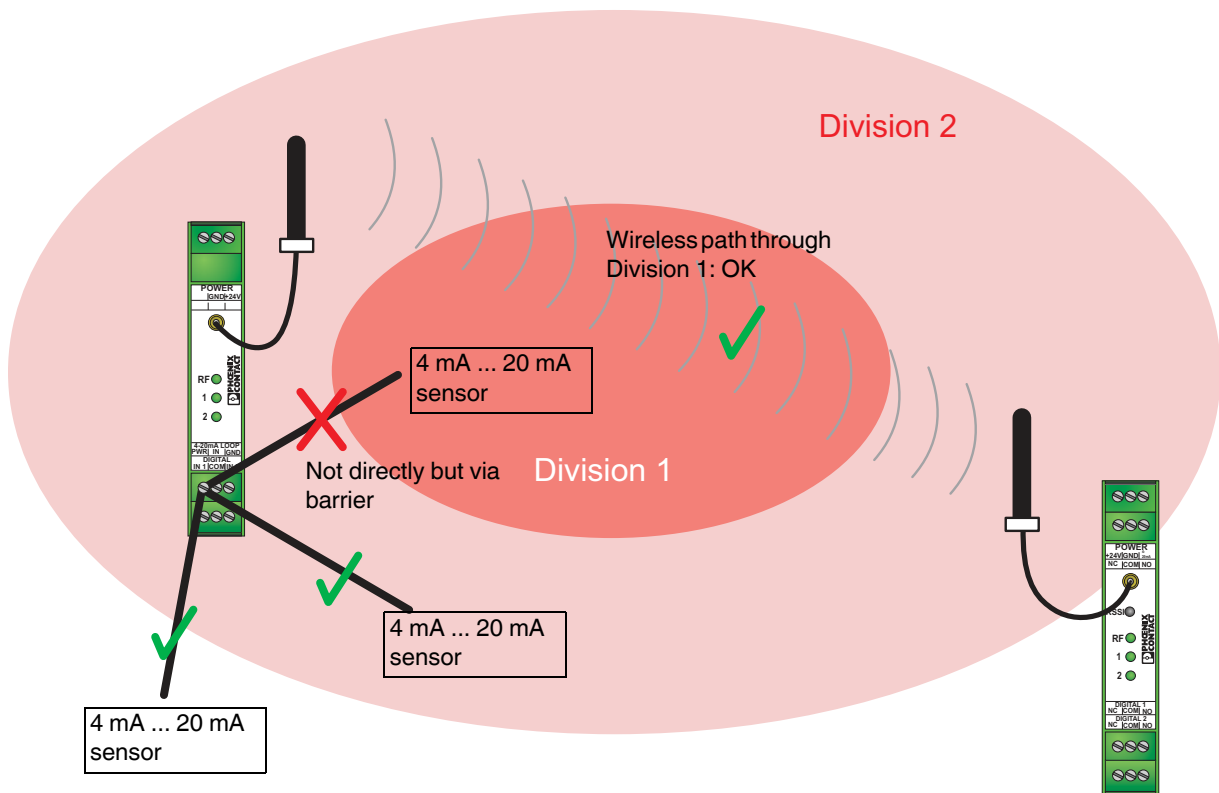

Figure 12 Typical usage in Class I, Division 2

5.8 Additional receivers

Any number of additional receivers can be used. The modules are supplied without a hopkey.

The hopkey contains the transmission frequencies used and the hop sequence. This information is required when installing an additional receiver in an existing system.

To install an additional receiver, proceed as follows:

RAD-ISM-900-RX (Order No. 2867047)



When the supply voltage is connected, the information is transmitted from the connected hopkey to a non-volatile memory inside the module. This hopkey can then be used to “teach” other receivers. The hopkey can be stored in the last receiver. If no hopkey is connected, the information inside the module is used.

1. To protect the modules against ESD, the operating personnel must remove electrostatic discharge at appropriate points (e.g., control cabinet) before touching the modules.
2. The existing system must have established a wireless connection.
3. Disconnect the power to the existing system.

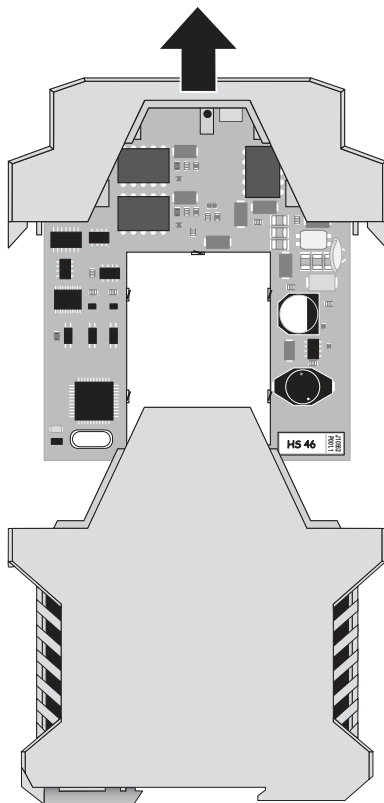

Figure 13 Removing the electronics module

4. Open the housing of the receiver in the existing system by pressing both housing latches on the sides. Remove the electronics module from the housing (see Figure 13).
5. At the bottom right on the PCB is a small PCB in a 10-position base – this is the hopkey. Remove the hopkey and insert it in the same position in the new receiver that you wish to install.

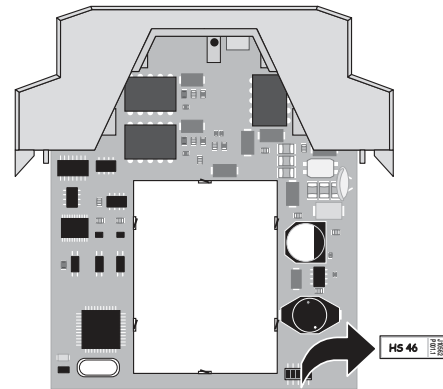

Figure 14 Inserting the hopkey

6. Close all the housing covers and reinsert the modules in the control cabinet(s).
7. Reconnect the supply voltage – the additional receiver now receives the same information as the receiver in the existing system.
8. Repeat the procedure for all additional receivers.

6 Outdoor Modules

RAD-ISM-900-SET-AC-UD (2867021)

RAD-ISM-900-SET-DC-UD (2867034)

6.1 Technical Data

Power Supply	RAD-ISM-900-TX-AC (2867335)	RAD-ISM-900-TX-DC (2867318)	RAD-ISM-900-RX (2867047)
Supply voltage U_S	120 V AC	24 V DC	24 V DC
Supply voltage range	100 ... 240 V AC	12 ... 30 V DC	12 ... 30 V DC
Current consumption, typical (at U_S)	85 mA	75 mA	85 mA
Current consumption, maximum (at U_S)	125 mA	350 mA	125 mA
Analog Input (TX)	RAD-ISM-900-TX-AC (2867335)	RAD-ISM-900-TX-DC (2867318)	RAD-ISM-900-RX (2867047)
Signal range	4 ... 20 mA		
Overload capability range	10%		
Underload capability range	5%		
Input resistance	< 170 Ω		
Supply for passive sensors	24 V DC	U_B	
Analog Output (RX)	RAD-ISM-900-TX-AC (2867335)	RAD-ISM-900-TX-DC (2867318)	RAD-ISM-900-RX (2867047)
Signal range	4 ... 20 mA		
Overload capability range	10%		
Underload capability range	5%		
Maximum load resistance	$R_B = (U_B - 10 \text{ V})/20 \text{ mA}$		
Resolution	16 bits		
Tolerance at 25°C			
Typical	$\pm 0.075\%$ e		
Maximum	$\pm 0.225\%$		
Temperature coefficient at -25 ... +65°C	0.01%K		
Supply for passive sensors	U_B		
Digital Input (TX)	RAD-ISM-900-TX-AC (2867335)	RAD-ISM-900-TX-DC (2867318)	RAD-ISM-900-RX (2867047)
Signal range	85 ... 240 V AC	5 ... 30 V AC/DC	
High signal, minimum	5 V DC	5 V DC	
Low signal, maximum	1.5 V DC	1.5 V DC	
Supply for passive sensors	U_B	U_B	
Digital Output + RF link (RX)	RAD-ISM-900-TX-AC (2867335)	RAD-ISM-900-TX-DC (2867318)	RAD-ISM-900-RX (2867047)
Contact type			3 N/O contacts
Contact material of terminal block			Ag, gold-plated
Maximum switching voltage			30 V AC/DC
Maximum switching current			0.5 A
Maximum switching frequency			2 Hz
Mechanical service life			1×10^8 cycles
Electrical service life (at 0.5 A switching current)			8×10^5 cycles

Wireless Interface

Frequency range	902 ... 928 MHz
Number of channels (groups/channels per group)	4/63
Transmission power	1 W (30 dBm)

General Data

	RAD-ISM-900-TX-AC (2867335)	RAD-ISM-900-TX-DC (2867318)	RAD-ISM-900-RX (2867047)
Housing material	Aluminum/PBT	Aluminum/PBT	Polyamide PA, non-reinforced
Degree of protection	NEMA 4X	NEMA 4X	IP20
Mounting	1/2-in. NPT	1/2-in. NPT	On NS35 DIN rail according to EN 60715
Mounting position	Vertical	Vertical	Any
Dimensions (W x H x D)	57 x 280 x 57 mm	57 x 280 x 57 mm	17.5 x 99 x 114.5 mm
Weight (approximately)	650 g	650 g	137 g
Connections	Flying leads 18 in.	Flying leads 18 in.	Screw terminal
Conductor cross-section			
Power AC	18 AWG	18 AWG	0.2... 2.5 mm ²
Signal DC	20 AWG	20 AWG	0.2... 2.5 mm ²
Temperature range, operating	-40°C... 70°C	-40°C... 70°C	-40°C... 70°C
Temperature range, storage	-40°C... 85°C	-40°C... 85°C	-40°C... 85°C
Relative humidity, non-condensing	0... 100%	0... 100%	20... 95%

Indicators

	RAD-ISM-900-TX-AC (2867335)	RAD-ISM-900-TX-DC (2867318)	RAD-ISM-900-RX (2867047)
RF-Link: Green LED	On/Off	On/Off	On/Off/Flashing
Digital 1 + 2: Green LED	-	-	On/Off

Conformity/Approvals

FCC	Part 15.247
U L/cUL	Individual modules are Class I, Division 2 Groups A, B, C, D listed

6.2 Block Diagrams

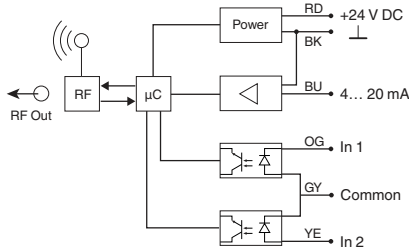

Figure 15 DC transmitter block diagram

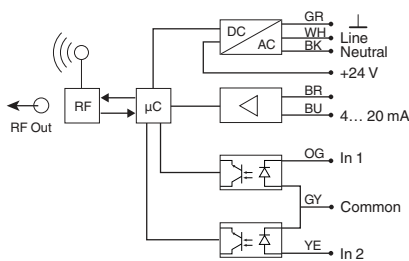

Figure 16 AC transmitter block diagram

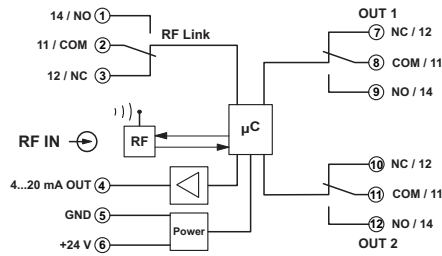

Figure 17 Receiver block diagram

6.3 Safety regulations

Installation notes



The unidirectional wireless system should only be operated using authorized accessories from Phoenix Contact. The use of other accessory components may invalidate the device approval status.



WARNING:

- Installation, operation, and maintenance may only be carried out by qualified electricians. Follow the installation instructions described. When installing and operating the device, the applicable regulations and safety directives (including national safety directives), as well as general technical regulations, must be observed. Observe the technical data in this data sheet and subsequent documentation (www.phoenixcontact.com).
- In order to protect the modules against electrostatic discharge when working on control cabinets, the operating personnel must remove electrostatic discharge before opening control boxes or control cabinets and before touching the modules.
- The modules are snapped onto a DIN rail within a control cabinet or control box. The control cabinet/box must have at least an IP54 degree of protection.
- The device must not be opened or modified. Do not repair the device yourself, replace it with an equivalent device. Repairs may only be carried out by the manufacturer. The manufacturer is not liable for damage resulting from violation.
- The IP20 degree of protection of the device is intended for use in a clean and dry environment. The device must not be subject to any strain or load, which exceeds the limits described.
- In the electrical system of the building, a 2-position disconnecting device must be provided to isolate the equipment from the supply circuit.

Installation in the hazardous area (Class I, Division 2)



WARNING:

- The device is not designed for use in atmospheres with a danger of dust explosions.
- Observe the specified conditions for use in potentially explosive areas.
- Install the device in housing (control or distributor box) that meets the requirements of EN 60079-15 and has at least IP54 protection.
- Only purely resistive antennas may be operated on the devices.
- The device must be stopped and immediately removed from the hazardous area if it is damaged or was subject to an impermissible load or stored incorrectly or if it malfunctions.

6.4 Installation



WARNING:
In potentially explosive areas, only snap on and connect cables when the power is disconnected.



When installing the wireless modules, please refer to the instructions in the module-specific installation note.

The TX modules are equipped with weather-proof housing and can be installed directly outdoors. They are mounted on 1/2-in. NPT conduit or pipe. The RX module is snapped onto a DIN rail within a control cabinet or control box.

In the electrical system of the building, a 2-position disconnecting device must be provided to isolate the RX receiver from the supply circuit.



NOTE: Electrostatic discharge!
The RX device contains components that can be damaged or destroyed by electrostatic discharge. When handling the device, observe the necessary safety precautions against electrostatic discharge (ESD), in accordance with EN 61340-5-1 and IEC 61340-5-1.



Observe the installation instructions for the antenna used. The antenna cable is plugged into the antenna connectors.

6.5 Function elements

6.5.1 Transmitter

Display and diagnostic elements

RF-Link LED
On = operating voltage U_B present, transmitter is sending data

The RF link relay in the receiver diagnoses the

Analog input

The 4... 20 mA analog input detects active and passive current sensors. For passive current sensors, the unregulated operating voltage U_B is provided.

Digital inputs

Both digital inputs on the RAD-ISM-900-TX-DC transmitter can process voltages from 5... 30 V AC/DC. They have a common ground potential.

In addition to the antennas included, other omni-directional and yagi-directional antennas are available in our range of accessories for optimizing the wireless path. A special pigtail (adapter cable) may be required, depending on the antenna selected (see "Ordering Data" on page 3).

6.5.2 Receiver

Display and diagnostic elements

RF link relay
The RF link relay in the receiver diagnoses the status of the wireless connection. It picks up when the wireless connection is established.

If no data packets are received correctly over a period of approximately 4 seconds, the relay drops out. It picks up again automatically when the wireless connection is re-established. The RF link relay functions as a PDT contact for the ME modules.

Digital Output 1 LED = Status of digital output 1

Digital Output 2 LED = Status of digital output 2

RF-Link LED
OFF = No operating voltage U_B
Flashes slowly = No reception
Flashes quickly = Weak connection
ON = Wireless connection established

RSSI test socket

A voltage measuring device (handheld multimeter) can be connected to the RSSI test socket to measure a voltage to ground, which provides information about the received wireless signal. Using Figure 4, the received signal strength, in dB, can be determined using the voltage value. This can be useful when positioning and aligning the antenna.

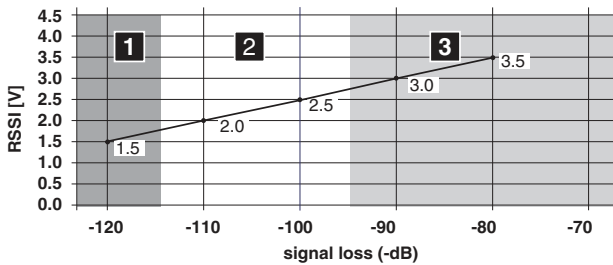

Figure 18 RSSI diagram

- = No connection
- = Fair connection
- = Good connection

Analog outputs (also operating voltage)

The analog output is supplied internally from the unregulated operating voltage U_B . At the current source (pin 3), the actuator to be connected is wired to ground (pin 4).

The output requires an internal drop voltage of 10 V. The maximum load at the current output with a nominal voltage of 24 V = $(24\text{ V} - 10\text{ V})/20\text{ mA} = 700\ \Omega$. The maximum load therefore depends on the operating voltage U_B used.

Digital outputs

Two floating PDT contacts are used as the digital outputs for the receiver.

6.5.3 Behavior in the event of the wireless connection being interrupted

If the wireless connection is interrupted, all outputs (analog and digital) retain their last value or status (hold response, see connection examples on page xx).

To configure a reset response (revert back to "0") for a digital signal or the analog signal when a wireless connection is interrupted, connect the RF link relay contact in series, for example.

To configure a reset response for all signals, use the RF link relay to control one or more additional relays.

6.6 Connection examples

6.6.1 RAD-ISM-900-TX-DC transmitter

i For notes on avoiding ground loops, see Figure 11.

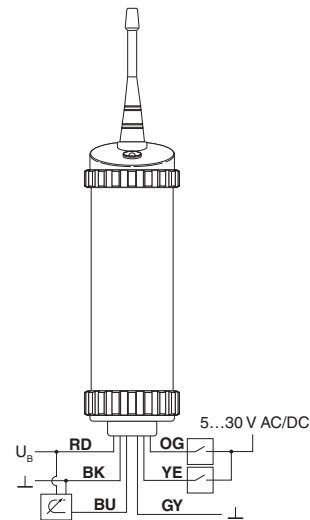

Figure 19 3-wire passive current sensor

6.6.2 RAD-ISM-900-TX-AC transmitter

i For notes on avoiding ground loops, see Figure 11.

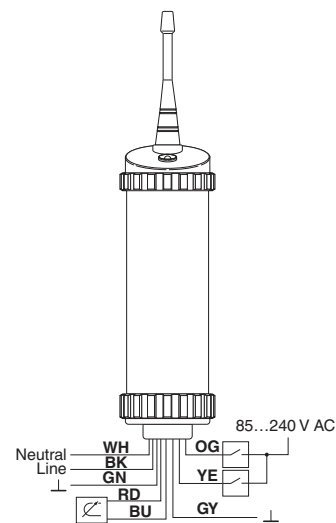

Figure 20 2-wire passive current sensor

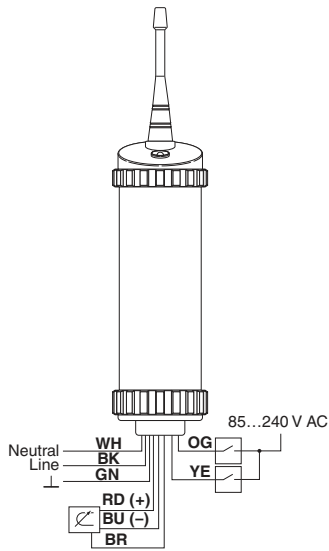

Figure 21 3-wire passive current sensor

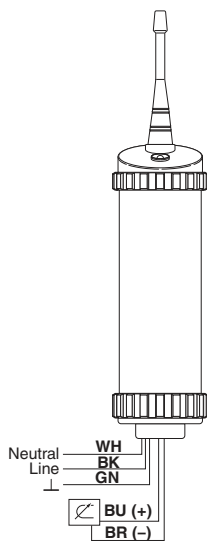

Figure 22 4-wire passive current sensor

6.6.4 Installation in the hazardous area



WARNING:

In potentially explosive areas, only snap on and connect cables when the power is disconnected.



NOTE:

Installation and startup must only be carried out by qualified personnel. The relevant country-specific regulations must be observed.

With certification according to UL/cUL, the unidirectional RAD-ISM-900-SET... wireless modules can be used internationally in Class I, Division 2 areas with hazardous gases. Signals from outside the hazardous area, as well as signals from Division 2, can be connected directly. Signals from Division 1 cannot be connected directly. They can only be connected via the appropriate barriers because the inputs are not intrinsically safe.

Due to the limited transmission power, the wireless path itself may be led through Division 2. There are no restrictions here.

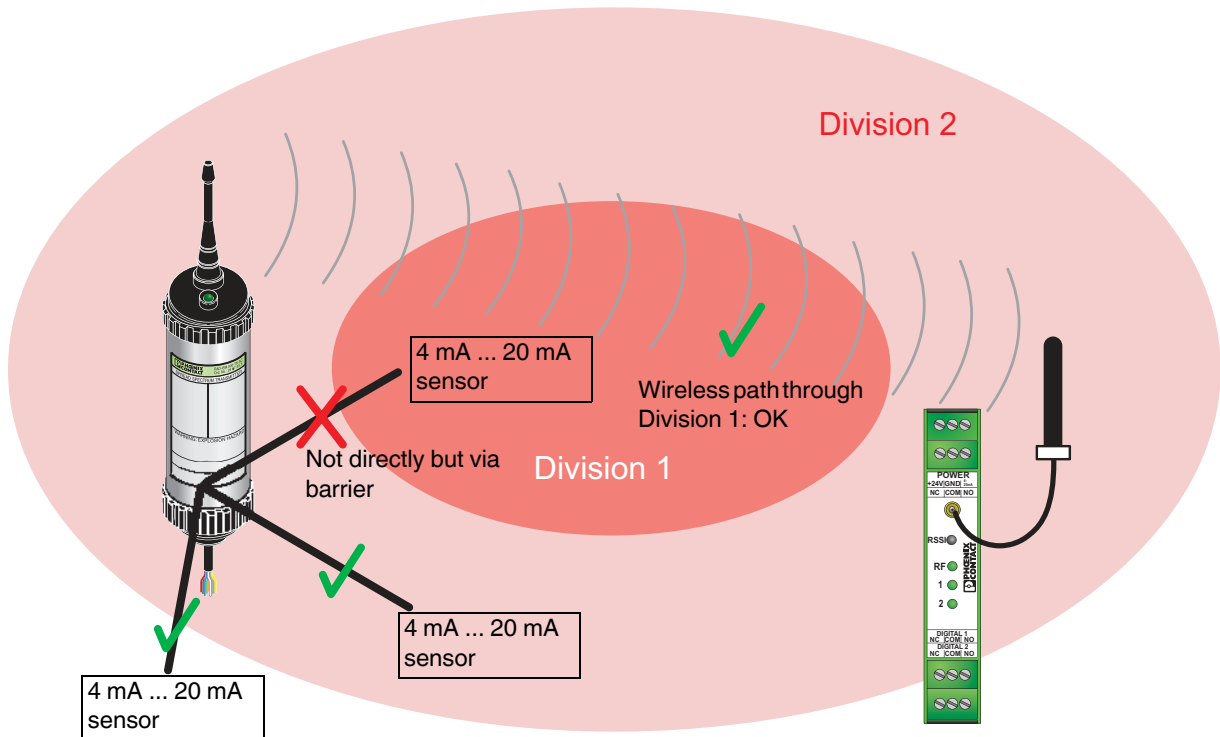

Figure 23 Typical usage in Class I, Division 2

6.7 Additional receivers

To add additional receivers, see “Additional receivers” on page 12.

7 System Versions

7.1 Point-to-point

In a point-to-point system, the set is installed, the signals are connected, and the operating voltage is applied. The wireless connection is established automatically - no other settings are required.

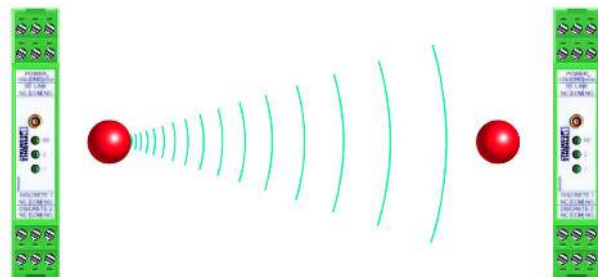

Figure 24 Point-to-point system

7.2 Point-to-multipoint

In a point-to-multipoint system, one of the following sets is installed first:

- RAD-ISM-900-SET-UD-ANT (Order No. 2867102)
- RAD-ISM-900-SET-AC-UD (Order No. 2867021)
- RAD-ISM-900-SET-DC-UD (Order No. 2867034)

The signals are connected and the operating voltage is applied. The wireless connection is established automatically.

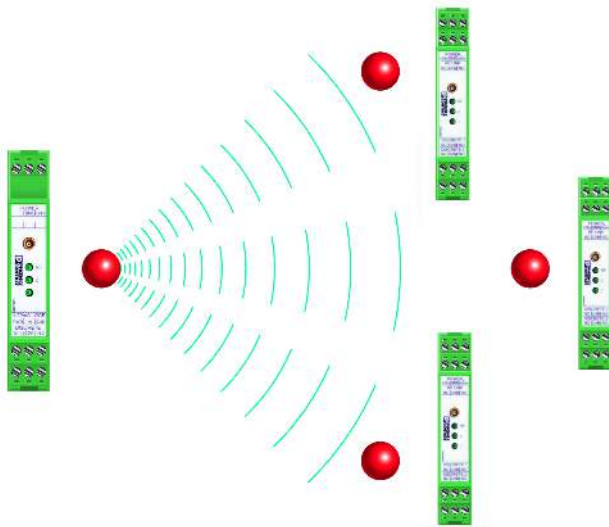

Figure 25 Point-to-multipoint system

Signal paths can be divided or multiplied by installing additional receivers.

- RAD-ISM-900-RX (Order No. 2867047)

For installation, see “Additional receivers” on page 12.

8 Autonomous Power Supply of Wireless Modules

Solar systems:

RAD-SOL-SET-... solar systems can be used in a wide range of global applications and are specifically designed to supply RAD-ISM-900-SET... wireless modules. The systems are designed in such a way that sufficient solar power is provided even on short winter days. The assembly material provided ensures a stable structure, which, depending on the installation location, can be used to align the solar cells with the relevant position of the sun. The solar systems can be mounted on standard masts with a diameter of 76 mm.

The RAD-SOL-SET-24-100 (Order No. 5605943) can be used to power any of the modules.

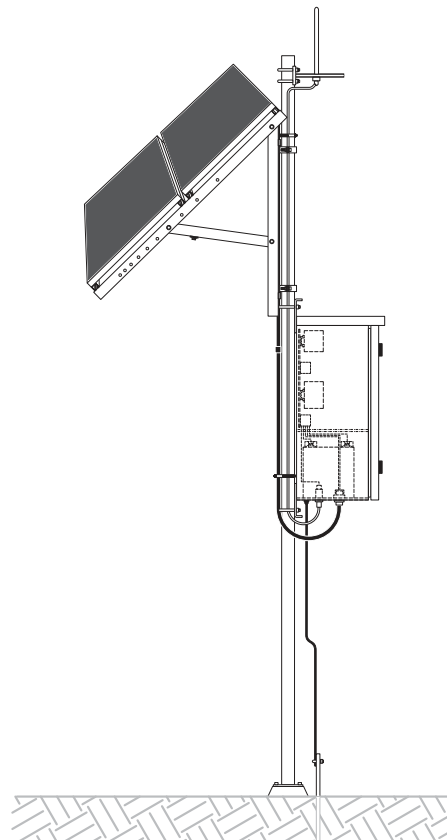

Figure 26 Typical solar system installation