

OPTION G

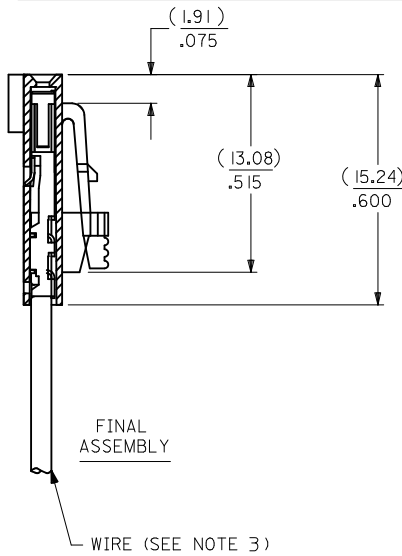
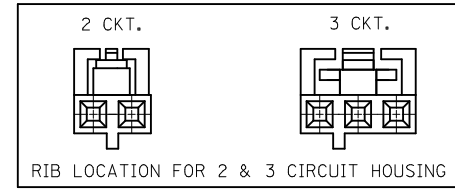
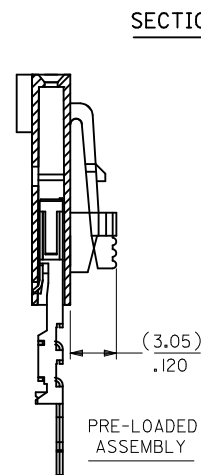
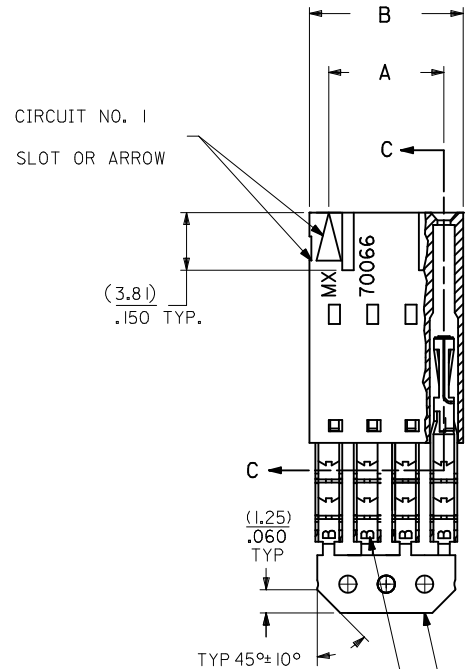
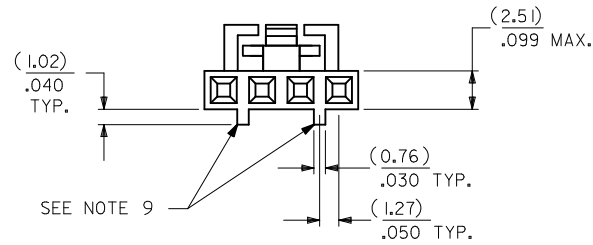

- NOTES:
 1. MATERIAL:
 HOUSING: POLYESTER(PBT), GLASS FILLED, UL94 V-0,
 COLOR: BLACK
 TERMINAL: PHOSPHOR BRONZE
 2. FINISH:
 15 GOLD: 0.38 MICROMETERS/15 MICROINCHES MINIMUM GOLD IN
 1.91 MICROMETERS/75 MICROINCHES MINIMUM TIN
 OVER NICKEL UNDERPLATE OVERALL
 3. TO BE USED WITH 26 AWG STRANDED WIRE WITH (1.35)/.053
 DIAMETER MAXIMUM INSULATION
 4. SEE TABLE FOR AVAILABLE CIRCUIT SIZES
 5. STANDARD PACKAGING PER PK-70873-0001. OPTIONAL PACKAGING
 MAY BE AVAILABLE, REQUEST DRAWING PK-70400
 6. PARTS STACKABLE END TO END ON (2.54)/.100 CENTERS
 7. PRODUCT SPECIFICATION: PS-70400
 8. SEE DRAWING SDA-70400-**** (SHEET 3) FOR OPTIONAL
 HOUSING DETAILS
 9. 4 CIRCUIT SHOWN. 3-25 CIRCUITS HAVE 2 RIBS
 10. TO MATE WITH MOLEX PART NUMBERS: A-70373-****,
 A-70375-****, A-70389-****, A-70391-****,
 A-70107-****, A-70018-****, A-70543-****,
 A-70553-****, A-70541-****, A-70551-****,
 A-70545-****, A-70555-****
 11. 2 CIRCUIT ASSEMBLIES SUPPLIED AS GROUPED PAIRS

CKT. SIZE	A	B	EDP. NO.
2	(2.54) .100	(5.05) .199	14-56-2024
3	(5.08) .200	(7.59) .299	14-56-2034
4	(7.62) .300	(10.13) .399	14-56-2044
5	(10.16) .400	(12.67) .499	14-56-2054
6	(12.70) .500	(15.21) .599	14-56-2064
7	(15.24) .600	(17.75) .699	14-56-2074
8	(17.78) .700	(20.29) .799	14-56-2084
9	(20.32) .800	(22.83) .899	14-56-2094
10	(22.86) .900	(25.37) .999	14-56-2104
11	(25.54) 1.000	(27.91) 1.099	14-56-2114
12	(27.94) 1.100	(30.45) 1.199	14-56-2124
13	(30.48) 1.200	(32.99) 1.299	14-56-2134
14	(33.02) 1.300	(35.53) 1.399	14-56-2144
15	(35.56) 1.400	(38.07) 1.499	14-56-2154
16	(38.01) 1.500	(40.61) 1.599	14-56-2164
17	(40.64) 1.600	(43.15) 1.699	14-56-2174
18	(43.18) 1.700	(45.69) 1.799	14-56-2184
19	(45.72) 1.800	(48.23) 1.899	14-56-2194
20	(48.26) 1.900	(50.77) 1.999	14-56-2204
21	(50.80) 2.000	(53.31) 2.099	14-56-2214
22	(53.34) 2.100	(55.85) 2.199	14-56-2224
23	(55.88) 2.200	(58.39) 2.299	14-56-2234
24	(58.42) 2.300	(60.93) 2.399	14-56-2244
25	(60.96) 2.400	(63.47) 2.499	14-56-2254

I.D. SLOT CODE TO WIRE GAUGE CHART	
I.D. SLOT CODE	WIRE GAUGE
B	26 AWG.

PLATING CODE (STRIPE ON CARRIER STRIP)	
PLATING	COLOR
15 GOLD	YELLOW

REMOVE ENG NO. EC NO: UCP2011-110 DRW:MSI BARRA 2010/10/19 CHK:DJMORGAN 2010/10/19 APPR:SMILLER 2010/11/24	QUALITY SYMBOLS ▽=0 ▽=0 ▽=0	GENERAL TOLERANCES (UNLESS SPECIFIED) mm INCH 4 PLACES ± --- ± --- 3 PLACES ± --- ± .010 2 PLACES ± 0.25 ± .014 1 PLACE ± 0.35 ± --- ANGULAR ±1/2°	DIMENSION STYLE MM/IN	SCALE INCH	DESIGN UNITS INCH	THIRD ANGLE PROJECTION	
			DRAWN BY MSI BARRA	DATE 2010/10/19	CHECKED BY WAZ	DATE 1984/10/10	APPROVED BY SMILLER
DRAFT WHERE APPLICABLE MUST REMAIN WITHIN DIMENSIONS		MATERIAL NO. SEE TABLE	DOCUMENT NO. SDA-70400-0841-0864	MOLEX INCORPORATED			SHEET NO. 1 OF 1