

IML M22 panel mount LED multi colour beacon

- Ø 65 mm panel-mount LED multi-colour steady beacon
- RED, YELLOW or GREEN, can be switched externally
- High degree of protection IP 67
- Prewired with 1 m UL cable
- Modern LED technology and electronics
- Good signalling effect
- For industrial and general applications
- Panel size Ø 22.5 mm/M22
- Adapter available for M30.5 mm panel size



TECHNICAL DATA

Housing	Ø 65 mm, Polycarbonate black (RAL 9005) or grey (RAL 7035)
Lens	Polycarbonate, ribbed inside clear
Type of mounting	any
Panel size	22x1,25 mm (M22) and 30.5 mm (with adapter), mounting depth 34 mm
Cable entry	pre-wired (1 m cable)
Leakage current	0,003 A (PLC-suitable)
Beacon type	LED steady beacon - 3 colour beacon
Light source	12 LEDs
Number of colours	3
Duty cycle	100% (one colour)
Service life	Light source: 100.000 h
Operating temperature	-25°C/+50°C
Degree of protection	IP67 & UL Type 4/4x/13
Weight	117 g

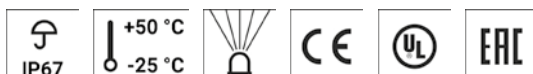
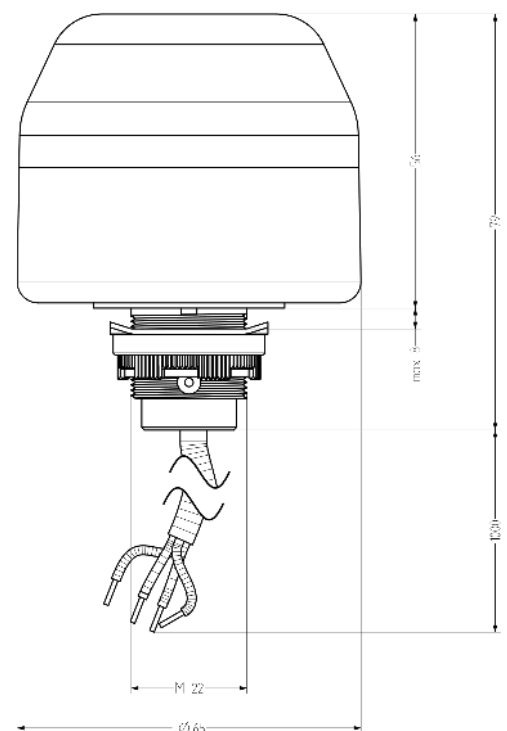

IML

ORDER DATA

Lens colour	Nominal voltage	Voltage range (V)	Nominal current (A)	Housing colour	
				grey	black
clear	24 V AC/DC	+/- 10 %	0,043	802 150 405	802 550 405
	110-120 V AC	+/- 10 %	0,033	802 150 310	802 550 310
	230-240 V AC	+/- 10 %	0,033	802 150 313	802 550 313



ADM30

ACCESSORIES

Type	Type of accessory	Weight	Order number
ADM30	Adapter for M30.5 for 30.5 mm holes	8 g	812 500 900