

THIS DRAWING IS UNPUBLISHED. RELEASED FOR PUBLICATION  
 © COPYRIGHT BY TYCO ELECTRONICS CORPORATION. ALL RIGHTS RESERVED.

LOC		DIST		REVISIONS			
P	LTR	DESCRIPTION		DATE	DWN	APVD	
	A1	REVISED PER ECR-08-019368		08AUG08	HMR	KR	

- 1 CONTINUOUS STRIP ON REELS WITH TERMINALS LOCATED ON 13.97±0.08 [.550±.003] CENTERS.
- 2 SLOT TERMINATES A SINGLE 0.8-0.9mm<sup>2</sup> [#18] AWG TIN PLATED SOLID, FUSED STRANDED OR STRANDED (7, 16, OR 19 STRANDS) WIRE WITH PET INSULATION, 2.03[.080] MAX DIA.
- 3 SLOT ACCEPTS 0.64mm [#22] AWG ALUMINUM MAGNET WIRE. SINGLE OR DOUBLE WIRE OF THE SAME SIZE AND TYPE.
- 4 SLOT ACCEPTS 0.81mm [#20] AWG ALUMINUM MAGNET WIRE. 2 WIRES OF THE SAME SIZE AND TYPE PER SLOT.
- 5 MTA PRODUCT SPEC IS 108-1051  
MAG-MATE PRODUCT SPEC IS 108-2012
- 6 MAG-MATE APPLICATION SPEC IS 114-2046  
MTA APPLICATION SPEC IS 114-1020
- 7 TERMINALS ARE STRESS RELIEVED

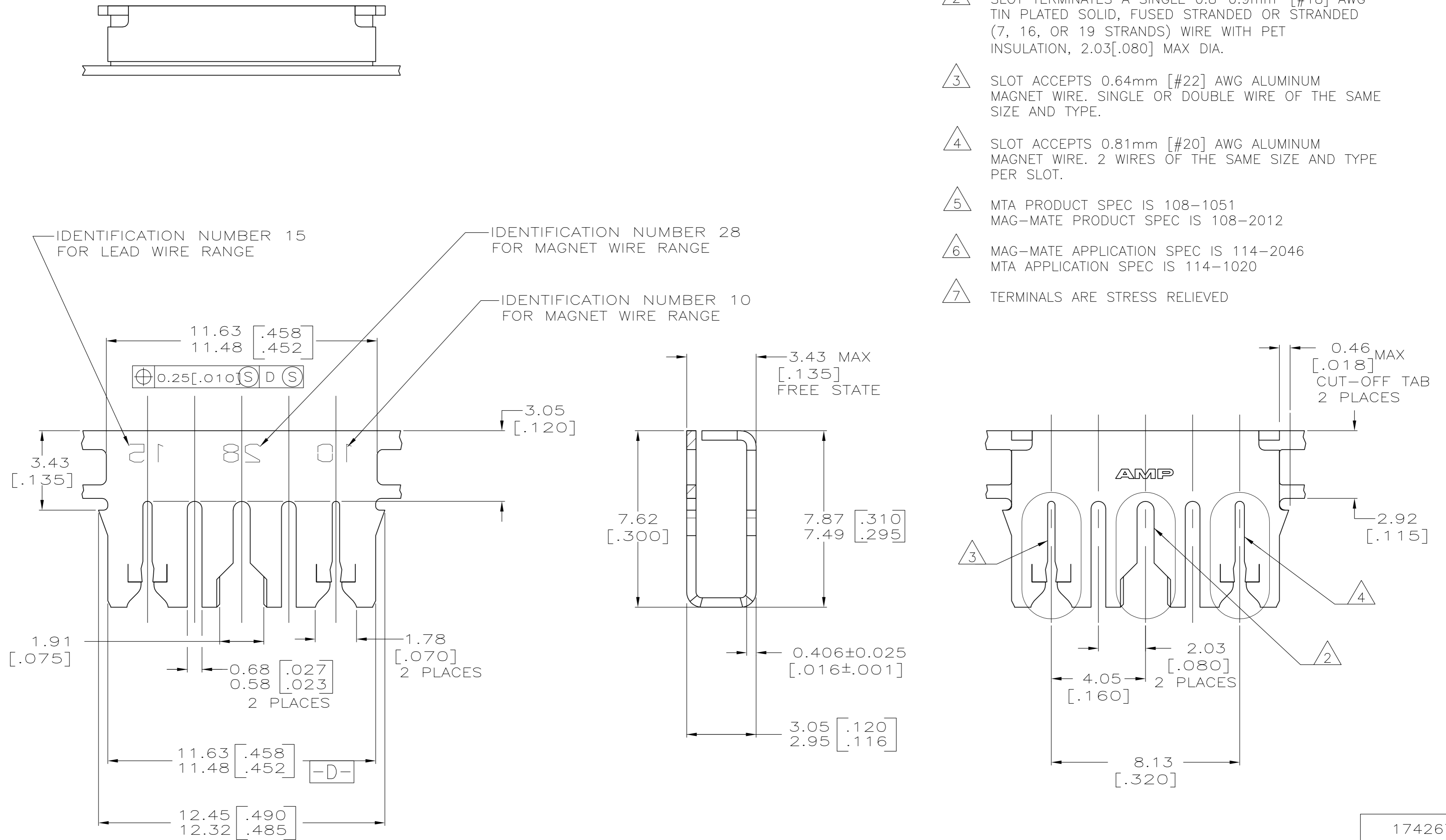

1742676

1742676-1  
 PART NUMBER

THIS DRAWING IS A CONTROLLED DOCUMENT.		DWN	JR RUTH	13FEB08	Tyco Electronics Corporation Harrisburg, Pa 17105-3608		
DIMENSIONS: mm [INCHES]		CHK	KURT A. RANDOLPH	13FEB08	NAME		
TOLERANCES UNLESS OTHERWISE SPECIFIED:		APVD	KURT A. RANDOLPH	13FEB08	TERMINAL, SPLICE, TRI-SLOT, 300 SERIES, MTA/MAG-MATE		
0 PLC	± -	PRODUCT SPEC	5	SIZE	CAGE CODE	DRAWING NO	RESTRICTED TO
1 PLC	± -	APPLICATION SPEC	6	A2	00779	C=1742676	-
2 PLC	± 0.25 [.010]	96-1039-143		SCALE	8:1	SHEET	1 OF 1
3 PLC	± -			REV	A1		
4 PLC	± -						
ANGLES	± -						
MATERIAL	4M BRASS	FINISH	0.002032 [.000080] MIN TIN PLATE	WEIGHT	-	CUSTOMER DRAWING	