

NOTE: (A4)

SUITABLE FOR RT360 SERIES 1403 LAYOUT WITHOUT "EC"  
PART NUMBER CONNECTOR

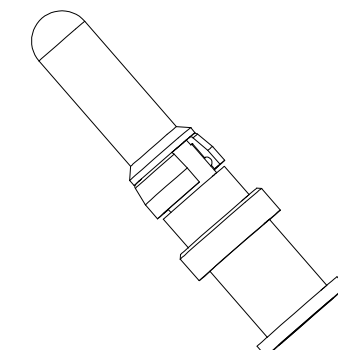
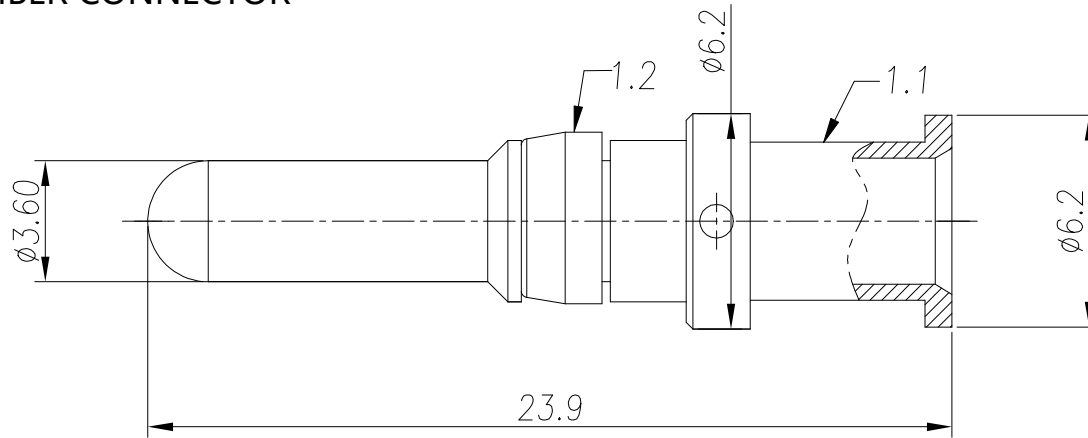

REVISIONS					
REV	ECO	DESCRIPTION	DATE	BY	APPR
A1	-	RELEASED DRAWING	Jan-17-2018	Nick	TOMMY
A2	-	UPDATE DRAWING	Jan-19-2018	Nick	TOMMY
A3	-	UPDATE DRAWING	Aug-06-2019	Ronald	Tommy
A4	-	Add the note	Sep-14-21	Flan	Tommy

NOTES: (UNLESS OTHERWISE SPECIFIED)

1. MATERIAL:
  - 1.1. CONTACT BODY: COPPER ALLOY.
  - 1.2. POSITIONING CLIP: COPPER ALLOY.
2. SPECIFICATIONS:
  - 2.1 CURRENT RATING: 45A(MAX).
  - 2.2 TERMINATION TYPE: CRIMPING.
  - 2.3 WIRE RANGE: SEE TABLE
3. SUITABLE CONTACT: MS10A23\*-25 & MS10A23\*-63.
4. RoHS COMPLIANT.
5. ALL DIMENSIONS ARE FOR REFERENCE USE ONLY.

P/N	WIRE RANGE	CONTACT PLATING(MATING AREA)
MP10A23S-25	1.5~2.5mm <sup>2</sup>	SILVER PLATING OVER NICKEL.
MP10A23F-25	1.5~2.5mm <sup>2</sup>	GOLD FLASH PLATING OVER NICKEL.
MP10A23S-63	4~6mm <sup>2</sup>	SILVER PLATING OVER NICKEL.
MP10A23F-63	4~6mm <sup>2</sup>	GOLD FLASH PLATING OVER NICKEL.

QUANTITY	PART NUMBER	DESCRIPTION	ITEM								
<b>MATERIALS LIST</b>											
<small>UNLESS OTHERWISE SPECIFIED</small> 1) All dimensions are in metric(mm). 2) Tolerances are as follows: 1 PL DEC ±0.30 2 PL DEC ±0.15 3 PL DEC ±0.08 Fractions ±1/64 Angles ±1° 3) Note reference =		<b>SIGNATURES</b> <b>DATE</b> DRAWN: <u>Flan</u> <u>Sep-14-21</u> CHECKED: <u>Orion</u> <u>Sep-15-21</u> ENGINEER: APPROVAL: <u>Tommy</u> <u>Sep-15-21</u> CUSTOMER:	 Sine Systems - www.amphenol-sine.com 44724 Morley Drive Clinton Township, MI 48036								
MATERIAL SPECIFICATIONS: PROCESS SPECIFICATIONS: NEXT ASSY:		THIS DRAWING IS SUPPLIED FOR INFORMATION ONLY. DESIGN FEATURES, SPECIFICATIONS AND PERFORMANCE DATA SHOWN HEREON ARE THE PROPERTY OF THE AMPHENOL CORPORATION. NO RIGHTS OF REPRODUCTION ARE IMPLIED. ALL DIMENSIONS ARE SUBJECT TO NORMAL MANUFACTURING VARIATIONS.	EcoMate RM,PIN CONTACT MACHINE, 8# (Ø3.6mm)  <table border="1"> <tr> <td>SIZE</td> <td>TYPE</td> <td>DWG NO.</td> <td>REVISION</td> </tr> <tr> <td>B</td> <td>C-</td> <td>MP10A23*-25/63</td> <td>A4</td> </tr> </table>	SIZE	TYPE	DWG NO.	REVISION	B	C-	MP10A23*-25/63	A4
SIZE	TYPE	DWG NO.	REVISION								
B	C-	MP10A23*-25/63	A4								
SCALE: NONE		SHEET 1 OF 1									

TITLE: EcoMate RM,PIN CONTACT MACHINE, 8# (Ø3.6mm)  
 DWG NO.: MP10A23\*-25/63  
 REV: A4  
 SH: 1  
 OF: 1