

DESCRIPTION

The EV2009EE-00A evaluation board demonstrates the performance of MP2009, an ultra low noise, low dropout linear regulator. It operates from a 2V to 6V input voltage and regulates the output voltage range from 1.5V to 4.5V in 100mV increments.

The EV2009EE-00A can supply up to 120mA of load current with a typical dropout voltage of 172 mV. It provides thermal overload and current limit protection, stability with ultra low ESR ceramic capacitors as low as 1uF, and very fast transient response.

ELECTRICAL SPECIFICATIONS

Parameter	Symbol	Value	Units
Input Voltage	V_{IN}	2.3 – 6.0	V
Output Voltage	V_{OUT1}	1.8	V
Operating Temperature		-20 – +85	°C

FEATURES

- Wide 2V to 5V Input Voltage Range
- Fixed Output Voltage range from 1.5V to 4.5V in 100mV increments
- $16\mu V_{RMS}$ Output Noise at 100Hz to 100kHz Bandwidth with No Bypass Capacitor required
- 78dB PSRR at 1kHz
- 172mV Dropout at 120mA Load
- Stable with $1\mu F$ Ceramic Capacitor for Any Load
- Low $50\mu A$ Ground Current
- Very Fast Line and Load Transient Response with Small Input and Output Capacitor
- Current Limit and Thermal Protection

APPLICATIONS

- Cellular and Cordless Phones
- VCOs
- PDA and Palmtop Computers
- Digital Cameras
- Base Stations
- Wireless LANs
- Personal Stereos
- Bluetooth Portable Radios and Accessories
- Portable and Battery-Powered Equipment

MPS[®] and "The Future of Analog IC Technology" are Registered Trademarks of Monolithic Power Systems, Inc.

EV2009EE-00A EVALUATION BOARD



(L x W x H) 2.5" x 2.5" x 0.4"
(6.3cm x 6.3cm x 1.1cm)

Board Number	MPS IC Number
EV2009EE-00A	MP2009EE-1.8

EVALUATION BOARD SCHEMATIC

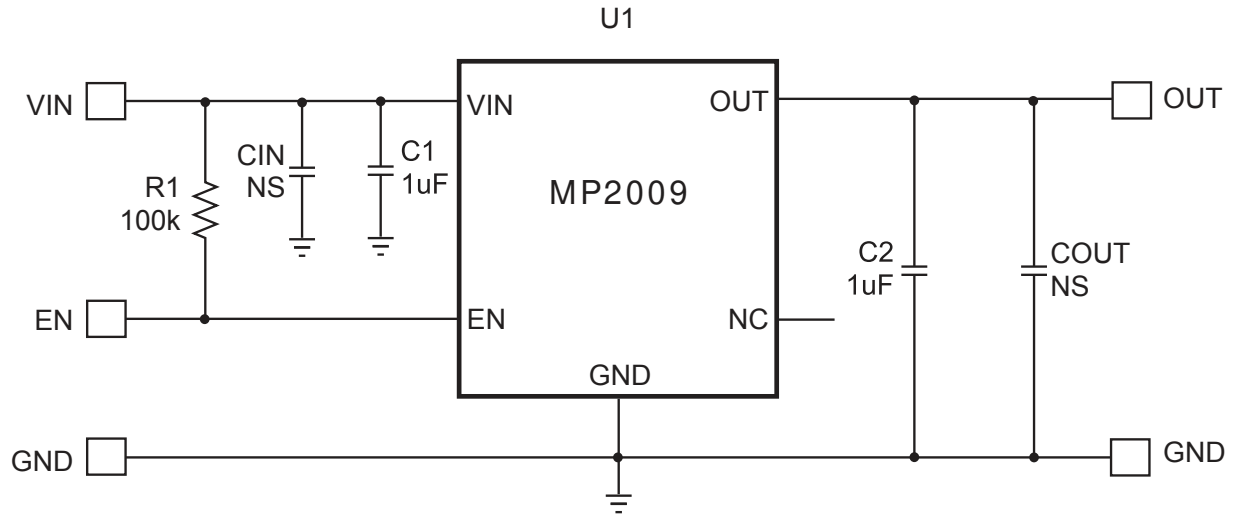

EV2009EE-00A BILL OF MATERIALS

Qty	Ref	Value	Description	Package	Manufacturer	Part Number
2	C1, C2	1uF	Ceramic Capacitor, X7R, 16V	0603	TDK	C1608X7R1C105K
2	CIN, COUT	NS				
1	R1	100K	Film Res, 5%	0603	Any	
1	U1		LDO Regulator	5-SC70	MPS	MP2009EE-1.8

PRINTED CIRCUIT BOARD LAYOUT

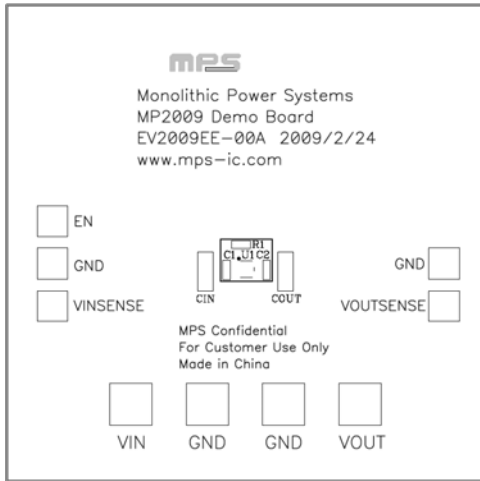

Figure 1—Top Silk Layer

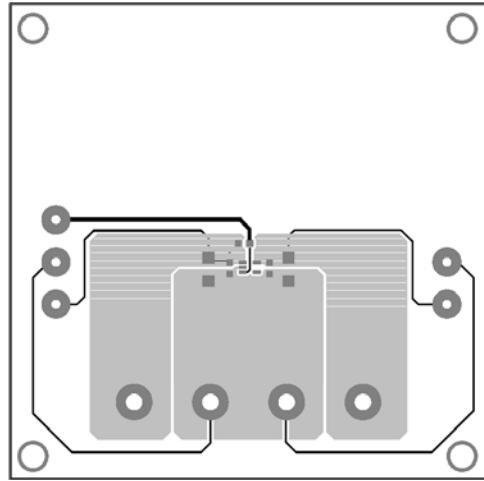

Figure 2—Top Layer

QUICK START GUIDE

The output voltage of this board is preset to 1.8V. The EN pin is connected to V_{IN} with a 100k Ω resistor for automatic startup. You can connect EN to GND to disable the MP2009.

1. Attach the positive and negative ends of the load to the VOUT and GND pins, respectively.
2. Attach the input voltage ($2.3V \leq V_{IN} \leq 6V$) and input ground to the V_{IN} and GND pins, respectively.

NOTICE: The information in this document is subject to change without notice. Please contact MPS for current specifications. Users should warrant and guarantee that third party Intellectual Property rights are not infringed upon when integrating MPS products into any application. MPS will not assume any legal responsibility for any said applications.