



MIC2297 Evaluation Board

600kHz 42V OVP PWM White LED Driver

General Description

The MIC2297 is a 600kHz PWM White LED Driver optimized for 6 to 10 series WLEDs. With an output voltage of up to 42V and a guaranteed 1.2A on the internal power switch, the MIC2297 can easily drive 10 WLEDs at 20mA continuous current. The MIC2297 features WLED brightness control using the BRT pin and has output over voltage protection (OVP) to protect the device in case the WLEDs are disconnected unexpectedly. Available in a tiny 10-pin 2.5mm x 2.5mm x 0.85mm MLF[®] package, the MIC2297 solution only requires a total of 6 external components.

The MIC2297 operates at a default (BRT pin is open) feedback voltage of only 200mV. The low feedback voltage reduces the power dissipation from the external current set resistor and increases total operating efficiency.

When brightness control is required, the MIC2297 features brightness control by applying a DC voltage to the BRT pin. When applying a DC voltage to the BRT pin, the feedback voltage is equal to the BRT voltage divided by 5. This feature essentially increases or decreases the feedback voltage from its default value (200mV), changing the WLED current to control the WLED brightness.

Alternatively, a PWM signal may also be applied to the BRT pin for brightness control. When a PWM signal (1kHz recommended) is applied to the BRT pin, the WLEDs are dimmed depending on the duty cycle and the peak voltage of the signal. The PWM frequency can range from 1kHz to 1MHz. The selected PWM frequency does not affect the WLED brightness. Assuming a 1V PWM signal is applied, as the duty cycle decreases, the feedback voltage decreases, thus reducing the WLED current.

Requirements

The MIC2297 evaluation board requires an input power source that is capable of delivering greater than 1.2A at 2.5V.

Precautions

The evaluation board does not have reverse polarity protection. Applying a negative voltage to the V_{IN} terminal may damage the device.

The MIC2297 evaluation board is tailored for a single or dual Li-Ion input source. The input voltage should never exceed 10V.

Getting Started

- Connect an external supply to V_{IN} .** Apply desired input voltage to the V_{IN} (J1) and ground (J4) terminals of the evaluation board, paying careful attention to polarity and supply voltage ($2.5V \leq V_{IN} \leq 10V$). An ammeter may be placed between the input supply and the V_{IN} (J1) terminal to the evaluation board to accurately monitor the input current. The ammeter and/or power lead resistance can reduce the voltage supplied to the input; therefore, the supply voltage at the V_{IN} (J1) terminal should be monitored.
- Enable/Disable the MIC2297.** To enable the MIC2297, apply a 1.5V or greater voltage signal to the EN (J2) terminal. To disable the device, pull the EN (J2) pin below 0.4V. The evaluation board is configured with a jumper (JP1) from V_{IN} to the enable pin and a 10k pull-down resistor to ground to conveniently turn the part on or off. Connecting the jumper (JP1) will enable the MIC2297, while removing the jumper will disable the part.
- DCV Brightness Control.** To control the brightness with a DC voltage, see the DVC Brightness Control section.
- PWM Brightness Control.** To control the brightness with a PWM Signal, see the PWM Brightness Control section.

Note: For detailed specifications, please refer to the MIC2297 Datasheet at www.micrel.com.

Ordering Information

Part Number	Description
MIC2297-42YML EV	Evaluation board with the MIC2297 42V device

MLF and *MicroLeadFrame* are registered trademarks of Amkor Technology, Inc.

Micrel Inc. • 2180 Fortune Drive • San Jose, CA 95131 • USA • tel +1 (408) 944-0800 • fax + 1 (408) 474-1000 • <http://www.micrel.com>

LED Current Setting

There are 10 WLEDs provided with the evaluation board. Two of the WLEDs (D1 and D2) may be by-passed by placing a jumper on JP3. The WLED current (I_{LED}) is equal to the feedback voltage ($V_{FB} = 200mV$ by default) divided by the R3 resistance value. The evaluation board is provided with R3 equal to 10Ω . The brightness level is proportional to I_{LED} . Programming the feedback voltage changes the I_{LED} , therefore changing the brightness level.

$$I_{LED} = V_{FB} / R3 \tag{1}$$

DCV Brightness Control

The brightness level can be set by applying a DC voltage (BRT) to the BRT pin. When a DC voltage is applied to the BRT pin, the feedback voltage is changed from the default value of 200mV to:

$$V_{FB} = BRT / 5 \tag{2}$$

Assuming BRT equals 1V, then V_{FB} will be 200mV and I_{LED} may be calculated by:

$$I_{LED} = V_{FB} / R3$$

$$I_{LED} = 200mV / 10\Omega$$

$$I_{LED} = 20mA$$

Similarly, if BRT equals 2V, then V_{FB} will be 400mV and the I_{LED} may be calculated by:

$$I_{LED} = V_{FB} / R3$$

$$I_{LED} = 400mV / 10\Omega$$

$$I_{LED} = 40mA$$

The feedback voltage can be changed using the BRT pin. Changing the feedback voltage changes the WLED current, which will change the WLED brightness. Refer to the Figure 1 and Figure 2 for reference.

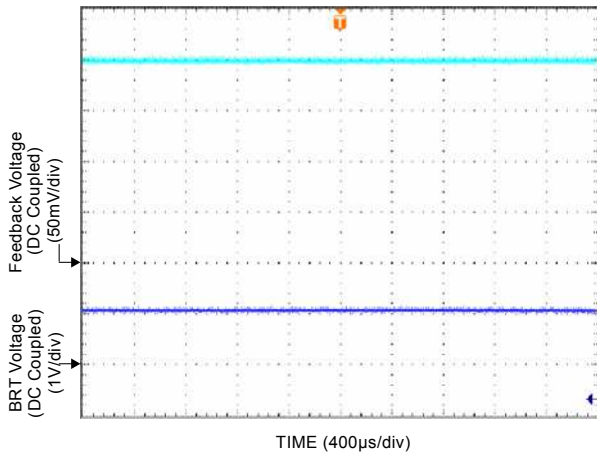

Figure 1. BRT = 1V, $V_{FB} = 200mV$, $I_{LED} = 20mA$

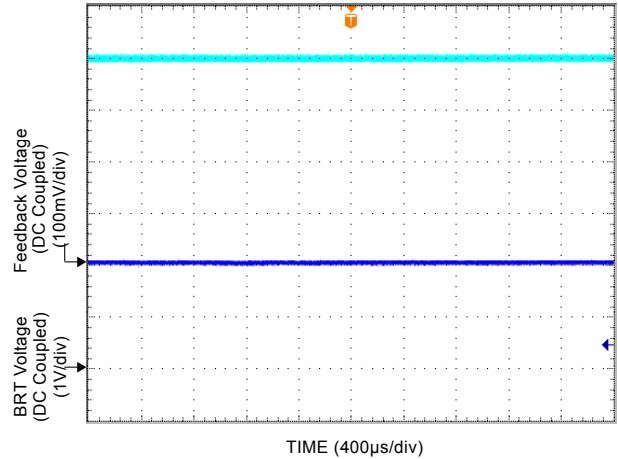

Figure 2. BRT = 2V, $V_{FB} = 400mV$, $I_{LED} = 40mA$

PWM Brightness Control

The brightness level can also be set by applying a PWM signal to the BRT pin. To calculate the feedback voltage when a PWM signal is applied to the BRT pin, use the following formula:

$$V_{FB} = V_{PEAK} / 5 * D \tag{3}$$

V_{PEAK} is the peak of the PWM voltage and D is the duty cycle. If V_{PEAK} is 1V and the duty cycle is 1%, then V_{FB} can be calculated by:

$$V_{FB} = 1V / 5 * 0.01$$

$$V_{FB} = 2mV$$

The I_{LED} can then be calculated by:

$$I_{LED} = V_{FB} / R3$$

$$I_{LED} = 2mV / 10\Omega$$

$$I_{LED} = 200\mu A$$

Similarly, if the V_{PEAK} is 1V and the duty cycle is 50%, then V_{FB} can be calculated by:

$$V_{FB} = 1V / 5 * 0.5$$

$$V_{FB} = 100mV$$

The I_{LED} can then be calculated by:

$$I_{LED} = V_{FB} / R3$$

$$I_{LED} = 100mV / 10\Omega$$

$$I_{LED} = 10mA$$

With PWM brightness control, the MIC2297 has great versatility since brightness may be set anywhere from 0 to 100 percent. Refer to the following figures for reference.

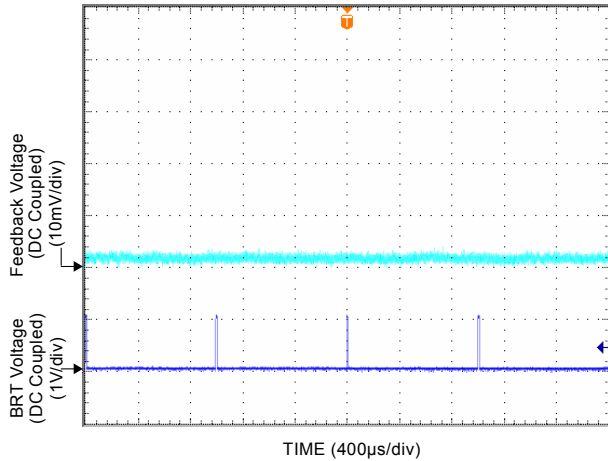

Figure 3. Duty Cycle = 1%, $V_{FB} = 2mV$, $I_{LED} = 200\mu A$

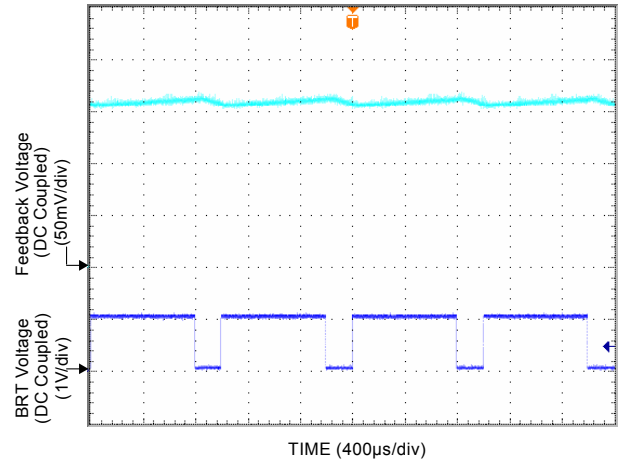

Figure 6. Duty Cycle = 80%, $V_{FB} = 160mV$, $I_{LED} = 16mA$

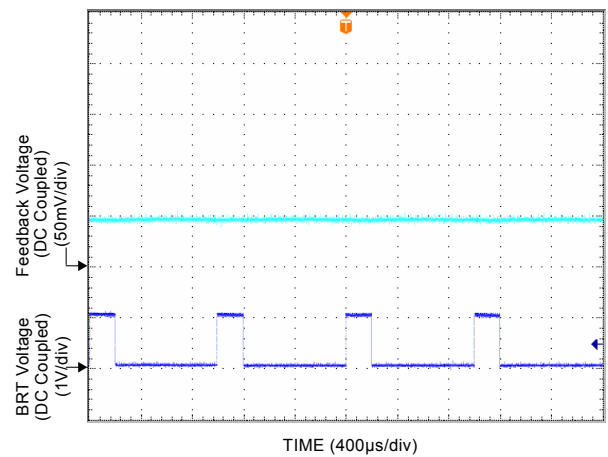

Figure 4. Duty Cycle = 20%, $V_{FB} = 40mV$, $I_{LED} = 4mA$

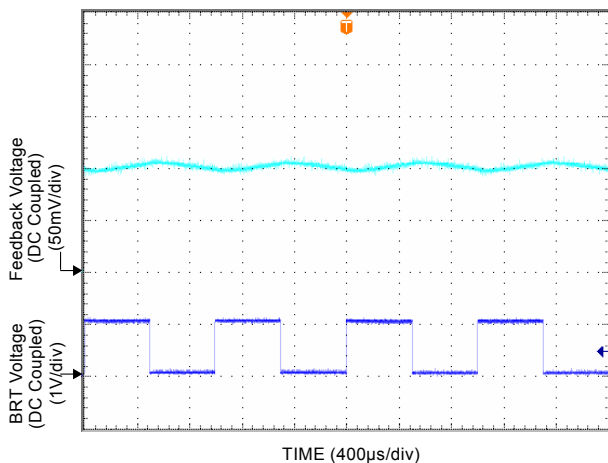

Figure 5. Duty Cycle = 50%, $V_{FB} = 100mV$, $I_{LED} = 10mA$

In Figure 7, when the duty cycle is equal to 100%, D equals 1. When we set D equal to 1 in equation (3), notice (3) becomes the same as equation (2), if we assume V_{PEAK} equals BRT. Using a 100% duty cycle is the same as applying a constant DC voltage to the BRT pin. In this instance, Figure 7 is exactly the same as Figure 1.

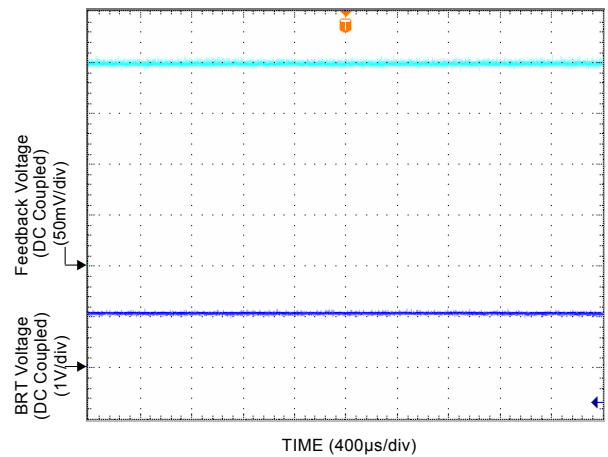
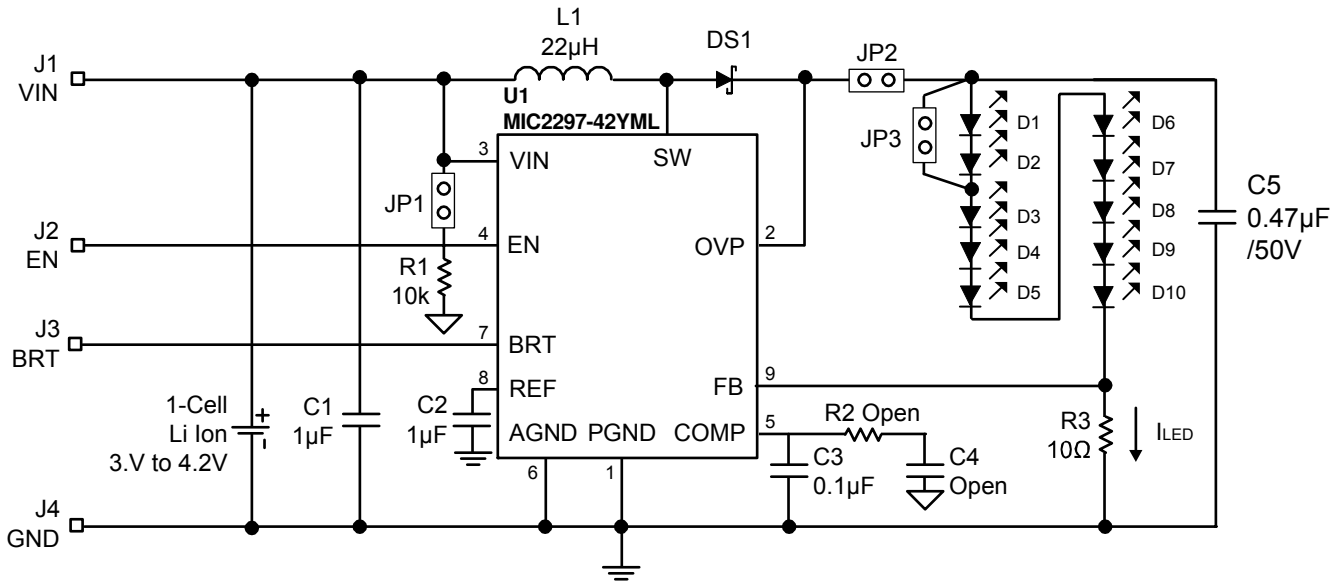

Figure 7. Duty Cycle = 100%, $V_{FB} = 200mV$, $I_{LED} = 20mA$

Typical Application Circuit



10 LED Configuration

Bill of Materials

Item	Part Number	Manufacturer	Description	Qty
C1, C2	C1608X5R1A105K	TDK ⁽¹⁾	1µF Ceramic Capacitor, 10V, X5R, Size 0603	2
C3	VJ0603Y104KXXAT	Vishay ⁽²⁾	0.1µF Ceramic Capacitor, 25V, X7R, Size 0603	1
C4				Open
C5	C2012X7R1H474M	TDK ⁽¹⁾	0.47µF Ceramic Capacitor, 50V, X7R, Size 0805	1
DS1	DFLS160-7	Diodes Inc ⁽³⁾	1A, 60V, Schottky Diode	1
L1	LQH43CN220K01L	Murata ⁽⁴⁾	22µH, 420mA I _{SAT.} , 120mΩ, (4.5mm × 3.2mm × 2.6mm)	1
	MLP3225S100L	TDK ⁽¹⁾	10µH, 1000mA I _{SAT.} , 130mΩ, (3.2mm × 2.5mm × 1mm)	
	LPS4012-223MLC	Coilcraft ⁽⁵⁾	22µH, 720mA I _{SAT.} , 600mΩ, (4.1mm × 4.1mm × 1.2mm)	
R1	CRCW06031002FRT1	Vishay ⁽²⁾	10KΩ, 1%, 1/16W, Size 0603	1
R2				Open
R3	CRCW060310R0FRT1	Vishay ⁽²⁾	10Ω, 1%, 1/16W, Size 0603	1
D1-D10	VLMW3100-5K8L-08	Vishay ⁽²⁾	20mA Standard SMD LED PLCC-2	10
U1	MIC2297-42YML	Micrel ⁽⁶⁾	600kHz 40V PWM White LED Driver	1

1. TDK: www.tdk.com

2. Vishay-Dale: www.vishay.com

3. Diodes Inc: www.diodes.com

4. Murata: www.murata.com

5. Coilcraft: www.coilcraft.com

6. **Micrel, Inc:** www.micrel.com

PCB Layout Recommendations

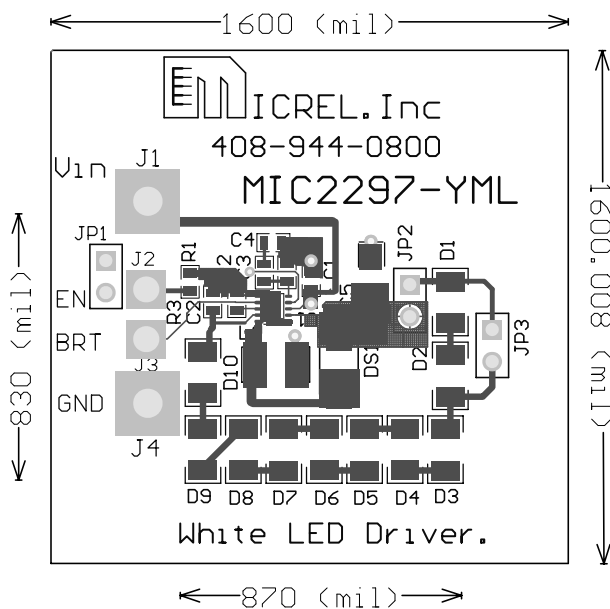

Top Layer

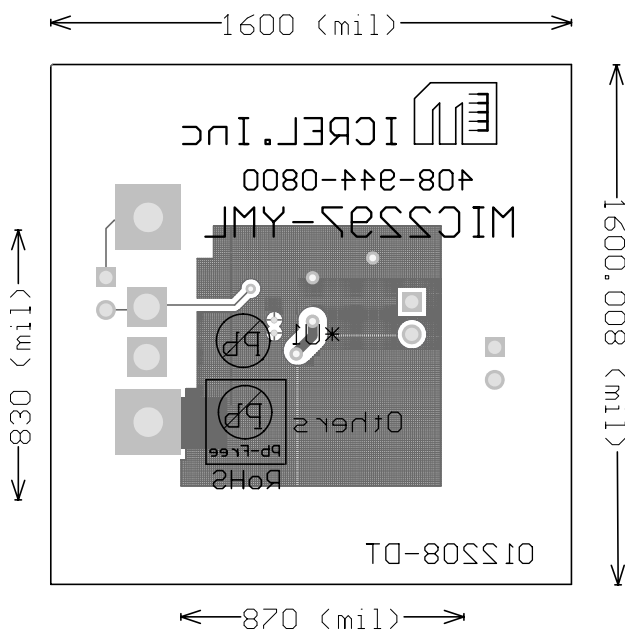

Bottom Layer

MICREL, INC. 2180 FORTUNE DRIVE SAN JOSE, CA 95131 USA
TEL +1 (408) 944-0800 FAX +1 (408) 474-1000 WEB <http://www.micrel.com>

The information furnished by Micrel in this data sheet is believed to be accurate and reliable. However, no responsibility is assumed by Micrel for its use. Micrel reserves the right to change circuitry and specifications at any time without notification to the customer.

Micrel Products are not designed or authorized for use as components in life support appliances, devices or systems where malfunction of a product can reasonably be expected to result in personal injury. Life support devices or systems are devices or systems that (a) are intended for surgical implant into the body or (b) support or sustain life, and whose failure to perform can be reasonably expected to result in a significant injury to the user. A Purchaser's use or sale of Micrel Products for use in life support appliances, devices or systems is a Purchaser's own risk and Purchaser agrees to fully indemnify Micrel for any damages resulting from such use or sale.

© 2008 Micrel, Incorporated.