

REVISIONS			
REV	DESCRIPTION, ECN, EAR NO.	DATE	APP'D
D	PRODUCT DRAWING (EAR 13700/13725)	JUN04/10	K.L

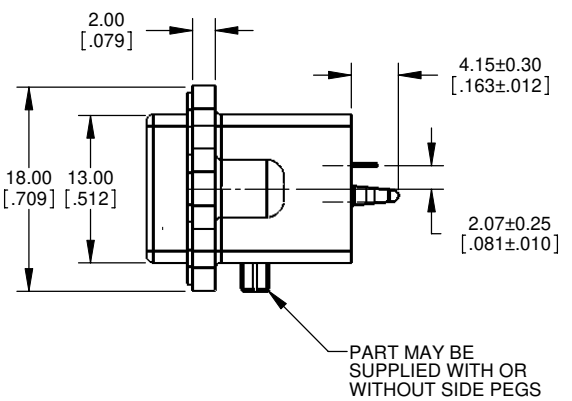
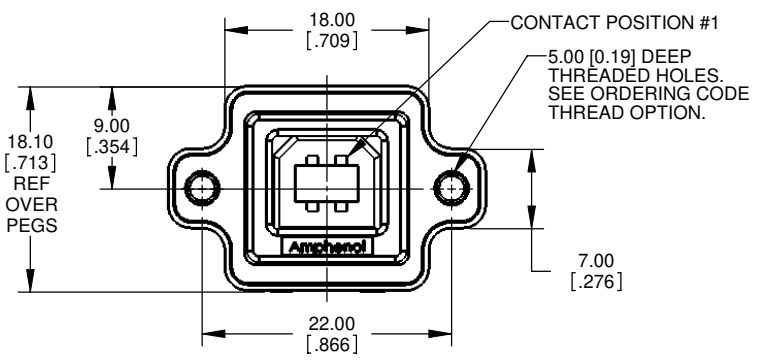

ORDERING CODE: M U S B - D 5 1 1 - X X

SERIES, RUGGED USB

USB SERIES 'B' RECEPTACLE, VERTICAL, PCB TAIL

THREAD OPTION  
 0=#4-40 UNC THREAD  
 N=M3 x 0.5 THREAD

DUST COVER OPTION  
 0=NO DUST COVER SUPPLIED  
 1=WITH GREY DUST COVER SUPPLIED  
 5=WITH BLACK DUST COVER SUPPLIED

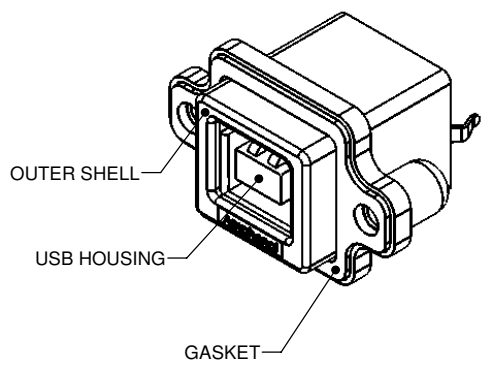
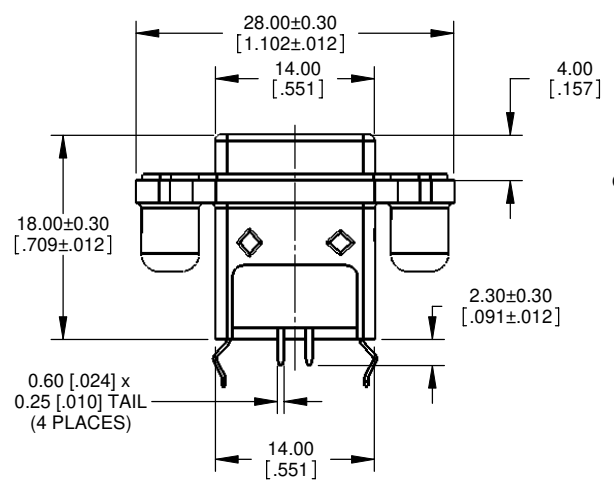

**NOTES:**

- MATERIAL:  
 ALL MATERIALS ARE RoHS COMPLIANT PER EU DIRECTIVE 2002/95/EC AND AMENDMENTS
  - SHELL - DIECAST ZINC, NICKEL PLATED
  - CONTACTS - COPPER ALLOY WITH 30 MICROINCHES (0.76 MICRONS) GOLD OVER 50 MICROINCHES (1.27 MICRONS) MINIMUM NICKEL ON THE MATING AREA AND TIN ON THE CONTACT TAILS.
  - INSERTS - ENGINEERING THERMOPLASTIC, UL FLAMMABILITY RATING 94V-0, COLOUR: WHITE
  - GASKET - SILICONE RUBBER
  - DUST COVER - SILICONE RUBBER WITH NICKEL PLATED, COPPER ALLOY BUSHING
- ENVIRONMENTAL PERFORMANCE PER IEC 60529 CODE IP67 FOR SEAL BETWEEN MATING AREA AND PCB SIDE OF CONNECTOR. GASKET PROVIDES SEAL TO INSIDE FACE OF PANEL.
- CURRENT RATING: 1.5 AMPERES
- CONTACT RESISTANCE: 30 MILLIOHMS MAXIMUM
- OPERATING TEMPERATURE: -40C TO +105C
- DUST COVERS MAY BE ORDERED SEPARATELY. SPECIFY
  - MUSB-2D11-004BP FOR GREY DUST COVER
  - MUSB-2D11-014BP FOR BLACK DUST COVER
 SEE SHEET 2 FOR APPLICATION VIEW

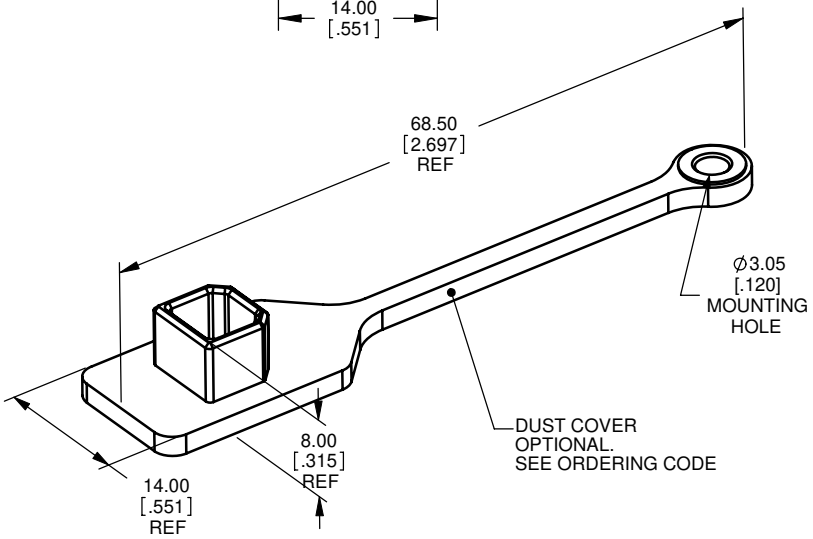

UNLESS SPECIFIED OTHERWISE	DRAWN	A.DODDS	JUL19/07
PRIMARY UNITS MILLIMETERS	CHECKED	K.LAMBIE	JUL20/07
SECONDARY MILLIMETERS	M.E. APP'D		
REFERENCE IN PARENTHESES	Q.A. APP'D		
GENERAL TOLERANCES	DWG APPR.		
1 DECIMAL PLACE	ENG. REL. NO.	EAR 13139	
2 DECIMAL PLACES ±0.20	REF.		
3 DECIMAL PLACES	THIRD ANGLE PROJECTION		
ANGULAR DEGREES	DO NOT SCALE DRAWING		

**Amphenol Canada Corp.**

MUSB SERIES RUGGED USB RECEPTACLE, SERIES 'B' INTERFACE, VERTICAL PCB MOUNT, RoHS COMPLIANT

DWG. NO. P-MUSB-D511-XX REV D

CODE ID NO. 03554 DWG SIZE: C SCALE: 3:1 SHEET 1 OF 2

REVISIONS			
REV	DESCRIPTION, ECN, EAR NO.	DATE	APP'D
D	PRODUCT DRAWING (EAR 13700/13725)	JUN04/10	KL

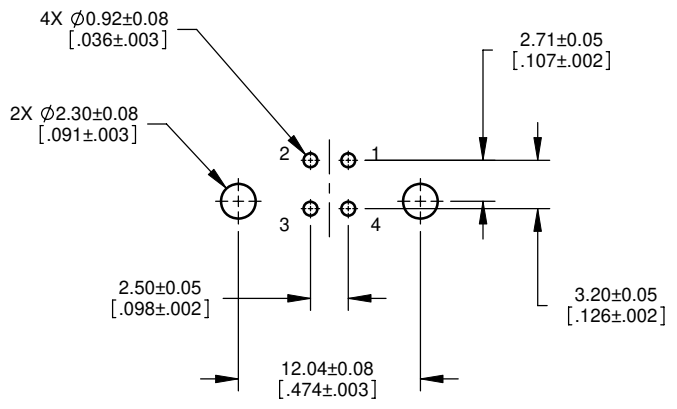

**RECOMMENDED P.C.B. LAYOUT**  
(COMPONENT SIDE OF BOARD)

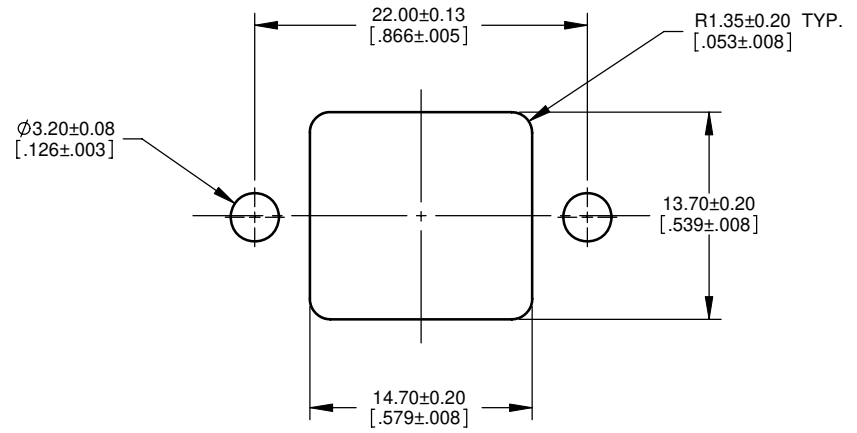

**RECOMMENDED PANEL CUTOUT**

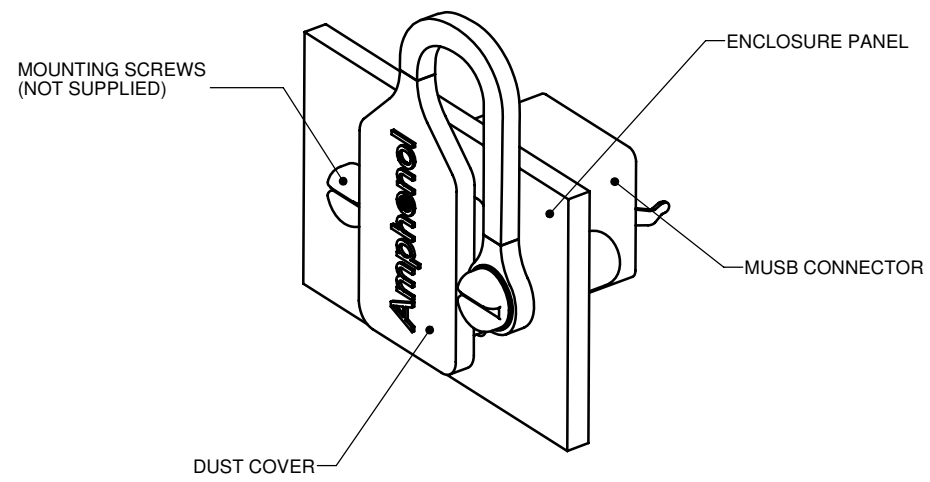

**DUST COVER APPLICATION**  
SCALE 3:1



UNLESS SPECIFIED OTHERWISE	DRAWN	A.DODDS	JUL19/07
PRIMARY UNITS MILLIMETERS	CHECKED	K.LAMBIE	JUL20/07
SECONDARY INCHES	M.E. APP'D		
REFERENCE IN PARENTHESES	Q.A. APP'D		
GENERAL TOLERANCES	DWG APPR.		
1 DECIMAL PLACE	ENG. REL. NO.	EAR 13139	
2 DECIMAL PLACES ±0.20	REF.		
3 DECIMAL PLACES	THIRD ANGLE PROJECTION		
ANGULAR DEGREES	DO NOT SCALE DRAWING		

<b>Amphenol Canada Corp.</b>	
MUSB SERIES RUGGED USB RECEPTACLE, SERIES 'B' INTERFACE, VERTICAL PCB MOUNT, RoHS COMPLIANT	
DWG. NO.	REV D
<b>P-MUSB-D511-XX</b>	
CODE ID NO. 03554	DWG SIZE: C
SCALE: 4:1	SHEET 2 OF 2

THIS DOCUMENT CONTAINS PROPRIETARY INFORMATION AND SUCH INFORMATION MAY NOT BE DISCLOSED TO OTHERS FOR ANY PURPOSE OR USED FOR MANUFACTURING PURPOSES WITHOUT WRITTEN PERMISSION FROM AMPHENOL CANADA CORP.