

REVISIONS			
REV	DESCRIPTION, EGN, EAR NO.	DATE	APP'D
A	PROPOSAL DRAWING (EAR 13903)	AUG09/11	K.L.

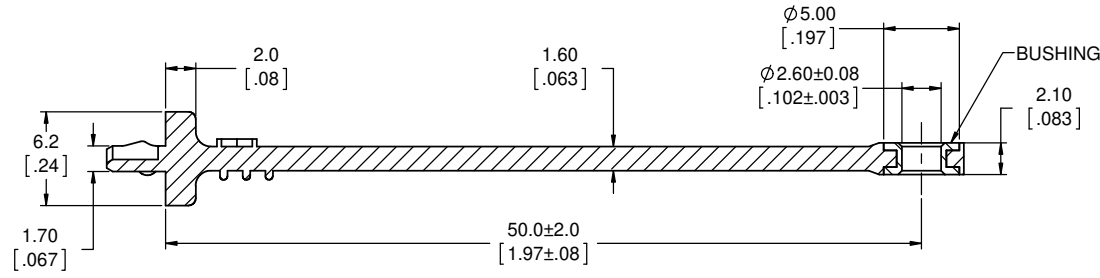

SECTION A-A  
SCALE 4 : 1

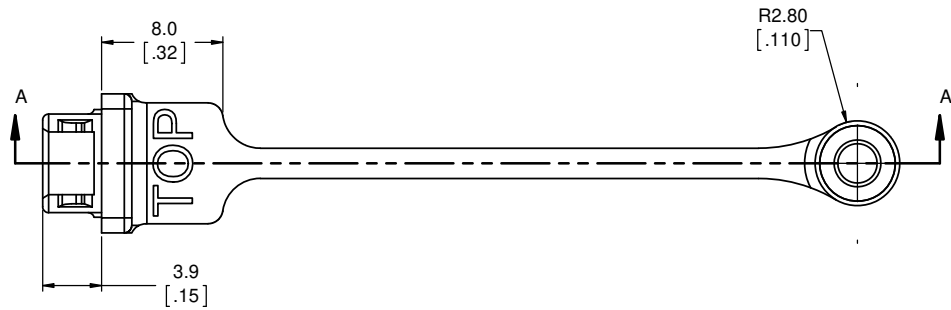
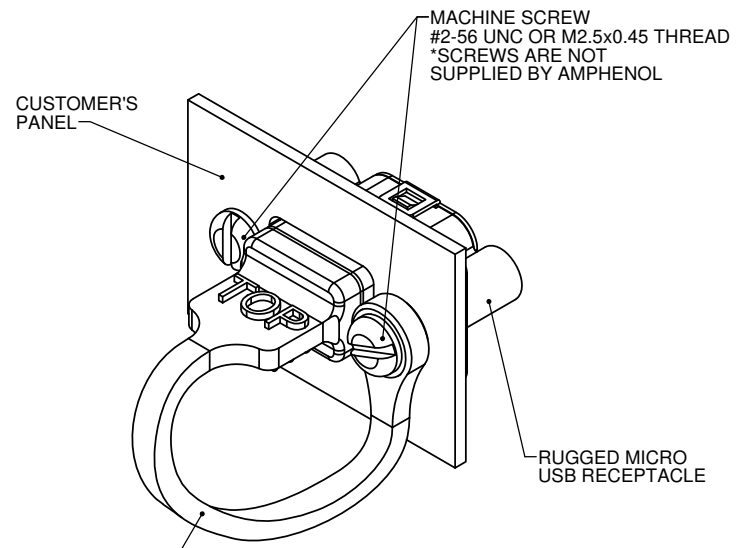
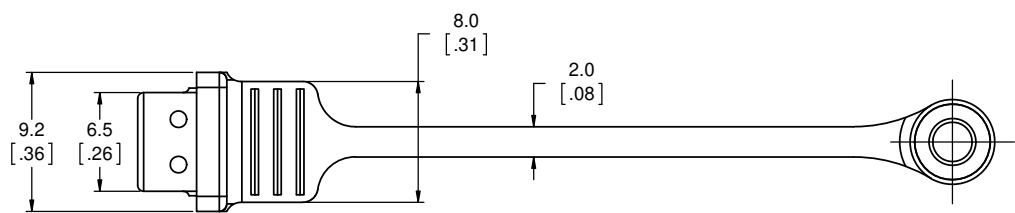

DUST COVER IN MATED CONDITION



**NOTES:**

- MATERIAL:
  - RUBBER: SILICONE RUBBER, UL94V-0, SEE CHART FOR COLOUR
  - BUSHING: BRASS ALLOY, NICKEL PLATED
- PART IS RoHS COMPLIANT PER EU DIRECTIVE 2002/95/EC AND AMENDMENTS

AMPHENOL PART NUMBER	COLOUR
MUSB-2K15-005BP	GREY
MUSB-2K15-015BP	BLACK

FEATURES DESIGNED TO CREATE AN INTERFERENCE FIT WITH RECEPTACLE

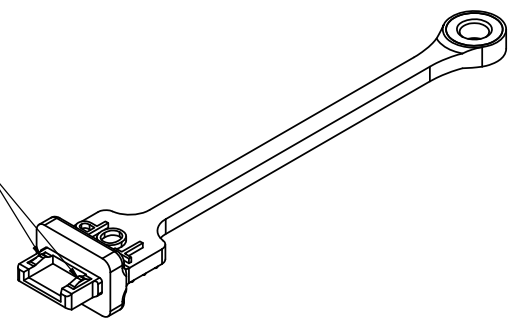

UNLESS SPECIFIED OTHERWISE	DRAWN	S.CAELERS	AUG08/11
PRIMARY UNITS MILLIMETERS	CHECKED	K.LAMBIE	AUG09/11
SECONDARY INCHES	M.E. APP'D		
REFERENCE IN PARENTHESES	Q.A. APP'D		
GENERAL TOLERANCES	DWG APPR.		
1 DECIMAL PLACE ±0.3	ENG. REL. NO.		
2 DECIMAL PLACES ±0.15	REF.		
3 DECIMAL PLACES	THIRD ANGLE PROJECTION		
ANGULAR DEGREES ±1°	DO NOT SCALE DRAWING		

<b>Amphenol Canada Corp.</b> <a href="http://www.amphenolcanada.com">www.amphenolcanada.com</a>			
<b>MUSB SERIES,          DUST COVER FOR RUGGIDIZED MICRO USB, RoHS COMPLIANT</b>			
DWG. NO.	P-MUSB-2K15-0X5BP		REV A
CODE ID NO.	03554	DWG SIZE: X	SCALE: 2:1 SHEET 1 OF 1