

EVALUATION KIT  
AVAILABLE**MAXIM**

## 5V/3.3V/3V or Adjustable, High-Efficiency, Low IQ, Step-Down DC-DC Controllers

### General Description

The MAX649/MAX651/MAX652 BiCMOS, step-down DC-DC switching controllers provide high efficiency over three decades of load current. A unique, current-limited pulse-frequency-modulated (PFM) control scheme gives these devices the benefits of pulse-width-modulation (PWM) converters (high efficiency at heavy loads), while using only 100µA of supply current (vs. 2mA to 10mA for PWM converters). The result is high efficiency over loads ranging from 10mA to more than 2.5A.

These devices use miniature external components. Their high switching frequency (up to 300kHz) allows for less than 9mm diameter surface-mount inductors.

The MAX649/MAX651/MAX652 have dropout voltages less than 1V and accept input voltages up to 16.5V. Output voltages are preset at 5V (MAX649), 3.3V (MAX651), and 3V (MAX652). These controllers can also be adjusted to any voltage from 1.5V to the input voltage by using two resistors.

These step-down controllers drive external P-channel MOSFETs at loads greater than 10W. If less power is required, use the MAX639/MAX640/MAX653 step-down converters with on-chip FETs, which allow up to a 225mA load current.

### Applications

5V-to-3.3V Green PC Applications  
High-Efficiency Step-Down Regulation  
Minimum-Component DC-DC Converters  
Battery-Powered Applications

### Typical Operating Circuit

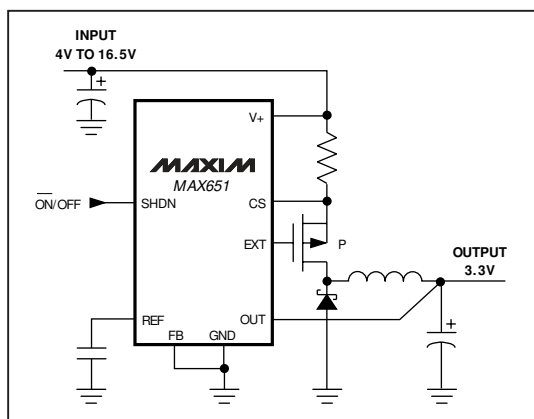

### Features

- ◆ More than 90% Efficiency (10mA to 1.5A Loads)
- ◆ More than 12.5W Output Power
- ◆ 100µA Max Quiescent Supply Current
- ◆ 5µA Max Shutdown Supply Current
- ◆ Less than 1.0V Dropout Voltage
- ◆ 16.5V Max Input Voltage
- ◆ 5V (MAX649), 3.3V (MAX651), 3V (MAX652), or Adjustable Output Voltage
- ◆ Current-Limited Control Scheme
- ◆ Up to 300kHz Switching Frequency

### Ordering Information

PART	TEMP. RANGE	PIN-PACKAGE
MAX649CPA	0°C to +70°C	8 Plastic DIP
MAX649CSA	0°C to +70°C	8 SO
MAX649C/D	0°C to +70°C	Dice*
MAX649EPA	-40°C to +85°C	8 Plastic DIP
MAX649ESA	-40°C to +85°C	8 SO
MAX649MJA	-55°C to +125°C	8 CERDIP**

Ordering Information continued at end of data sheet.

\* Dice are tested at  $T_A = +25^\circ\text{C}$ .

\*\*Contact factory for availability and processing to MIL-STD-883.

### Pin Configuration

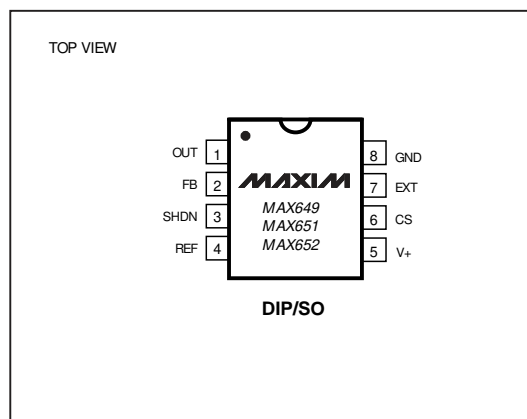

MAX649/MAX651/MAX652

**MAXIM**

Maxim Integrated Products 1

For free samples & the latest literature: <http://www.maxim-ic.com>, or phone 1-800-998-8800.  
For small orders, phone 1-800-835-8769.

# 5V/3.3V/3V or Adjustable, High-Efficiency, Low IQ, Step-Down DC-DC Controllers

## ABSOLUTE MAXIMUM RATINGS

Supply Voltage, V+ to GND.....-0.3V, +17V	Operating Temperature Ranges
REF, SHDN, FB, CS, EXT, OUT.....-0.3V, (V+ + 0.3V)	MAX649C_A, MAX65_C_A .....0°C to +70°C
Continuous Power Dissipation (TA = +70°C)	MAX649E_A, MAX65_E_A .....-40°C to +85°C
Plastic DIP (derate 9.09mW/°C above +70°C) .....727mW	MAX649MJA, MAX65_MJA .....-55°C to +125°C
SO (derate 5.88mW/°C above +70°C).....471mW	Storage Temperature Range .....-65°C to +160°C
CERDIP (derate 8.00mW/°C above +70°C) .....640mW	Lead Temperature (soldering, 10sec) .....+300°C

Stresses beyond those listed under "Absolute Maximum Ratings" may cause permanent damage to the device. These are stress ratings only, and functional operation of the device at these or any other conditions beyond those indicated in the operational sections of the specifications is not implied. Exposure to absolute maximum rating conditions for extended periods may affect device reliability.

## ELECTRICAL CHARACTERISTICS

(V+ = 5V, TA = TMIN to TMAX, unless otherwise noted. Typical values are at TA = +25°C.)

PARAMETER	SYMBOL	CONDITIONS	MIN	TYP	MAX	UNITS
V+ Input Voltage Range	V+		4.0		16.5	V
Supply Current	IQ	V+ = 16.5V, SHDN ≤ 0.4V (operating, switch off)		80	100	μA
		V+ = 16.5V, SHDN ≥ 1.6V (shutdown)		4		
		V+ = 10V, SHDN ≥ 1.6V (shutdown)		2	5	
FB Trip Point		MAX649C, MAX65_C	1.470	1.5	1.530	V
		MAX649E, MAX65_E	1.4625	1.5	1.5375	
		MAX649M, MAX65_M	1.455	1.5	1.545	
FB Input Current	IFB	MAX649C, MAX65_C			±50	nA
		MAX649E, MAX65_E			±70	
		MAX649M, MAX65_M			±90	
Output Voltage	VOUT	Circuit of Figure 1				V
		MAX649, V+ = 6V to 16.5V	4.80	5.0	5.20	
		MAX651, V+ = 4V to 16.5V	3.17	3.3	3.43	
		MAX652, V+ = 4V to 16.5V	2.88	3.0	3.12	
Reference Voltage	VREF	MAX649C, MAX65_C, IREF = 0	1.470	1.5	1.530	V
		MAX649E, MAX65_E, IREF = 0	1.4625	1.5	1.5375	
		MAX649M, MAX65_M, IREF = 0	1.455	1.5	1.545	
REF Load Regulation		0 ≤ IREF ≤ 100μA, sourcing only		4	10	mV
				4	15	
REF Line Regulation		4V ≤ V+ ≤ 16.5V		40	100	μV/V
Output Voltage Line Regulation	Circuit of Figure 1	MAX649, 6V ≤ V+ ≤ 16V, ILOAD = 1A		2.6		mV/V
		MAX651, 4.5V ≤ V+ ≤ 16V, ILOAD = 1A		1.7		
		MAX652, 4V ≤ V+ ≤ 16V, ILOAD = 1A		1.9		

## 5V/3.3V/3V or Adjustable, High-Efficiency, Low IQ, Step-Down DC-DC Controllers

### ELECTRICAL CHARACTERISTICS (continued)

(V<sub>+</sub> = 5V, T<sub>A</sub> = T<sub>MIN</sub> to T<sub>MAX</sub>, unless otherwise noted. Typical values are at T<sub>A</sub> = +25°C.)

PARAMETER	SYMBOL	CONDITIONS		MIN	TYP	MAX	UNITS
Output Voltage Load Regulation		Circuit of Figure 1	MAX649, 0 ≤ I <sub>LOAD</sub> ≤ 1.5A, V <sub>IN</sub> = 10V		-47		mV/A
			MAX651, 0 ≤ I <sub>LOAD</sub> ≤ 1.5A, V <sub>IN</sub> = 5V		-45		
			MAX652, 0 ≤ I <sub>LOAD</sub> ≤ 1.5A, V <sub>IN</sub> = 5V		-45		
Efficiency		Circuit of Figure 1	MAX649, V <sub>+</sub> = 10V, I <sub>LOAD</sub> = 1A		92		%
			MAX651, V <sub>+</sub> = 5V, I <sub>LOAD</sub> = 1A		89		
			MAX652, V <sub>+</sub> = 5V, I <sub>LOAD</sub> = 1A		88		
SHDN Input Current		V <sub>+</sub> = 16.5V, SHDN = 0V or V <sub>+</sub>				1	μA
SHDN Input Voltage High	V <sub>IH</sub>	4V ≤ V <sub>+</sub> ≤ 16.5V		1.6			V
SHDN Input Voltage Low	V <sub>IL</sub>	4V ≤ V <sub>+</sub> ≤ 16.5V				0.4	V
Current-Limit Trip Level (V <sub>+</sub> to CS)	V <sub>CS</sub>	4V ≤ V <sub>+</sub> ≤ 16.5V	MAX649C/E, MAX65_C/E	180	210	240	mV
			MAX649M, MAX65_M	160	210	260	
CS Input Current		4V ≤ V <sub>+</sub> ≤ 16.5V				±1	μA
Switch Maximum On-Time	t <sub>ON</sub> (max)	V <sub>+</sub> = 12V		12	16	20	μs
Switch Minimum Off-Time	t <sub>OFF</sub> (min)	V <sub>+</sub> = 12V		1.8	2.3	2.8	μs
EXT Rise Time		C <sub>EXT</sub> = 0.001μF, V <sub>+</sub> = 12V			50		ns
EXT Fall Time		C <sub>EXT</sub> = 0.001μF, V <sub>+</sub> = 12V			50		ns

MAX649/MAX651/MAX652

# 5V/3.3V/3V or Adjustable, High-Efficiency, Low IQ, Step-Down DC-DC Controllers

## Typical Operating Characteristics

(T<sub>A</sub> = +25°C, unless otherwise noted.)

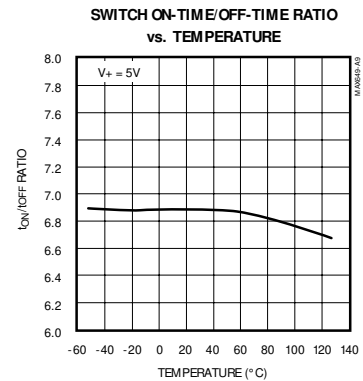
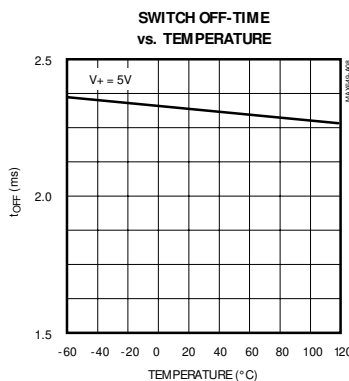
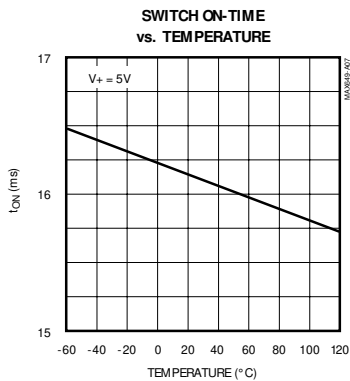
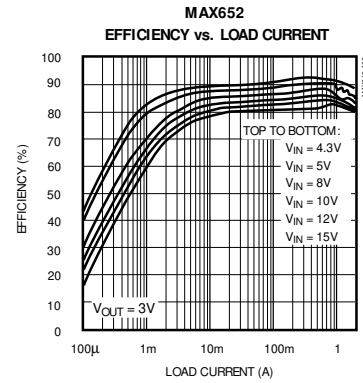
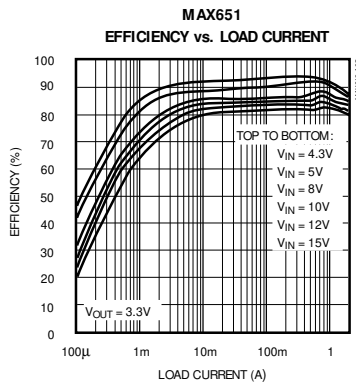
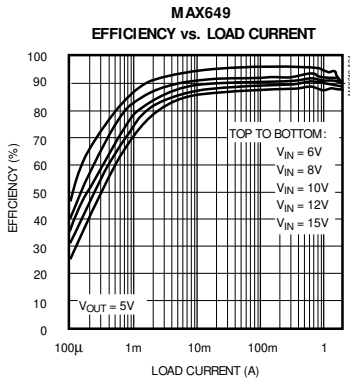
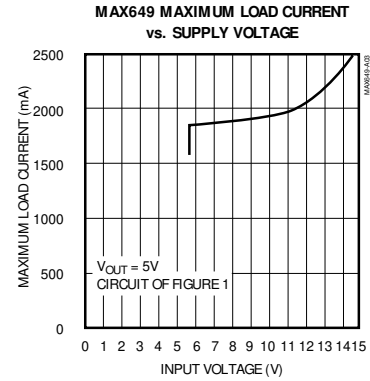
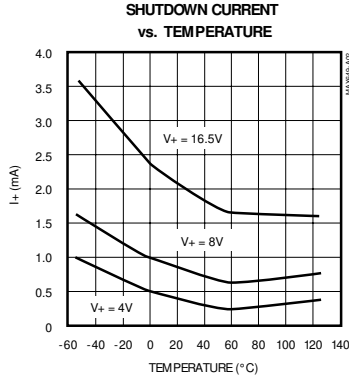
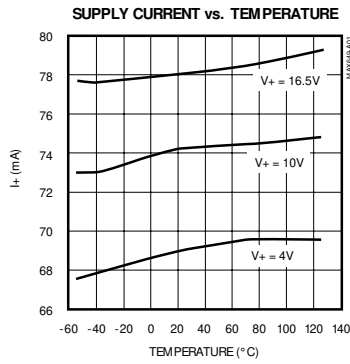

# 5V/3.3V/3V or Adjustable, High-Efficiency, Low IQ, Step-Down DC-DC Controllers

## Typical Operating Characteristics (continued)

( $T_A = +25^\circ\text{C}$ , unless otherwise noted.)

MAX649/MAX651/MAX652

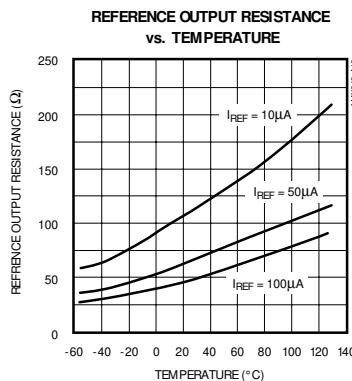
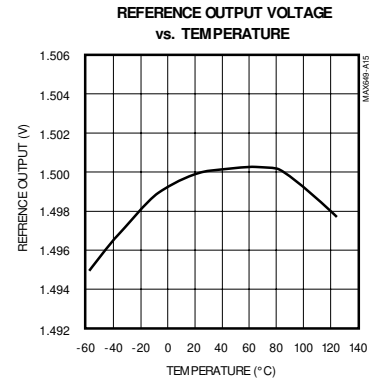
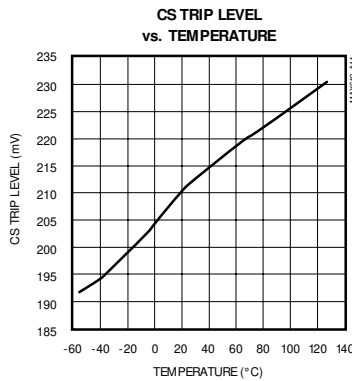
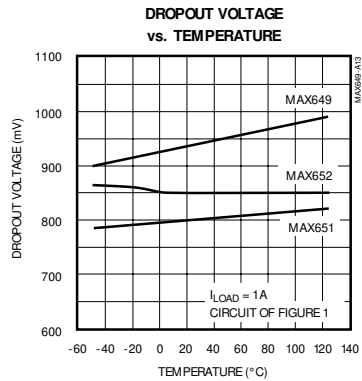
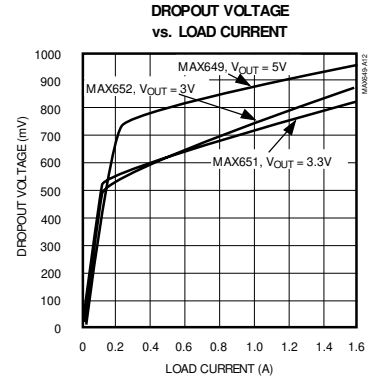
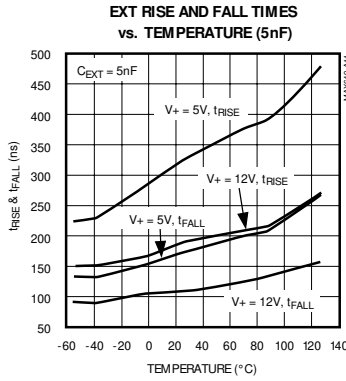
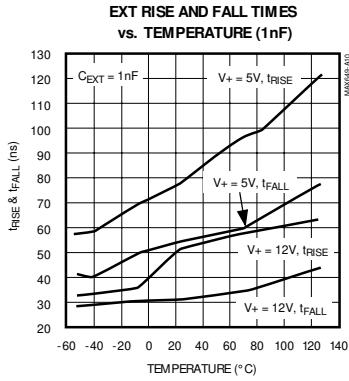

# 5V/3.3V/3V or Adjustable, High-Efficiency, Low IQ, Step-Down DC-DC Controllers

## Typical Operating Characteristics (continued)

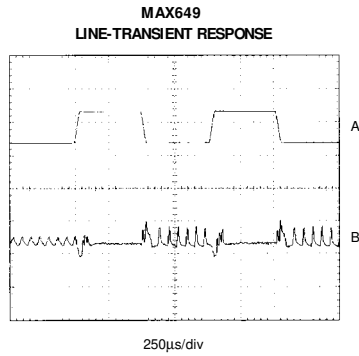

$I_{LOAD} = 1A$   
A: INPUT VOLTAGE (7V & 12V), 5V/div  
B: 5V OUT, AC COUPLED, 100mV/div

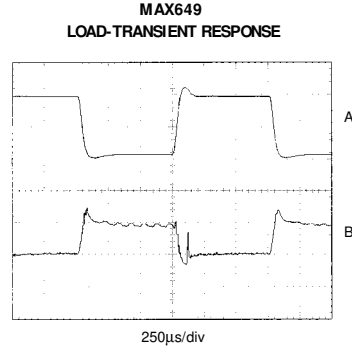

A: LOAD CURRENT (100mA & 1A), 500mA/div  
B: 5V OUTPUT VOLTAGE, AC COUPLED, 50mV/div

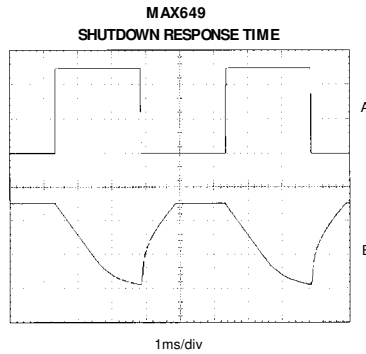

$I_{LOAD} = 1A$   
A: SHDN INPUT VOLTAGE (0V & 5V), 2V/div  
B: 5V OUTPUT VOLTAGE, 2V/div

## Pin Description

PIN	NAME	FUNCTION
1	OUT	Sense input for fixed 5V, 3.3V, or 3V output operation. OUT is internally connected to the on-chip voltage divider. Although it is connected to the output of the circuit, the OUT pin does not supply current.
2	FB	Feedback input. Connect to GND for fixed-output operation. Connect a resistor divider between OUT, FB, and GND for adjustable-output operation. See <i>Setting the Output Voltage</i> section.
3	SHDN	Active-high TTL/CMOS logic-level input. Part is placed in shutdown when SHDN is driven high. In shutdown mode, the reference and the external MOSFET are turned off, and OUT = 0V. Connect to GND for normal operation.
4	REF	1.5V reference output that can source 100µA. Bypass with 0.1µF.
5	V+	Positive power-supply input
6	CS	Current-sense input. Connect current-sense resistor between V+ and CS. When the voltage across the resistor equals the current-limit trip level, the external MOSFET is turned off.
7	EXT	Gate drive for external P-channel MOSFET. EXT swings between V+ and GND.
8	GND	Ground

## 5V/3.3V/3V or Adjustable, High-Efficiency, Low IQ, Step-Down DC-DC Controllers

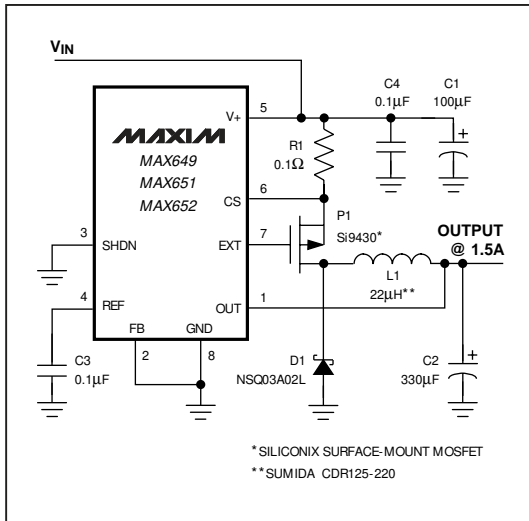

Figure 1. Test Circuit

### Detailed Description

The MAX649/MAX651/MAX652 are BiCMOS, step-down, switch-mode power-supply controllers that provide fixed outputs of 5V, 3.3V, and 3V, respectively. Their unique control scheme combines the advantages of pulse-frequency-modulation (low supply current) and pulse-width-modulation (high efficiency at high loads). An external P-channel power MOSFET allows peak currents in excess of 3A, increasing the output current capability over previous PFM devices. Figure 2 is the block diagram.

The MAX649/MAX651/MAX652 offer three main improvements over prior solutions:

- 1) The converters operate with tiny (less than 9mm diameter) surface-mount inductors, due to their 300kHz switching frequency.
- 2) The current-limited PFM control scheme allows greater than 90% efficiencies over a wide range of load currents (1.0mA to 1.5A).
- 3) The maximum supply current is only 100μA.

#### PFM Control Scheme

The MAX649/MAX651/MAX652 use a proprietary, current-limited PFM control scheme. As with traditional PFM converters, the external power MOSFET is turned on when the voltage comparator senses that the output

is out of regulation. However, unlike traditional PFM converters, switching is accomplished through the combination of a peak current limit and a pair of one-shots that set the maximum switch on-time (16μs) and minimum switch off-time (2.3μs). Once off, the minimum off-time one-shot holds the switch off for 2.3μs. After this minimum time, the switch either 1) stays off if the output is in regulation, or 2) turns on again if the output is out of regulation.

The MAX649/MAX651/MAX652 also limit the peak inductor current, which allows them to run in continuous-conduction mode and maintain high efficiency with heavy loads (Figure 3a). This current-limiting feature is a key component of the control circuitry. Once turned on, the switch stays on until either 1) the maximum on-time one-shot turns it off (16μs later), or 2) the current limit is reached.

To increase light-load efficiency, the current limit for the first two pulses is set to half the peak current limit. If those pulses bring the output voltage into regulation, the voltage comparator holds the MOSFET off and the current limit remains at half its peak. If the output voltage is still out of regulation after two pulses, the current limit for the next pulse is raised to its peak (Figure 3b). Calculate the peak current limit by dividing the Current-Limit Trip Level (see *Electrical Characteristics*) by the value of the current-sense resistor.

#### Shutdown Mode

When SHDN is high, the MAX649/MAX651/MAX652 enter shutdown mode. In this mode, the internal biasing circuitry is turned off (including the reference) and the supply current drops to less than 5μA. EXT goes high, turning off the external MOSFET. SHDN is a TTL/CMOS logic-level input. Connect SHDN to GND for normal operation.

#### Quiescent Current

In normal operation, the quiescent current is less than 100μA. However, this current is measured by forcing the external transistor switch off. In an actual application, even with no load, additional current is drawn to supply external feedback resistors (if used) and the diode and capacitor leakage currents. In the circuit of Figure 1, with V+ at 5V and VOUT at 3.3V, the typical quiescent current is 90μA.

#### EXT Drive Voltage Range

EXT swings from V+ to GND and provides the drive output for an external P-channel power MOSFET.

#### Modes of Operation

When delivering high output currents, the MAX649/MAX651/MAX652 operate in continuous-conduction mode (CCM). In this mode, current always flows in the

MAX649/MAX651/MAX652

# 5V/3.3V/3V or Adjustable, High-Efficiency, Low IQ, Step-Down DC-DC Controllers

**MAX649/MAX651/MAX652**

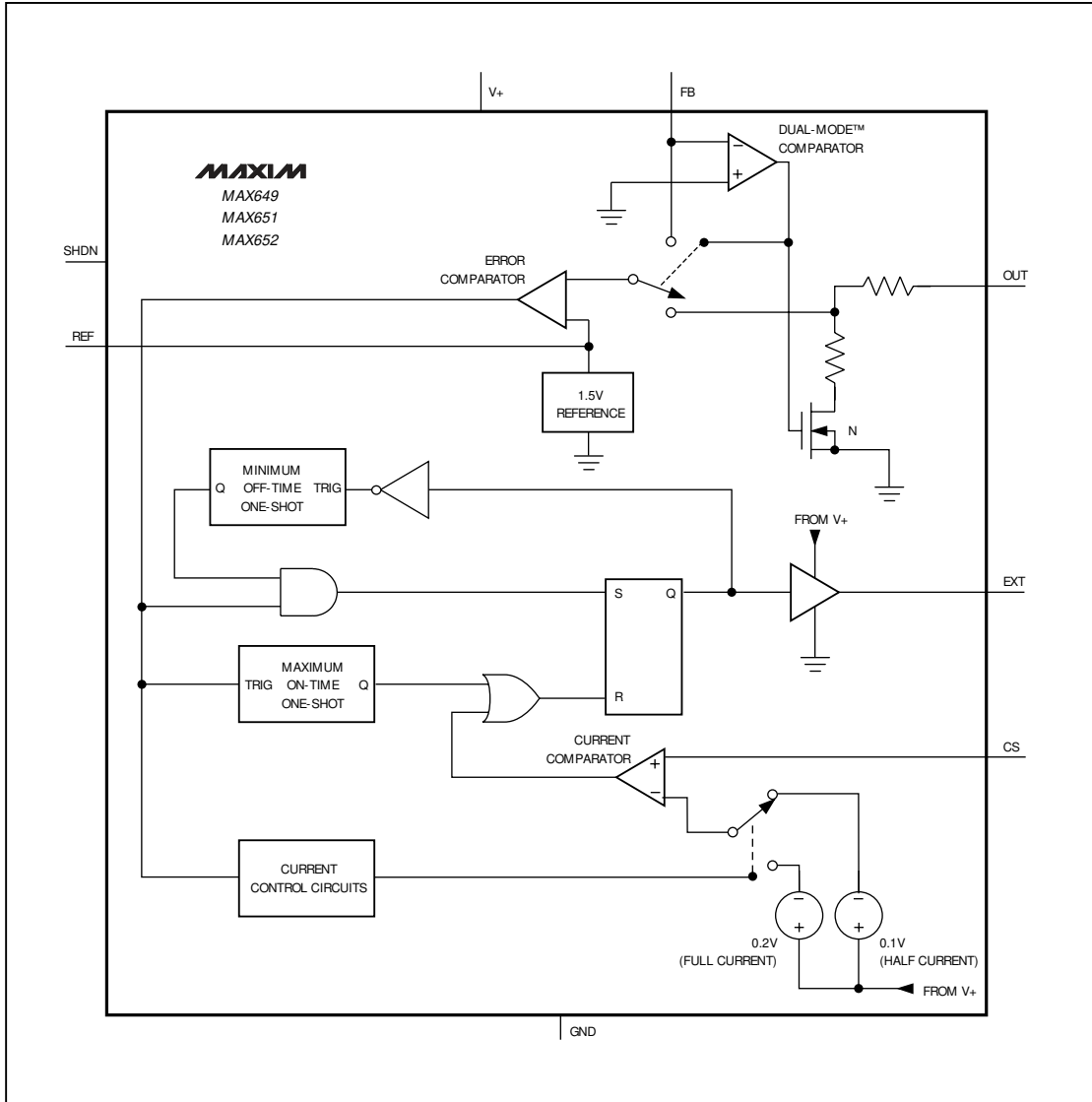

Figure 2. Block Diagram



## 5V/3.3V/3V or Adjustable, High-Efficiency, Low IQ, Step-Down DC-DC Controllers

MAX649/MAX651/MAX652

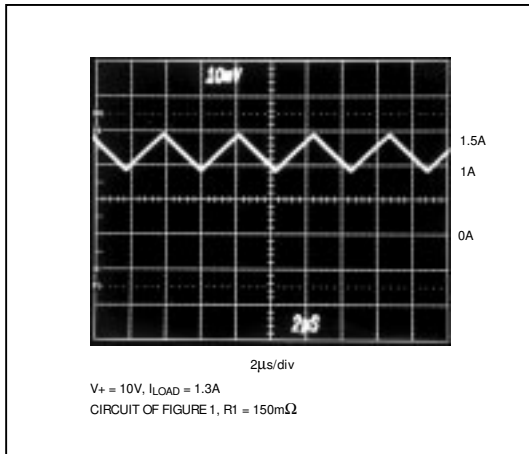

Figure 3a. MAX649 Continuous-Conduction Mode, Heavy Load-Current Waveform (500mA/div)

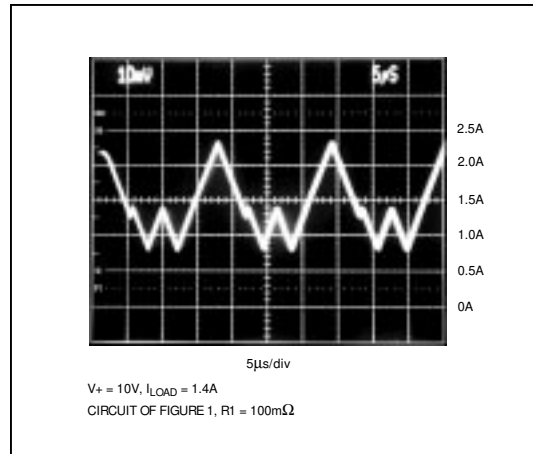

Figure 3b. MAX649 Light/Medium Load-Current Waveform (500mA/div)

inductor, and the control circuit adjusts the switch duty cycle to maintain regulation without exceeding the switch current capability (Figure 3a). This provides excellent load-transient response and high efficiency.

In discontinuous-conduction mode (DCM), current through the inductor starts at zero, rises to a peak value, then ramps down to zero. Although efficiency is still excellent, the output ripple increases slightly, and the switch waveforms exhibit ringing (the self-resonant frequency of the inductor). This ringing is to be expected and poses no operational problems.

### Dropout

The MAX649/MAX651/MAX652 are said to be in dropout when the input voltage ( $V_+$ ) is low enough that the output drops below the minimum output voltage specification (see *Electrical Characteristics*). The dropout voltage is the difference between the input and output when dropout occurs. See the *Typical Operating Characteristics* for the Dropout Voltage vs. Load Current and Dropout Voltage vs. Temperature graphs.

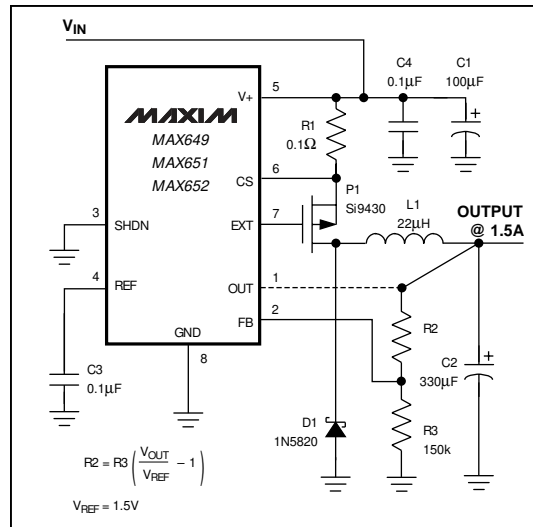

Figure 4. Adjustable-Output Operation

## 5V/3.3V/3V or Adjustable, High-Efficiency, Low IQ, Step-Down DC-DC Controllers

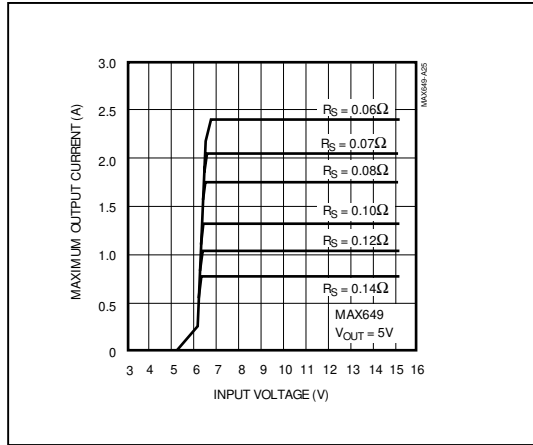

Figure 5a. MAX649 Current-Sense Resistor Graph

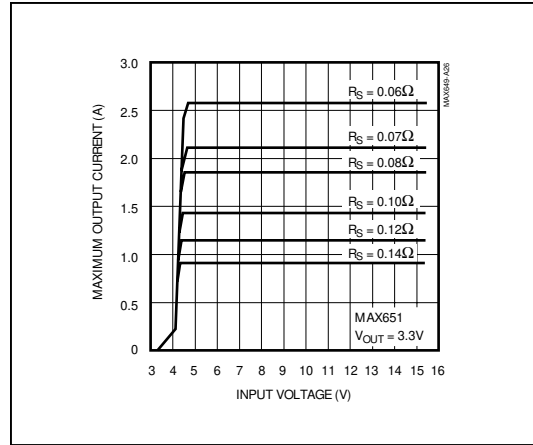

Figure 5b. MAX651 Current-Sense Resistor Graph

### Design Procedure

#### Setting the Output Voltage

The MAX649/MAX651/MAX652 are preset for 5V, 3.3V, and 3V output voltages, respectively. Tie FB to GND for fixed-output operation. They may also be adjusted from 1.5V (the reference voltage) to the input voltage, using external resistors R2 and R3 configured as shown in Figure 4. For adjustable-output operation, 150kΩ is recommended for resistor R3. 150kΩ is a good value—high enough to avoid wasting energy, yet low enough to avoid RC delays caused by parasitic capacitance at FB. R2 is given by:

$$R2 = R3 \times \left[ \frac{V_{OUT}}{V_{REF}} - 1 \right]$$

where  $V_{REF} = 1.5V$ .

When using external resistors, it does no harm to connect OUT and the output together, or to leave OUT unconnected.

#### Current-Sense Resistor Selection

The current-sense resistor limits the peak switch current to  $210mV/R_{SENSE}$ , where  $R_{SENSE}$  is the value of the current-sense resistor, and 210mV is the current-limit trip level (see *Electrical Characteristics*).

To maximize efficiency and reduce the size and cost of external components, minimize the peak current. However, since the available output current is a function of the peak current, the peak current must not be too low.

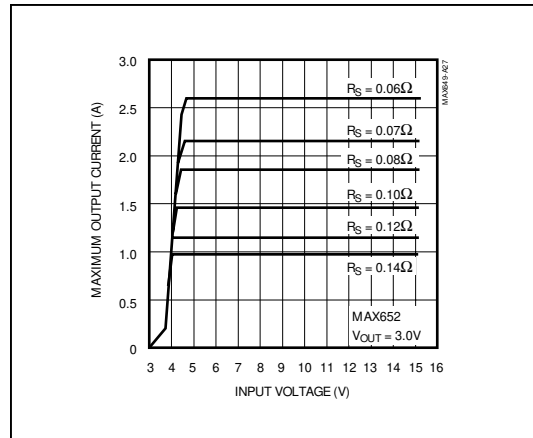

Figure 5c. MAX652 Current-Sense Resistor Graph

To choose the proper current-sense resistor for a particular output voltage, determine the minimum input voltage and the maximum load current. Next, referring to Figures 5a, 5b, or 5c, using the minimum input voltage, find the curve with the largest sense resistor that provides sufficient output current. It is not necessary to perform worst-case calculations. These curves take into account the worst-case values for sense resistor ( $\pm 5\%$ ), inductor ( $22\mu H \pm 10\%$ ), diode drop (0.6V), and the IC's current-sense trip level; an external MOSFET on-resistance of  $0.13\Omega$  is assumed for  $V_{GS} = -4.5V$ .

## 5V/3.3V/3V or Adjustable, High-Efficiency, Low IQ, Step-Down DC-DC Controllers

Standard wire-wound and metal-film resistors have an inductance high enough to degrade performance. Surface-mount (chip) resistors have very little inductance and are well suited for use as current-sense resistors. A wire resistor made by IRC works well in through-hole applications. Because this resistor is a band of metal shaped as a "U", its inductance is less than 10nH (an order of magnitude less than metal film resistors). Resistance values between 5mΩ and 0.1Ω are available (see Table 1).

### Inductor Selection

Practical inductor values range from 10μH to 50μH or more. The circuit operates in discontinuous-conduction mode if:

$$V_+ \leq \frac{V_{OUT} \times (R + 1)}{R} + \frac{V_D}{R} + V_{SW}$$

R, the switch on-time/off-time ratio, equals 6.7.  $V_D$  is the diode's drop, and  $V_{SW}$  is the voltage drop across the P-channel FET. To get the full output capability in discontinuous-conduction mode, choose an inductor value no larger than:

$$L(\max) = \frac{R_{SENSE} \times 12\mu\text{s} \times (V_+ - V_{SW} - V_{OUT})}{V_{CS}}$$

where  $V_{CS}$  is the current-sense voltage.

In both the continuous and discontinuous modes, the lower limit of the inductor is more important. With a small inductor value, the current rises faster and overshoots the desired peak current limit because the current-limit comparator cannot respond fast enough. This reduces efficiency slightly and, more importantly, could cause the current rating of the external components to be exceeded. Calculate the minimum inductor value as follows:

$$L(\min) = \frac{(V_+(\max) - V_{SW} - V_{OUT}) \times 0.3\mu\text{s}}{\Delta \times I_{LIM}(\min)}$$

where  $\Delta$  is the percentage of inductor-current overshoot, where  $I_{LIM} = V_{CS}/R_{SENSE}$  and 0.3μs is the time it takes the comparator to switch. An overshoot of 10% is usually not a problem. Inductance values above the minimum work well if the maximum value defined above is not exceeded. Smaller inductance values cause higher output ripple because of overshoot. Larger values tend to produce physically larger coils.

For highest efficiency, use a coil with low DC resistance; a value smaller than 0.1V/ $I_{LIM}$  works best. To minimize radiated noise, use a toroid, pot core, or shielded-bobbin inductor. Inductors with a ferrite core or equivalent are recommended. Make sure the induc-

tor's saturation-current rating is greater than  $I_{LIM}(\max)$ . However, it is generally acceptable to bias the inductor into saturation by about 20% (the point where the inductance is 20% below its nominal value).

The peak current of Figure 1 is 2.35A for a 1.5A output. The inductor used in this circuit is specified to drop by 10% at 2.2A (worst case); a curve provided by the manufacturer shows that the inductance typically drops by 20% at 3.1A. Using a slightly underrated inductor can sometimes reduce size and cost, with only a minor impact on efficiency. The MAX649/MAX651/MAX652 current limit prevents any damage from an underrated inductor's low inductance at high currents.

Table 1 lists inductor types and suppliers for various applications. The efficiencies of the listed surface-mount inductors are nearly equivalent to those of the larger size through-hole versions.

### Diode Selection

The MAX649/MAX651/MAX652's high switching frequency demands a high-speed rectifier (commonly called a catch diode when used in switching-regulator circuits). Schottky diodes, such as the 1N5817 through 1N5822 families (and their surface-mount equivalents), are recommended. Choose a diode with an average current rating equal to or greater than  $I_{LIM}(\max)$  and a voltage rating higher than  $V_+(\max)$ . For high-temperature applications, where Schottky diodes can be inadequate because of high leakage currents, use high-speed silicon diodes instead. At heavy loads and high temperatures, the disadvantages of a Schottky diode's high leakage current may outweigh the benefits of its low forward voltage. Table 1 lists diode types and suppliers for various applications.

### External Switching Transistor

The MAX649/MAX651/MAX652 drive P-channel enhancement-mode MOSFET transistors only. The choice of power transistor is primarily dictated by the input voltage and the peak current. The transistor's on-resistance, gate-source threshold, and gate capacitance must also be appropriately chosen. The drain-to-source and gate-to-source breakdown voltage ratings must be greater than  $V_+$ . The total gate-charge specification is normally not critical, but values should be less than 100nC for best efficiency. The MOSFET should be capable of handling the peak current and, for maximum efficiency, have a very low on-resistance at that current. Also, the on-resistance must be low for the minimum available  $V_{GS}$ , which equals  $V_+(\min)$ . Select a transistor with an on-resistance between 50% and 100% of the current-sense resistor. The Si9430 transistor chosen for the *Typical Operating Circuit* has

## 5V/3.3V/3V or Adjustable, High-Efficiency, Low IQ, Step-Down DC-DC Controllers

a drain-to-source rating of -20V and a typical on-resistance of  $0.115\Omega$  at 2A with  $V_{GS} = -4.5V$ . Tables 1 and 2 list suppliers of switching transistors suitable for use with these devices.

### Capacitor Selection

#### Output Filter Capacitor

The primary criterion for selecting the output filter capacitor is low equivalent series resistance (ESR), rather than high capacitance. An electrolytic capacitor with low enough ESR will automatically have high enough capacitance. The product of the inductor-current variation and the ESR of the output filter capacitor determines the amplitude of the high-frequency ripple seen on the output voltage. When a  $330\mu F$ , 10V Sprague surface-mount capacitor (595D series) with  $ESR = 0.15\Omega s$  is used, 40mV of output ripple is typically observed when stepping down from 10V to 5V at 1A.

The output filter capacitor's ESR also affects efficiency. Use low-ESR capacitors for best performance. The smallest low-ESR SMT tantalum capacitors currently available are from the Sprague 595D series. Sanyo OS-CON organic semiconductor through-hole capacitors and the Nichicon PL series also exhibit very low ESR. Table 1 lists some suppliers of low-ESR capacitors.

#### Input Bypass Capacitor

The input bypass capacitor reduces peak currents drawn from the voltage source, and also reduces the

amount of noise at the voltage source caused by the switching action of the MAX649/MAX651/MAX652. The input voltage source impedance determines the size of the capacitor required at the  $V+$  input. As with the output filter capacitor, a low-ESR capacitor is recommended. Bypass the IC separately with a  $0.1\mu F$  ceramic capacitor placed close to the  $V+$  and GND pins.

#### Reference Capacitor

Bypass REF with a  $0.1\mu F$  or larger capacitor. REF can source at least  $100\mu A$ .

#### Layout Considerations

Proper PC board layout is essential because of high current levels and fast switching waveforms that radiate noise. Minimize ground noise by connecting the anode of the catch diode, the input bypass capacitor ground lead, and the output filter capacitor ground lead to a single point ("star" ground configuration). A ground plane is recommended. Also minimize lead lengths to reduce stray capacitance, trace resistance, and radiated noise. In particular, the traces connected to FB (if an external resistor divider is used) and EXT must be short. Place the  $0.1\mu F$  ceramic bypass capacitor as close as possible to  $V+$  and GND.

Table 1. Component Selection Guide

PRODUCTION METHOD	INDUCTORS	CAPACITORS	DIODES	CURRENT-SENSE RESISTORS	MOSFETS
Surface Mount	Sumida CDR125-220 ( $22\mu H$ )  Coiltronics CTX 100 series	Matsuo 267 series  Sprague 595D series	Nihon NSQ series	IRC LRC series	Siliconix Little Foot series  Motorola medium-power surface-mount products
Miniature Through-Hole	Sumida RCH855-220M	Sanyo OS-CON series low-ESR organic semiconductor		IRC OAR series	Motorola
Low-Cost Through-Hole	Renco RL 1284-22	Nichicon PL series low-ESR electrolytics  United Chemi-Con LXF series	Motorola 1N5820, 1N5823		Motorola TMOS power MOSFETs

## 5V/3.3V/3V or Adjustable, High-Efficiency, Low IQ, Step-Down DC-DC Controllers

**MAX649/MAX651/MAX652**

**Table 2. Component Suppliers**

COMPANY		PHONE	FAX
Coiltronics	USA	(407) 241-7876	(407) 241-9339
Harris	USA	(800) 442-7747	(407) 724-3937
International Rectifier	USA	(310) 322-3331	(310) 322-3332
IRC	USA	(704) 264-8861	(704) 264-8866
Matsuo	USA	(714) 969-2491	(714) 960-6492
	Japan	81-6-337-6450	81-6-337-6456
Motorola	USA	(800) 521-6274	(602) 244-4015
Nichicon	USA	(708) 843-7500	(708) 843-2798
	Japan	81-7-5231-8461	81-7-5256-4158
Nihon	USA	(805) 867-2555	(805) 867-2556
	Japan	81-3-3494-7411	81-3-3494-7414
Renco	USA	(516) 586-5566	(516) 586-5562
Sanyo	USA	(619) 661-6835	(619) 661-1055
	Japan	81-7-2070-6306	81-7-2070-1174
Siliconix	USA	(408) 988-8000	(408) 970-3950
Sprague	USA	(603) 224-1961	(603) 224-1430
Sumida	USA	(708) 956-0666	(708) 956-0702
	Japan	81-3-3607-5111	81-3-3607-5144
United Chemi-Con	USA	(714) 255-9500	(714) 255-9400

### Ordering Information (continued)

PART	TEMP. RANGE	PIN-PACKAGE
MAX651CPA	0°C to +70°C	8 Plastic DIP
MAX651CSA	0°C to +70°C	8 SO
MAX651C/D	0°C to +70°C	Dice*
MAX651EPA	-40°C to +85°C	8 Plastic DIP
MAX651ESA	-40°C to +85°C	8 SO
MAX651MJA	-55°C to +125°C	8 CERDIP**
MAX652CPA	0°C to +70°C	8 Plastic DIP
MAX652CSA	0°C to +70°C	8 SO
MAX652C/D	0°C to +70°C	Dice*
MAX652EPA	-40°C to +85°C	8 Plastic DIP
MAX652ESA	-40°C to +85°C	8 SO
MAX652MJA	-55°C to +125°C	8 CERDIP**

\* Dice are tested at  $T_A = +25^\circ\text{C}$ .

\*\*Contact factory for availability and processing to MIL-STD-883.

### Chip Topography

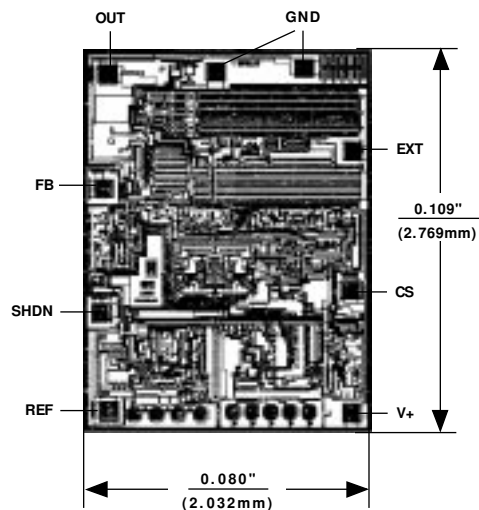

TRANSISTOR COUNT: 442;  
SUBSTRATE CONNECTED TO V+.

# 5V/3.3V/3V or Adjustable, High-Efficiency, Low IQ, Step-Down DC-DC Controllers

## Package Information

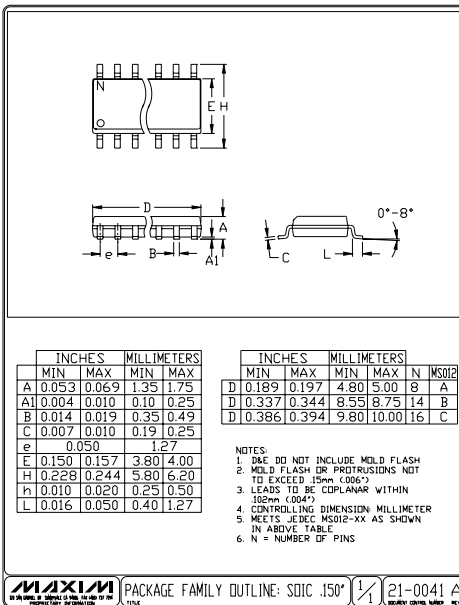
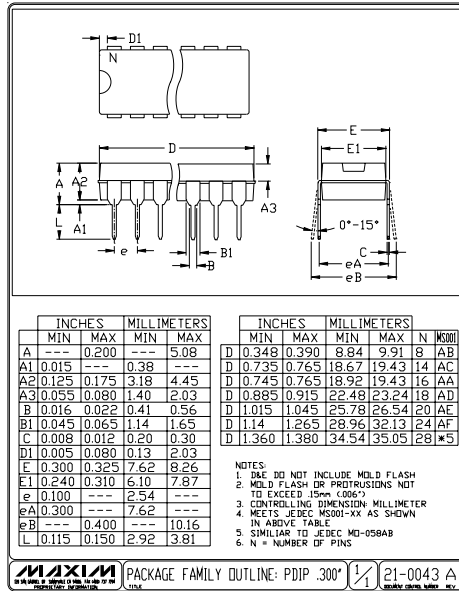

# 5V/3.3V/3V or Adjustable, High-Efficiency, Low IQ, Step-Down DC-DC Controllers

## Package Information (continued)

MAX649/MAX651/MAX652

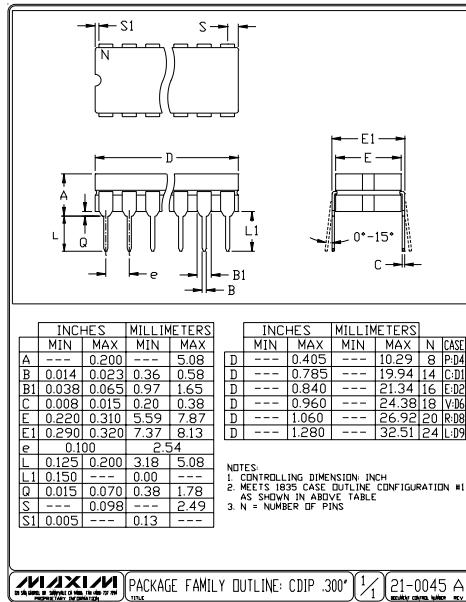

**MAX649/MAX651/MAX652**

## **5V/3.3V/3V or Adjustable, High-Efficiency, Low IQ, Step-Down DC-DC Controllers**

### NOTES

*Maxim cannot assume responsibility for use of any circuitry other than circuitry entirely embodied in a Maxim product. No circuit patent licenses are implied. Maxim reserves the right to change the circuitry and specifications without notice at any time.*

16 \_\_\_\_\_ **Maxim Integrated Products, 120 San Gabriel Drive, Sunnyvale, CA 94086 408-737-7600**

© 1997 Maxim Integrated Products

Printed USA

**MAXIM** is a registered trademark of Maxim Integrated Products.