

THIS DRAWING IS UNPUBLISHED. RELEASED FOR PUBLICATION
 © COPYRIGHT - By - ALL RIGHTS RESERVED.

LOC	DIST	REVISIONS					
CM	00	P	LTR	DESCRIPTION	DATE	DWN	APVD
		E		REVISED PER EC 0G3B-0231-05	04MAR05	KW	CJ
		E1		REVISED PER ECR-14-000999	25JUL14	GK	KD

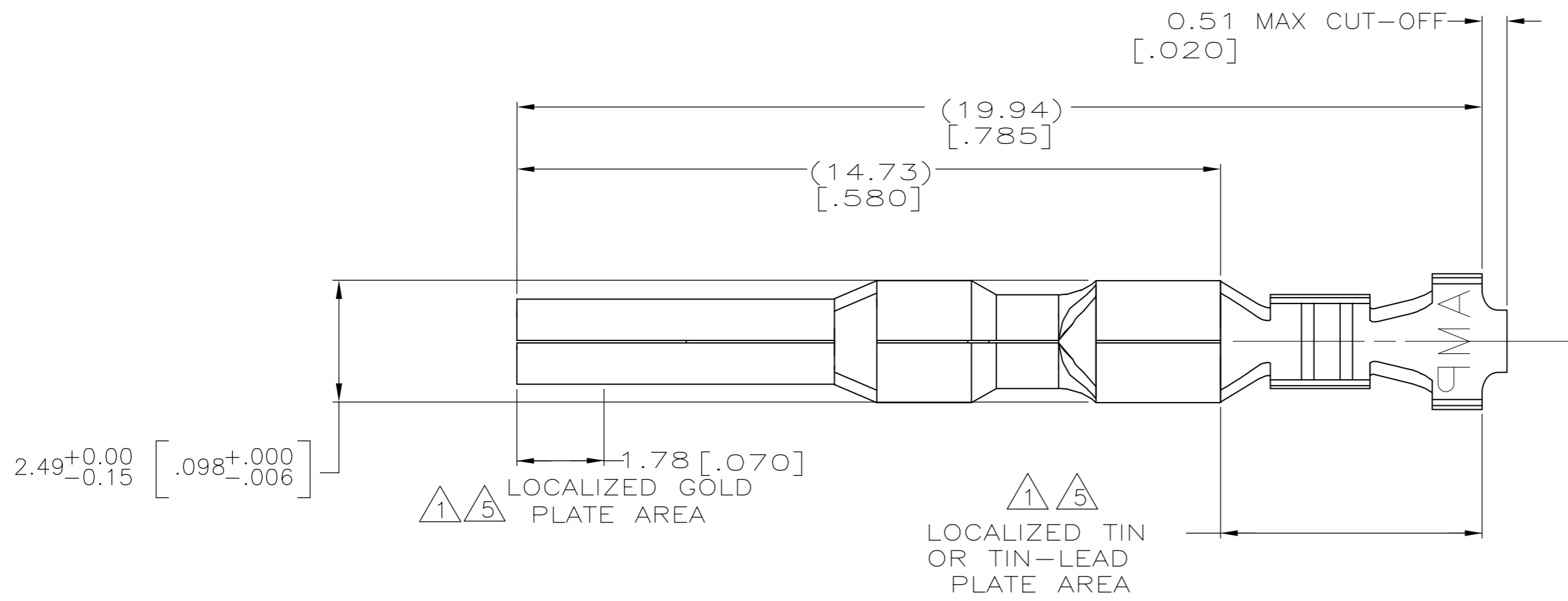

- ① 0.00076 [.000030] MIN GOLD IN LOCALIZED GOLD PLATE AREA AND 0.00254 [.000100] MIN BRIGHT TIN-LEAD IN LOCALIZED TIN-LEAD PLATE AREA OVER 0.0013 [.000050] MIN NICKEL.
- 2. WIRE RANGE: 0.12 - 0.4MM² (26-22 AWG).
- 3. INSULATION RANGE: 1.19-1.75 [.047-.069] DIA.
- 4. DIMENSIONS IN BRACKETS ARE IN INCHES.
- ⑤ 0.00076 [.000030] MIN GOLD IN LOCALIZED GOLD PLATE AREA AND 0.00254 [.000100] MIN MATTE TIN IN LOCALIZED TIN PLATE AREA OVER 0.0013 [.000050] MIN NICKEL.
- ⑥ ROHS COMPLIANT.

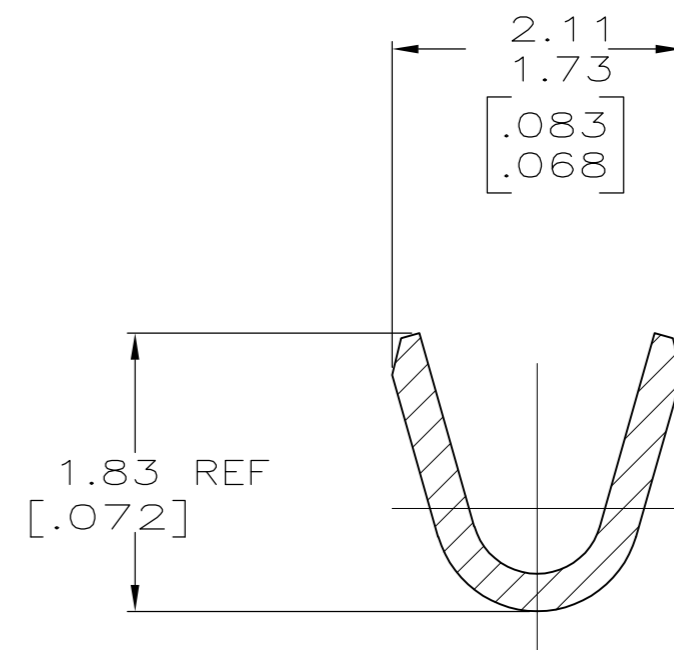
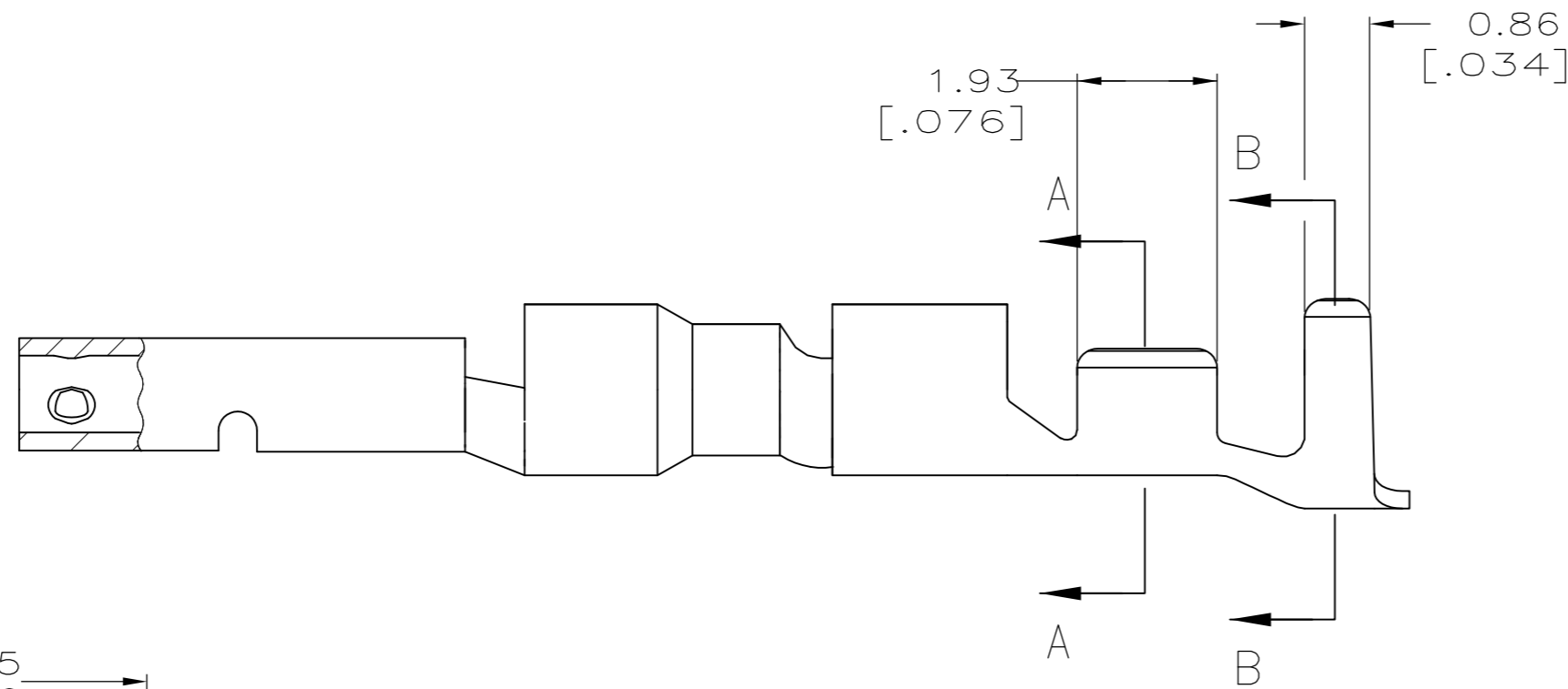

SECTION A-A
SCALE 20:1

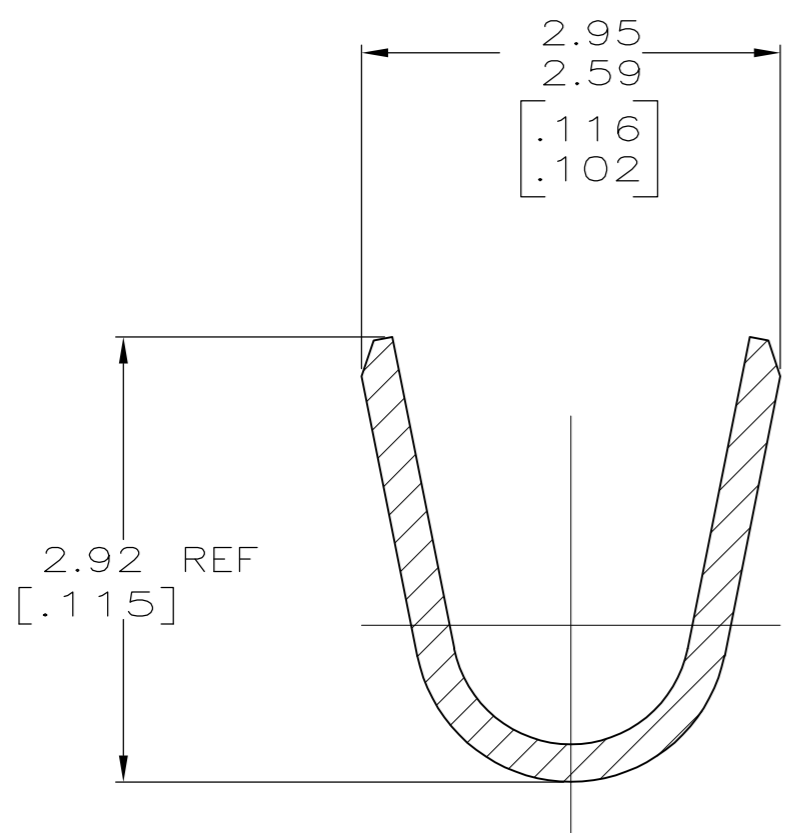

SECTION B-B
SCALE 20:1

⑥	⑤	0.25 [.010] BRASS	1-794227-0
	①	0.25 [.010] BRASS	794227-3
		PRE-TIN	0.25 [.010] BRASS
		FINISH	MATERIAL
			PART NO

THIS DRAWING IS A CONTROLLED DOCUMENT.		DWN K. WHITAKER 04MAR2005	TE Connectivity	
DIMENSIONS: mm [INCHES]		CHK C. JONES 04MAR2005	NAME SOCKET, LOOSE PIECE, MINI UNIVERSAL MATE-N-LOK(TM) 2	
TOLERANCES UNLESS OTHERWISE SPECIFIED:		APVD C. JONES 04MAR2005	SIZE A2	CAGE CODE 00779
0 PLC ± -		PRODUCT SPEC	DRAWING NO C=794227	RESTRICTED TO
1 PLC ± -		APPLICATION SPEC	SCALE 10:1	SHEET 1 of 1
2 PLC ± -		WEIGHT	REV E1	
3 PLC ± 0.30 [.012]				
4 PLC ± -				
ANGLES ± -				
MATERIAL SEE TABLE	FINISH SEE TABLE	CUSTOMER DRAWING		

