

LOC	DIST	ZONE	LTR	REVISIONS	DATE	APPD
G	14		B	REVISED PER 0720-0230-93	2/25/94	DAV

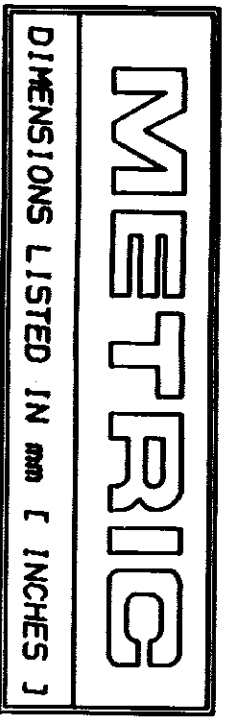

AMP WIRE RANGE 16-14 AWG STRANDED	UL E13288 Listed
AMP WIRE RANGE 16-14 AWG STRANDED	MILITARY P/N AND CLASS NOT APPLICABLE

NOT CERTIFIED	MILITARY P/N AND CLASS
CERTIFIED	NOT APPLICABLE

△ STAMP AMP 16-14* APPROX AS SHOWN

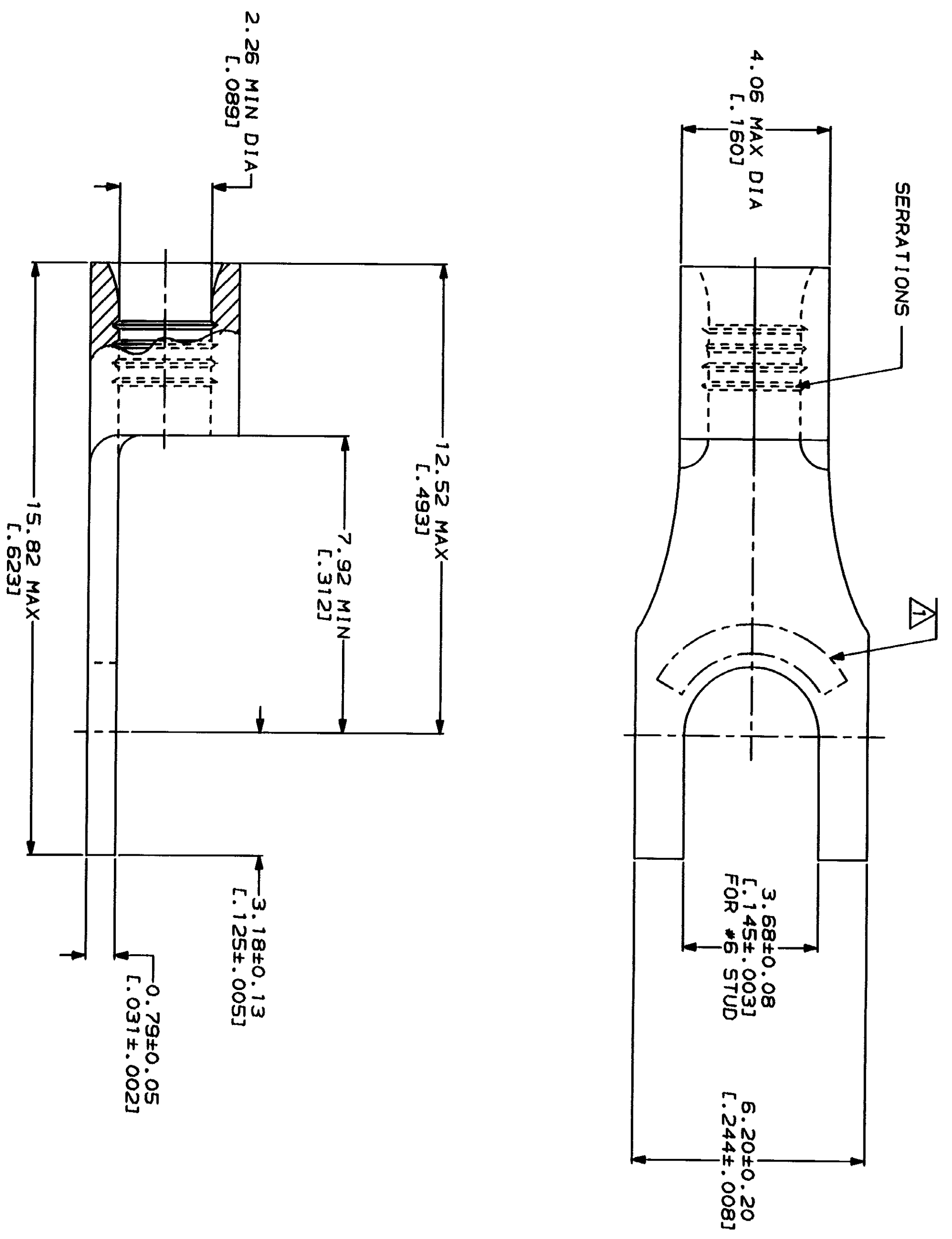

AMP INCORPORATED
CUSTOMER SERVICE SYSTEMS

FOR ADDITIONAL PRODUCT INFORMATION OR COPIES OF DRAWINGS AND TECHNICAL DOCUMENTS
1-800-522-6752
PRODUCT INFORMATION CENTER

FOR APPLICATION TOOLING INFORMATION
1-800-722-1111
TOOLING ASSISTANCE CENTER

FOR ORDER ENTRY
1-800-526-5142

MAX RECOMMENDED OPERATING TEMPERATURE:
170°C MAX

VOLTAGE RATING:
NOT APPLICABLE

WIRE CROSS SECTIONAL AREA RANGE:
1.04-2.62mm² [2,050-5,180] CIR MILS
STRANDED

DO NOT SCALE PRINT. UNLESS SPECIFIED DIMENSIONS IN - - - - - THICKNESS TOLERANCES ON - - - - - ANGLES ± - - - - -

3 PLC DEC # - - - - -
2 PLC DEC # - - - - -
1 PLC DEC # - - - - -

MATERIAL
COPPER PER ASTM B-152 ANNEALED

FINISH
TIN PLATE
0.00254 [L.000100] MIN THK PER MIL-T-10727

DR 2-17-93 TA BRINKMAN	NAME	AMP	AMP Incorporated Harrisburg, PA 17105-3508
CHK 2-17-93 DA PATTERSON	TERMINAL, SPADE TONGUE, BUDGET	33221	PART NO
APPD 2-17-93 DE MILLER	SIZE	CAGE CODE	DRAWING NO
APPD 2-17-93 JL NECKLEY	00779	00779	G-33221
PRODUCT SPEC	SCALE	10:1	SHEET
APPLICATION SPEC	1 OF 1		

CUSTOMER DRAWING