

DESCRIPTION: 25 POS MALE SURFACE MOUNT

MATERIAL/FINISH:
 SHELL: STEEL ZINC OR TIN PLATED
 BRACKET: BRASS, NICKEL PLATED
 INSULATOR: NYLON 6T - UL 94V-O, BLACK
 (TEMPERATURE RESISTANCE 250°C FOR 60 SECS.)
 Pc 99 COLORFUL INSULATOR: PATONE #322C
 CONTACT: PHOSPHOR BRONZE
 GOLD FLASH (MATING AREA) - TIN/LEAD (TERMINATING AREA)

SPECIFICATIONS:
 RATED CURRENT: 5A
 RATED VOLTAGE: 300V DC
 WITHSTANDING VOLTAGE: 500V (rms) AC FOR 1 MINUTE
 INSULATION RESISTANCE: MORE THAN 1000M ohm AT 500V DC
 CONTACT RESISTANCE: 13m ohms MAX.
 DIELECTRIC STRENGTH: 1000V AC FOR 1 MINUTE

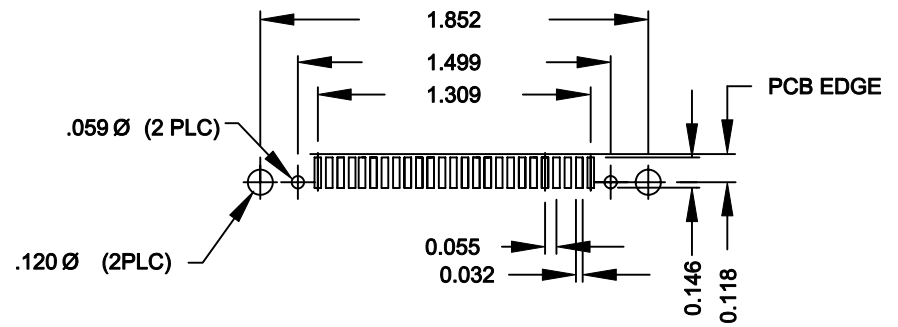
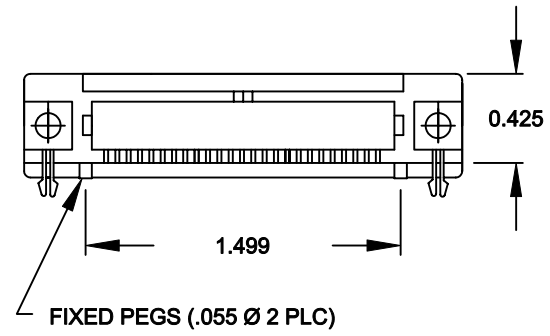
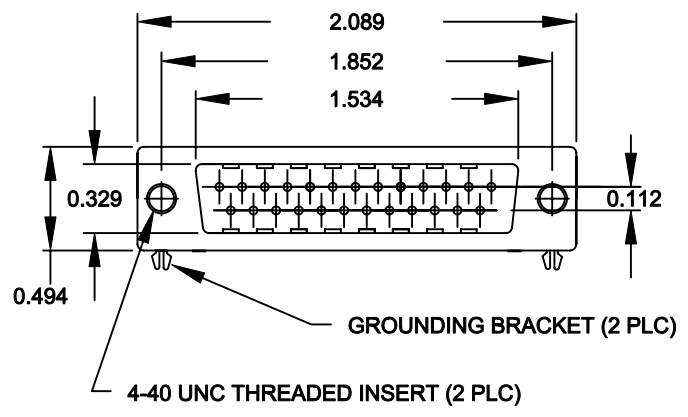
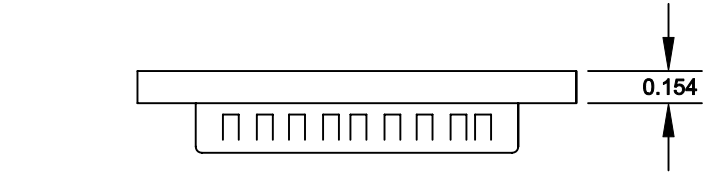

CONTACT ARRANGEMENT
 13 25 12 24 11 23 10 22 9 21 8 20 7 19 6 18 5 17 4 16 3 15 2 14 1
RECOMMENDED PCB LAYOUT

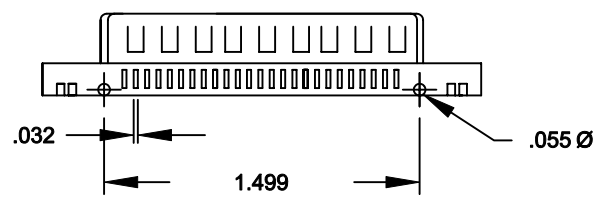

	THESE DRAWINGS AND SPECIFICATIONS ARE THE PROPERTY OF NorComp AND SHALL NOT BE REPRODUCED, COPIED OR USED AS THE BASIS FOR THE MANUFACTURE OR SALE OF APPARATUS WITHOUT WRITTEN PERMISSION.		DRAWN: PAM JENKINS	DATE: 8-21-02
			CHECKED:	DATE:
<h1>NorComp</h1>	SCALE:	SHEET 1 OF 1	REV 2	
	DWG NO. 190-025-162-001			