

LOC		DIST		REVISIONS			
P	LTR	DESCRIPTION	DATE	DWN	APPD		
A		REV PER EC 0512-0573-04	05-05-05	JA	SF		

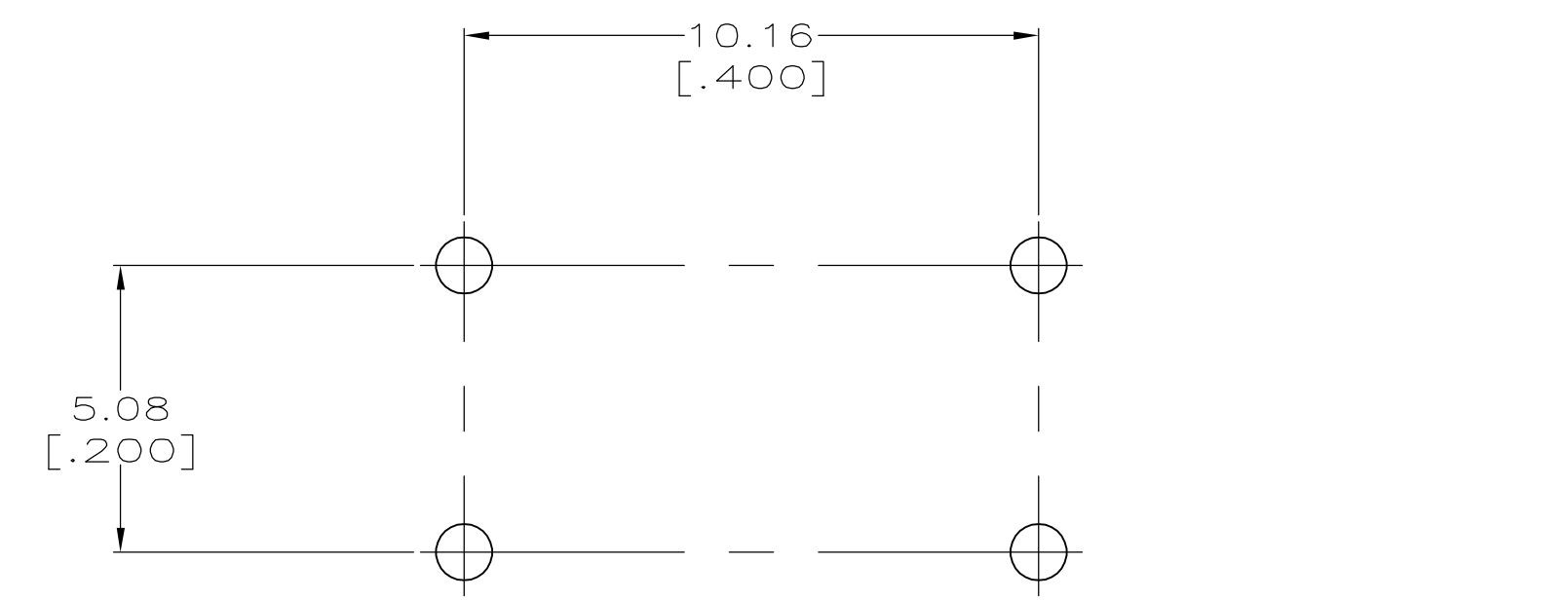
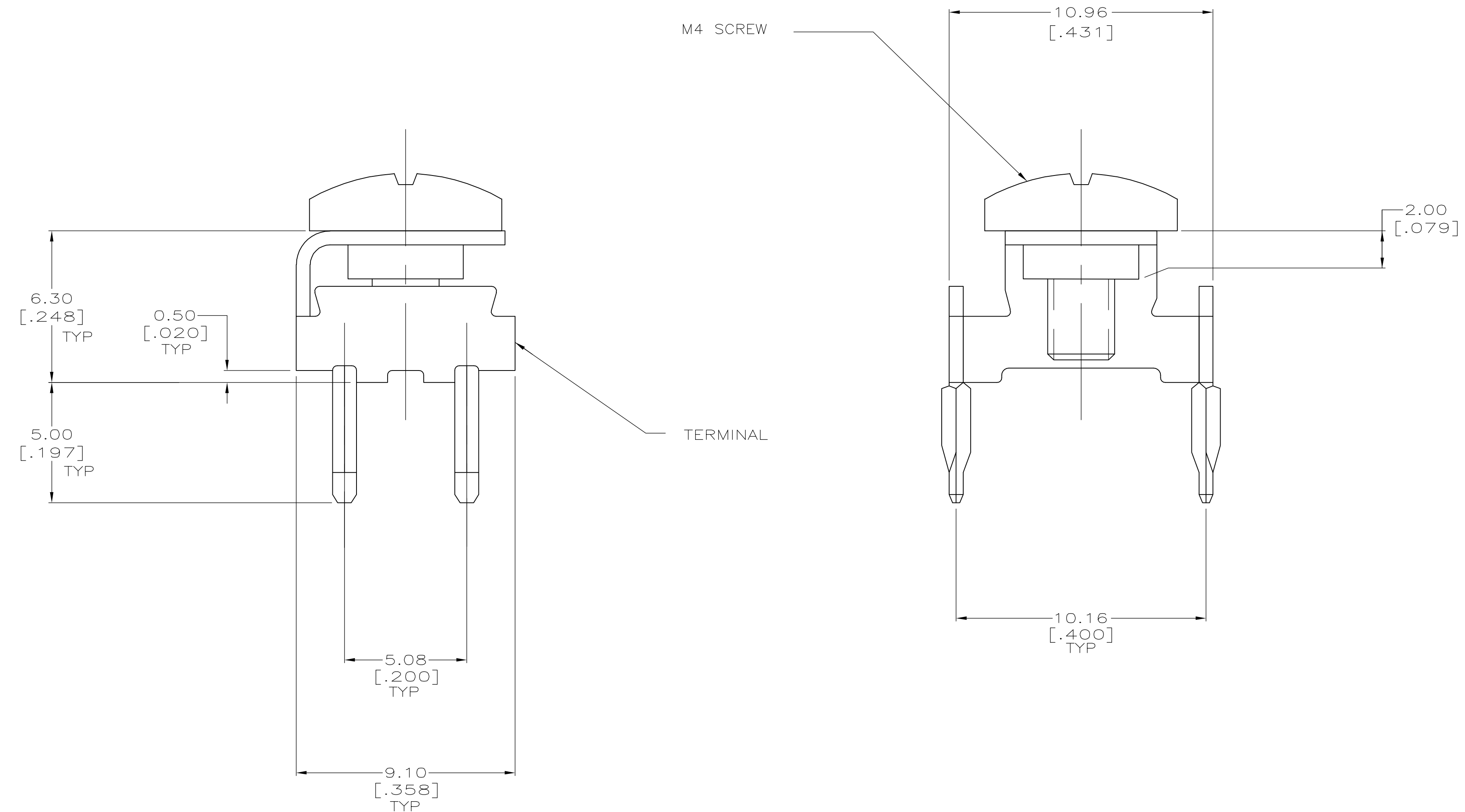

RECOMMENDED P.C. BOARD LAYOUT

- △ TERMINAL: PHOSPHOR BRONZE; SCREW: STAINLESS STEEL.
- △ 2.54μm [.000100] MIN MATTE TIN OVER 1.25μm [.000050] MIN NICKEL.
- △ PASSIVATED.

PLATED THROUGH HOLE SPECIFICATION		THIS DRAWING IS A CONTROLLED DOCUMENT.		FINISH		PART NUMBER	
DRILLED HOLE	1.6±0.025	DWN	J. ALCORTA - DOCK5 05-05-05	Tyco Electronics Corporation		5213815-1	
Cu- THICKNESS	25-75 μm	CHK	A. FRANTUM 05-05-05	Harrisburg, PA 17105-3608			
Sn- THICKNESS	4-10 μm	APVD	S. FLICKINGER 05-05-05	NAME		POWER TAP ASSY, 4 POSN	
FINISHED HOLE	1.39-1.54	PRODUCT SPEC		APPLICATION SPEC		SIZE CAE CODE DRAWING NO	
FINISHED HOLE (AFTER REFLOW)	1.36-1.54	MATERIAL	△	WEIGHT		A1 00779 C=5213815	
				CUSTOMER DRAWING		RESTRICTED TO	
				SCALE		SHEET 1 OF 1 REV A	