

4

3

2

1

THIS DRAWING IS UNPUBLISHED. RELEASED FOR PUBLICATION 20
© COPYRIGHT 20 BY TYCO ELECTRONICS CORPORATION. ALL RIGHTS RESERVED.

LOC	DIST	REVISIONS			
P	LTR	DESCRIPTION	DATE	DWN	APVD
CM	0				
	A	REVISED PER ECR 10-006756	01APR10	JR	SM
	B	REVISED PER ECR-18-000415	19JAN2018	RS	SZ

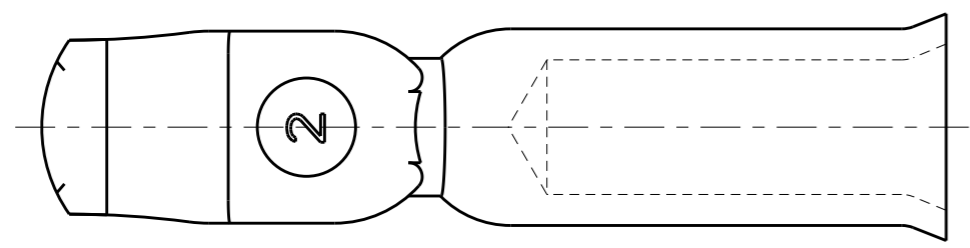
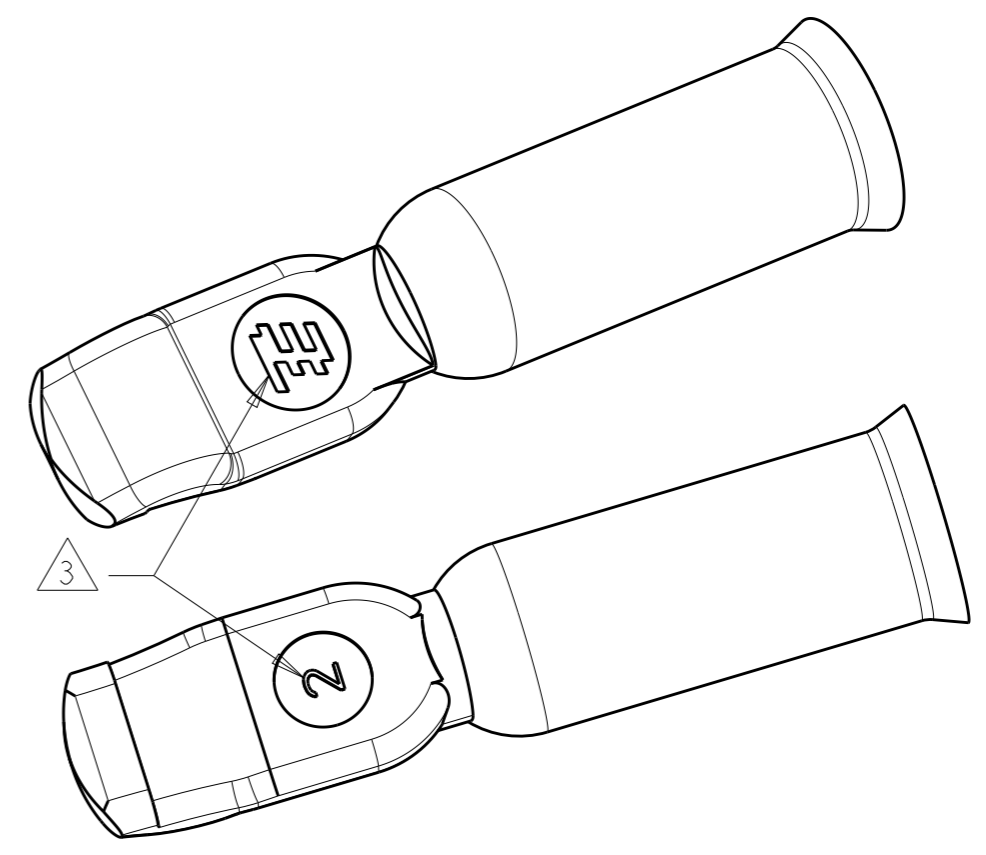
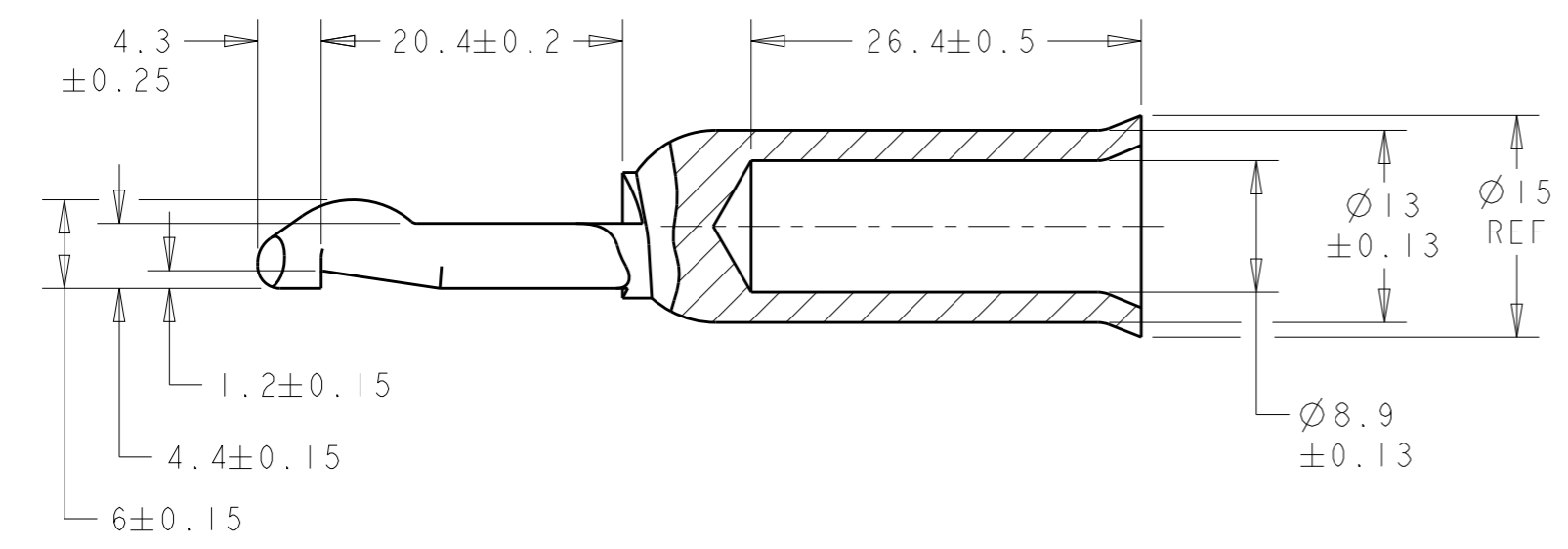
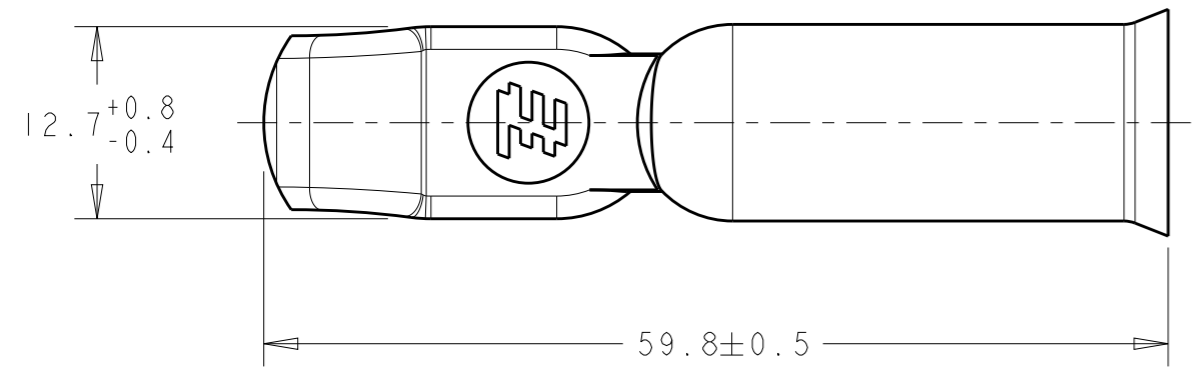

- 1. MATERIAL: COPPER ALLOY
- 2. FINISH: PLATED SILVER
- △ STAMP MARK MAY BE ROTATED

METRIC

THIS PRODUCT HAS PASSED VERIFICATION AND AGENCY APPROVALS TESTING AND IS COMPONENT RECOGNIZED PER UL 1977 AND CSA 22.2. TYCO ELECTRONICS PRODUCT QUALIFICATION TESTING IS NOT YET COMPLETED.

AS SHOWN	1604039-1
DESCRIPTION	PART NUMBER

<small>THIS DRAWING IS A CONTROLLED DOCUMENT FOR TYCO ELECTRONICS CORPORATION. IT IS SUBJECT TO CHANGE AND THE CONTROLLING ENGINEERING ORGANIZATION SHOULD BE CONTACTED FOR THE LATEST REVISION.</small>		DWN B.D.Yohn 14MAR2002 CHK W.H.Bernhart 14MAR2002 APVD W.H.Bernhart 14MAR2002		tyco Tyco Electronics Electronics Harrisburg, PA 17105-3608	
DIMENSIONS: mm 		TOLERANCES UNLESS OTHERWISE SPECIFIED: 0 PLC ±- 1 PLC ±0.3 2 PLC ±0.13 3 PLC ±0.050 4 PLC ±- ANGLES ±-		NAME CONTACT, AMP POWER SERIES 175 / 180, 2 AWG	
MATERIAL -		FINISH -		PRODUCT SPEC - APPLICATION SPEC - WEIGHT -	
CUSTOMER DRAWING				SIZE A3 CAGE CODE 00779 DRAWING NO. 1604039	RESTRICTED TO SCALE 2:1 SHEET 1 OF 1 REV B