

THIS DRAWING IS A CONTROLLED DOCUMENT.

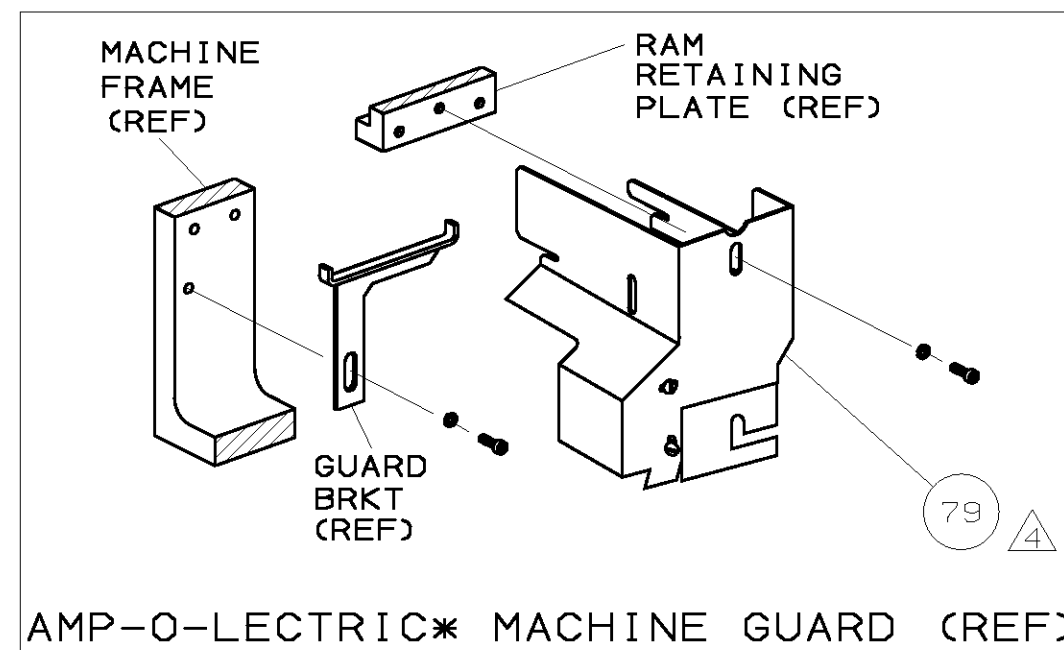

AMP-O-ELECTRIC* MACHINE GUARD (REF)

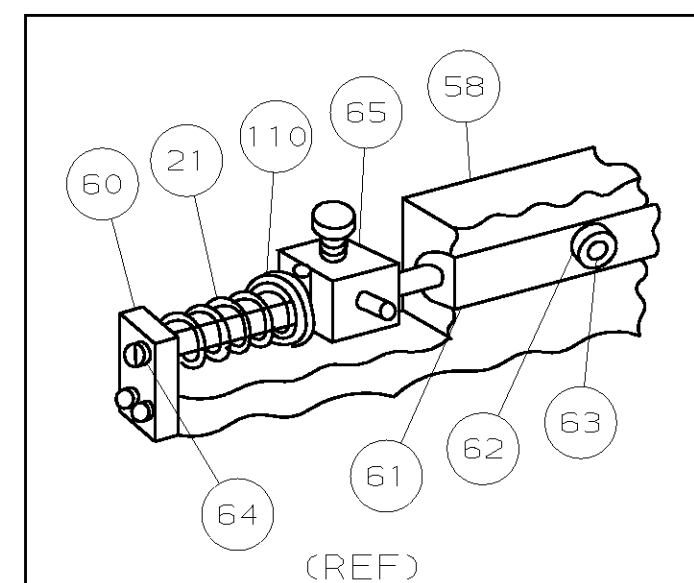
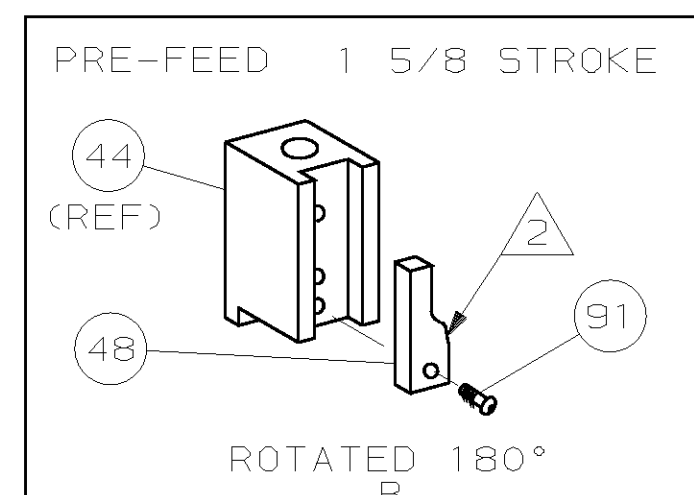
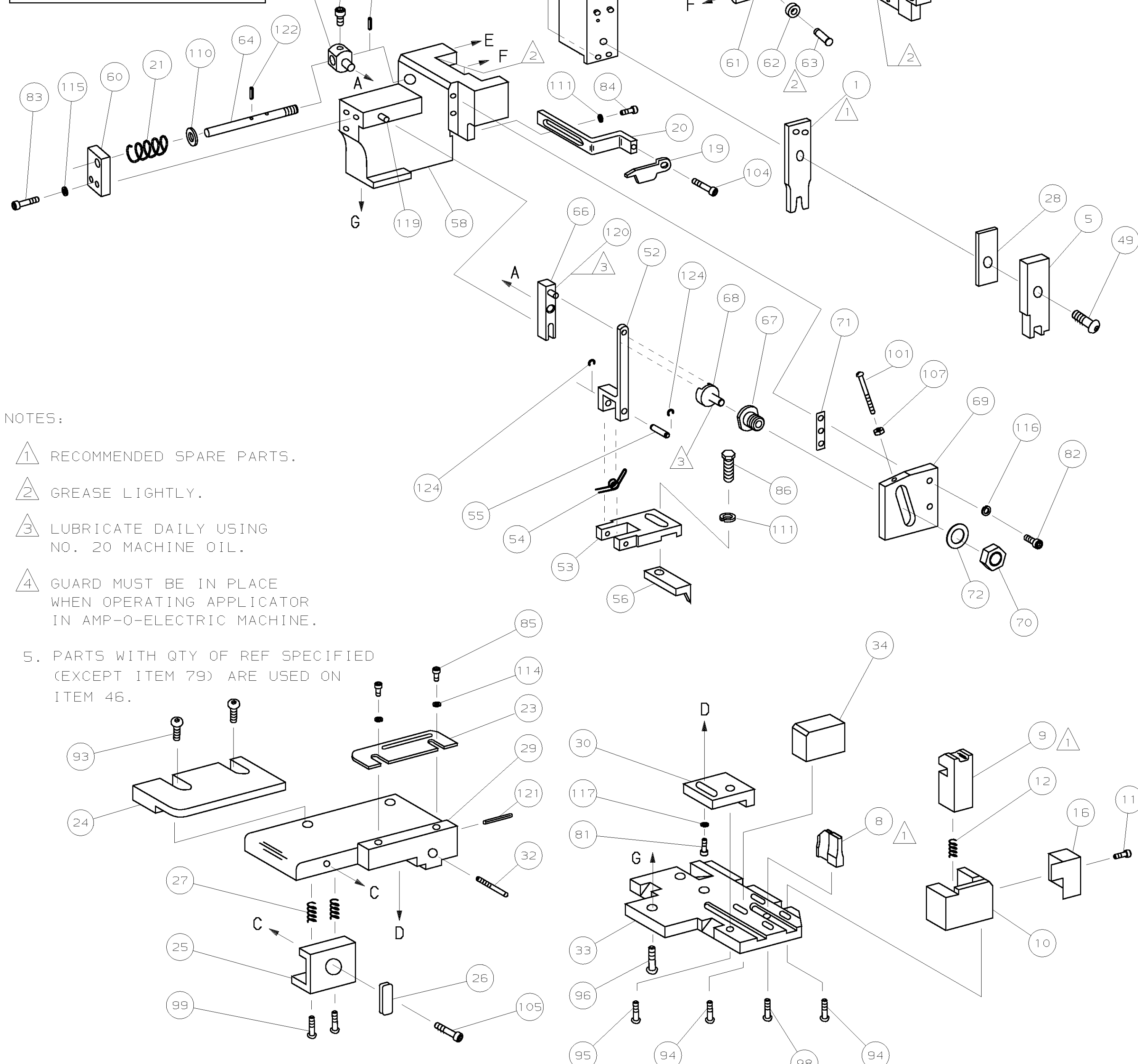

- NOTES:
- 1 RECOMMENDED SPARE PARTS.
 - 2 GREASE LIGHTLY.
 - 3 LUBRICATE DAILY USING NO. 20 MACHINE OIL.
 - 4 GUARD MUST BE IN PLACE WHEN OPERATING APPLICATOR IN AMP-O-ELECTRIC MACHINE.

5. PARTS WITH QTY OF REF SPECIFIED (EXCEPT ITEM 79) ARE USED ON ITEM 46.

THIS DRAWING IS UNRELEASED.
 RELEASED FOR PRODUCTION 21 MAR 2000
 BY AMP INCORPORATED. ALL RIGHTS RESERVED.
 © COPYRIGHT 2000
 AMP 1756 REV 3-87

AMP 1756 REV 3-87 03-SEP-04 09:37:11 us016926

REF	21045-3	RING, RET "C" (.187ø) FEED FINGER PIN	124	REF	454220-1	CAP, HOUSING	59
REF	5-21028-1	PIN, SLT SPR (.125øx.50) ADJ ROD	123	REF	454485-1	HOUSING	58
1	4-21028-0	PIN, SLT SPR (.093øx.75) ST GUIDE PL	121				57
REF	1-21030-1	PIN, DOWEL (.187øx.50) LEVER	120	1	458537-2	PAWL, FEED	56
REF	1-21030-6	PIN, DOWEL (.187øx1.25) HOUSING	119	REF	240624-1	PIN, FEED FINGER	55
				REF	691499-1	SPRING, FEED FINGER	54
1	21024-5	WASHER, LOCK (NO.10) ADJ BLOCK	117	REF	690541-1	FINGER, FEED	53
REF	21024-5	WASHER, LOCK (NO.10) ADJ PLATE	116	REF	455679-1	LEVER, TERMINAL FEED ARM	52
REF	21024-5	WASHER, LOCK (NO.10) FEED GUIDE ROD	115				51
2	21024-2	WASHER, LOCK (NO.4) FRONT STRIP GUIDE	114				50
			113	1	7-21002-9	BOLT, CRIMPER (5/16-24x1.00)	49
			112	1	690602-6	CAM, PRE-FEED 1 5/8 STROKE	48
							47
4	21024-4	WASHER, LOCK (NO.8) STRIPPER	111	1	459456-1	APPLICATOR, BASIC (SUBASSY)	46
REF	21899-4	WASHER, FLAT (5/16 DIA) SCREW ADJ	110	1	690191-1	PLUG, NYLON	45
			109	1	455673-1	RAM	44
			108	1	690125-1	WASHER, LAMINATED	43
REF	21018-5	NUT, HEX (6-32) FEED ADJ	107	1	690124-1	WASHER, RAM	42
			106	1	690223-1	DISC, SPACER	41
1	22353-8	SCR, SHLD (.187øx.25) DRAG LEVER	105	1	23241-6	BALL, STEEL	40
1	456567-1	SCR, SHLD (.188øx.125) STRIPPER	104	1	690170-1	SPRING, COMPRESSION	39
1	21009-2	SCR, SKT SET (1/4-20x.25) LOC-WEL) RAM	103				38
2	21017-2	SCR, DRIVE (#2x.19) ID PLATE	102	1	1-690141-0	DISC, WIRE	37
REF	6-23715-5	SCR, PAN HD (6-32x1.50) FEED ADJ	101	1	22480-5	WASHER, SPRING	36
1	461264-1	PLATE, IDENTIFICATION	100	1	690212-1	POST, RAM	35
2	3-21002-0	SCR, BHC (10-32x.88) DRAG	99	1	1-690786-3	SUPPORT, TERMINAL	34
1	22733-8	SCR, BHC (8-32x.38) LOC-WEL) ANVIL	98	REF	455675-1	PLATE, BASE	33
REF	2-21002-9	SCR, BHC (10-32x.75) CAP	97	1	690432-3	SCREW, ADJUSTMENT	32
REF	2-22733-8	SCR, BHC (1/4-20x.62) HOUSING	96				31
REF	2-21002-7	SCR, BHC (10-32x.50) SG ADJ BLOCK	95	REF	455689-1	BLOCK, STRIP GUIDE ADJ	30
4	2-21002-2	SCR, BHC (8-32x.50) SHEAR	94	1	458144-1	PLATE, STRIP GUIDE	29
2	2-21002-2	SCR, BHC (8-32x.50) R STRIP GUIDE	93	1	2-455888-5	SPACER, FRONT SHEAR DEP	28
			92	2	1-22284-0	SPRING, DRAG	27
1	1-21002-7	SCR, BHC (6-32x.38) CAM	91	1	240793-1	LEVER, DRAG RELEASE	26
			90	1	240792-1	DRAG, STOCK	25
			89	1	9-690504-7	GUIDE, STRIP (REAR)	24
			88	1	690438-1	GUIDE, STRIP (FRONT)	23
							22
2	2-21000-5	SCR, SKT CAP (8-32x.25) DEP-HOLD DOWN	87				21
1	2-22603-0	SCR, HEX HEAD (8-32x.31) FEED FINGER	86	REF	4-22284-9	SPRING, FEED RETURN	20
2	1-21000-3	SCR, SKT CAP (4-40x.25) F STRIP GUIDE	85	1	458950-1	ARM, STRIPPER	19
1	2-21000-7	SCR, SKT CAP (8-32x.50) STRIPPER	84	1	458949-1	STRIPPER	18
REF	3-21000-7	SCR, SKT CAP (10-32x.75) FEED ROD GD	83	1	460801-4	HOLDER, TERMINAL	17
REF	3-21000-6	SCR, SKT CAP (10-32x.62) FEED ADJ BLK	82				16
1	3-21000-4	SCR, SKT CAP (10-32x.38) SG ADJ BLK	81	1	691667-3	GUARD, CHIP (FRONT)	15
REF	3-21000-4	SCR, SKT CAP (10-32x.38) PIVOT BLOCK	80				14
REF	455755-1	GUARD, WINDOW	79				13
			78				12
			77	1	5-22280-0	SPRING, SHEAR	11
			76	1	690461-1	STOP, SHEAR	10
			75	1	690459-5	HOLDER, SHEAR (FRONT)	9
			74	1	454276-8	SHEAR, FLOAT (FRONT)	8
			73	1	5-683403-0	ANVIL	7
			72				6
			71				5
			70	1	1-455889-4	DEPRESSOR, SHEAR (FRONT)	4
			69				3
			68				2
			67				1
			66	1	456411-2	CRIMPER, WIRE	
			65				
			64				
			63				
			62				
			61				
			60				
			59				
			58				
			57				
			56				
			55				
			54				
			53				
			52				
			51				
			50				
			49				
			48				
			47				
			46				
			45				
			44				
			43				
			42				
			41				
			40				
			39				
			38				
			37				
			36				
			35				
			34				
			33				
			32				
			31				
			30				
			29				
			28				
			27				
			26				
			25				
			24				
			23				
			22				
			21				
			20				
			19				
			18				
			17				
			16				
			15				
			14				
			13				
			12				
			11				
			10				
			9				
			8				
			7				
			6				
			5				
			4				
			3				
			2				
			1				

QTY	PART NO	DESCRIPTION	ITEM NO
TERM APPL SPEC 114-6044			
CRIMPING DATA			
PAD LTR	CRIMP HEIGHT	WIRE SIZE	WIRE STRIP LENGTH
A	.098	14	
B	.091	16	
C	.087	18	
D	NOT USED		
CRIMP SIZE	TYPE	FEED	APPL INST
WIRE .140	F	.730	AI 8040
INSUL -	-		
WIRE RANGE 14-18	INSULATION RANGE -	MACHINE NO 354500-1	
REMARKS			
BENCH MODEL G PRE-FEED			

SET UP GAGE	10-1	458637-1	L1410
DR 6-3-97	APP 6-3-97	T.ELBIN	
C.ERISMAN	REL 12/1/97	B. MORGAN	
B1	ECN 0150-1153-04	TE 9-04	
B	0150-0209-00	CE MAR00	
A	REVISED	CE 11-97	
NAME: MINIATURE QUICK CHANGE APPLICATOR			
SIDE FEED (INNERGY)			