

## Interactive Catalog Replaces Catalog Pages

Honeywell Sensing and Control has replaced the PDF product catalog with the new **Interactive Catalog**. The **Interactive Catalog** is a power search tool that makes it easier to find product information. It includes more installation, application, and technical information than ever before.



**Click this icon to try the new  
Interactive Catalog.**

---

### **Sensing and Control**

Honeywell Inc.

11 West Spring Street

Freeport, Illinois 61032



GENERAL INFORMATION

The WW Series switching mechanism is a non-snap double break shorting bar type construction. One, two or three circuit versions are available.

The three-circuit unit has two poles. The term "pole" denotes the number of completely separate circuits that can pass through the switch at one time. On a three-circuit switch in the unoperated condition (see drawing) circuit # 2 is closed and circuit # 1 and # 3 are open. As the plunger is depressed, circuit # 2 opens and circuit # 1 and # 3 are closed. The switch is two-pole since it makes and breaks two separate circuits (# 1 and # 3). When the plunger is released, circuit # 1 and # 3 are broken and circuit # 2 is closed.

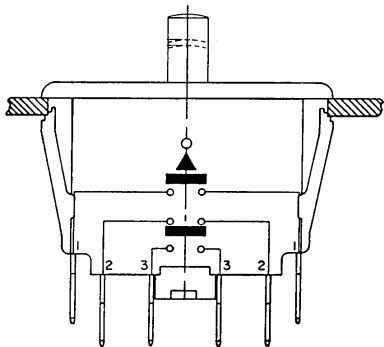

FEATURES

- Snap-in panel mounting
- Variety of terminal sizes
- Accepts quick-connect insulated terminals
- 10-16 amps electrical rating at 125 or 250 VAC depending on number of circuits and termination
- Same panel cutout as double-pole DM switch
- Quick-connect D7 and D9 termination complies with VDE requirements for 3mm air gap
- Switches with plunger guards and D7, D9 terminations are VDE approved
- UL recognized, CSA certified
- Meets UL's 100,000 operations requirement for operator-accessible interlock switches
- Covered under UL standard 508 Industrial Motor Controls

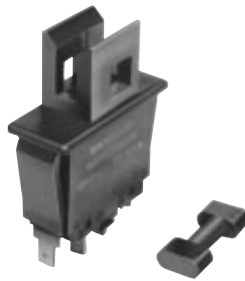

Plunger guard version and cheat-key.



With cheat-key installed.

WWs are available with or without a plunger guard. A cheat-key can be furnished for use with the plunger guard to maintain the switch plunger in the depressed condition (see photos →).

MOUNTING DIMENSIONS (For reference only)

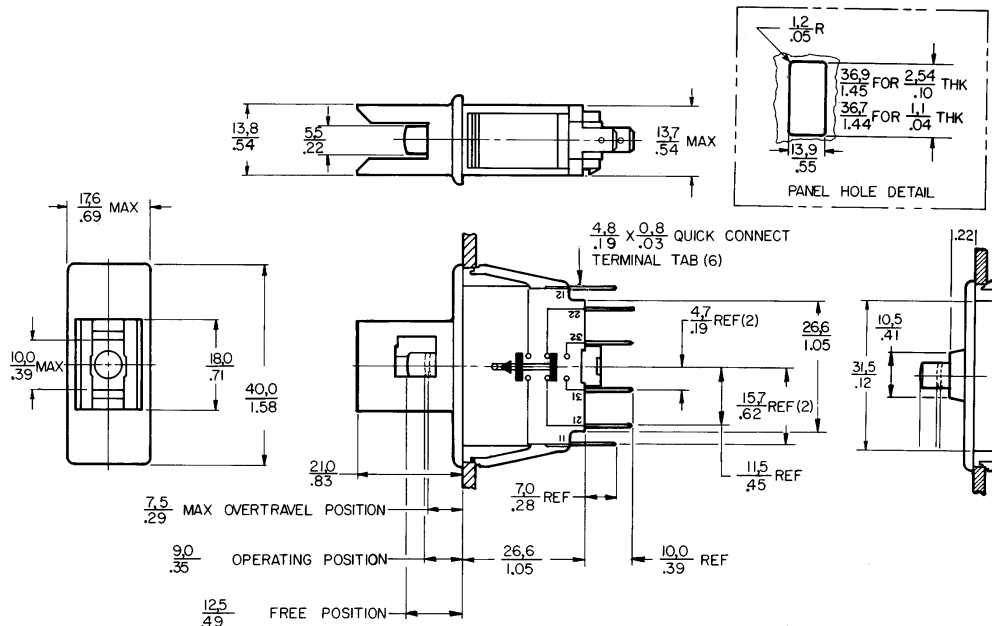

NOTE: Terminals will accept quick-connect receptacles available from AMP, Hollingsworth and others.

### ELECTRICAL RATINGS

UL and CSA \* Asterisked loads tested for 100,000 cycles

Electrical Rating	3-Pole	Electrical Rating	2-Pole	Electrical Rating	1-Pole
C	Contacts 1-1, 3-3: †* 15A, 125VAC, *10A, 250VAC: ½ hp @ 125, 250VAC; 3A "L", 125VAC; 150VA pilot duty @ 125/250VAC	A	Contacts 1-1, 3-3: †* 16A, 125/250VAC: ½ hp, 125/250 VAC; 3A "L", 125VAC; 150 VA pilot duty 125/250 VAC; *2A, 24VDC	B	Contacts 1-1: * 16A, 125/250VAC; ¾ hp, 125/250VAC; 150VA pilot duty 125/250 VAC; 3A, "L", 125VAC
D	Same as C with 0.1A, 125 VAC; *2A, 24VDC	F	Same as A with 0.1A, 125VAC		
E	†Contacts 2-2: 0.1A, 125VAC/VDC	G	*5A, 125VAC, 2A, *24VDC		

### VDE †

Flagged loads tested for 10,000 cycles

Circuits # 1 and # 3 †16 (4)A, 250VAC  Circuit # 2 †0.1 (0.05) A, 250VAC
--

### ORDER GUIDE

Catalog Listings*	Circuitry	Electrical Rating	Plunger Guard
WW1A04A-D7	# 1 - N.O.	A	No
WW1G03A-D7	# 1 & # 3 - N.O.	A	No
WW1K06D-D7	# 1 & # 3 - N.O. # 2 - N.C.	C E	No
WW1G02A-D9	# 1 & # 3 - N.O.	A	Yes
WW1K05D-D9	# 1 & # 3 - N.O. # 2 - N.C.	C E	Yes

Cheat-key: Catalog Listing 15PA256-WW

### Termination Options

To order other termination options, substitute the option letter and number at the end of the catalog listing.

D7: .187 x .032 in. (4,75 x 0,8 mm).

D8: .187 x .020 in. (4,75 x 0,5 mm).

D9: .250 x .032 in. (6,35 x 0,8 mm).

D7 and D9 terminals are VDE certified.  
VDE limits D7 terminals to 12A.

### CATALOG LISTING CODE

WW  
Type

1  
Action

K  
Circuitry

00  
Variations

D  
Elec. Rating

- D8  
Termination

Door Switches