



ESENSE IP54

CO2 Sensor with LCD & IP54 Rated Enclosure

The ESENSE Duct series monitors the carbon dioxide (CO₂) levels in industrial, school, and office type environments. The concentration of CO₂ is a good indication of the overall indoor air quality. The ESENSE Series is based on a single beam non-dispersive infrared technology and is a cost-optimized solution for the climate control of buildings and other processes. In addition, ABC software eliminates the need for manual calibration. The ESENSE Series measures the CO₂ concentration in the ambient air up to 2,000 ppm and converts the data into an analog output. This data can be used in conjunction with a Building Automation or Demand Control Ventilation System to decrease energy consumption while creating a healthier indoor climate.

Applications: Commercial Office Buildings, Hospitals & Schools

The ESENSE IP54 Series is covered by ACI's Five (5) Year Limited Warranty. The warranty can be found in the front of ACI's Sensors & Transmitters catalog, as well as on ACI's web site, workaci.com.

PRODUCT SPECIFICATIONS

Supply Voltage:	24 VAC/VDC ±20%; 50/60Hz (Half-wave rectified)
Power Consumption:	<1W
Electrical Connections:	0.00232 in ² (1.5 mm ²) screw terminals
Operating Temperature:	32°F to 122°F (0°C to 50°C)
Operating RH:	0 – 95% RH Non-condensing
Warm-Up Time:	1 minutes (@ full specs 15 minutes)
Accuracy¹:	±30 ppm and ±3% of reading
Repeatability:	±20 ppm ±1% of measured value
Annual Zero Drift:	± 0.3% of measurement range
Operating Pressure:	+1.6% per 0.145 psi (1 kPa) deviation from normal pressure (1 Atmosphere = 14.7 psi (1.013 KPa))
Sensing Method:	Single beam Non-dispersive Infrared (NDIR)
Sensor Life²:	>15 years
Response Time (T1/e):	<10 seconds @ 30 cc/min flow rate, < 3 minutes diffusion time
Operating Environment:	Residential, Commercial and Industrial spaces
Sensing Range:	0 to 2000 ppm
Extended CO2 Ranges:	Up to 10,000 ppm (factory set or SADK Kit required)
Extended Range Accuracy >2,000 PPM:	+/- 30 ppm and +/- 5% of reading
Display (Optional):	4 digits, 7 segments LCD with ppm indicator
Calibration³:	Senseair ABC algorithm (Automatic Baseline Correction)
Output:	Standard: Out 1: 0-10V for 0-2000 ppm Out 2: 2-10V or 4-20 mA for 0-2000 ppm
Storage:	-40 to 158°F (-40 to 70°C) Non-display, -4 to 122°F (-20 to 50°C) Display Duct Box: IP65 rated, PC & ABS blend, Flammability Rating UL94V-0 Cover: Makrolon® 6555 plastic, Flammability Rating UL94V-0 Pipe: PC & ABS blend, Flammability Rating UL94V-0
Enclosure:	
Room Dimensions:	(H) 5.95" (151.8 mm) x (W) 3.33" (84.6 mm) x (D) 1.85" (47 mm)
Product Weight:	0.80 lbs (0.36 kg)
Agency Approvals:	EMC Directive 2014/30/EC RoHS Directive 2011/65/EU RoHS 3 Directive 2015/863/EU

Note 1: Accuracy is defined after minimum three (3) ABC periods (1 period = 8 days) of continuous operations | **Note 2:** In normal Indoor Air Quality (IAQ) applications | Corrosive environments are excluded | Changes can be made using the SADK Calibration Kit and UIP5 software | **Note 3:** Building CO₂ levels must drop to 400 ppm some time during the week for ABC to work properly. If the building is occupied 24 hrs/day, ABC must be turned off





DIMENSIONAL DRAWING

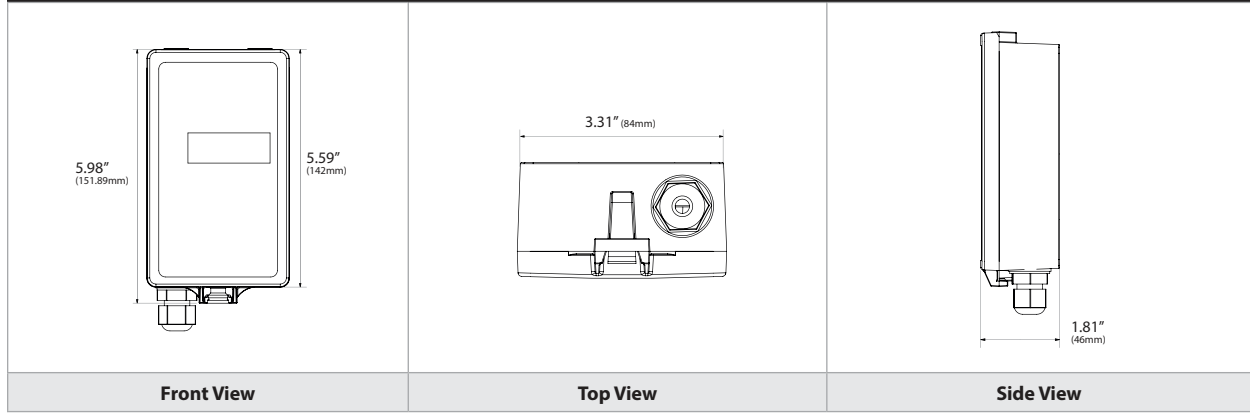

STANDARD ORDERING

ACI Model #	Item #	Description
ESENSE-IP54-LCD	130169	CO2 Duct Mount, 0-10 VDC, 2-10 VDC or 4-20 mA Output

ACCESSORIES ORDERING

ACI Model #	Item #	Description
A/CUSTOM CAL GAS*	140970	Custom Calibration
SADK	130502	SADK Calibration Kit
UIP5	----	Free Software Download (Contact ACI)

Note*: Contact ACI's Technical Support for custom calibration ranges