

PART NUMBER	REVISION	DESCRIPTION	FEED TYPE
2266461-1	G	FINE CRIMP HEIGHT ADJUST	MECHANICAL
2266461-2	G	FINE CRIMP HEIGHT ADJUST	PNEUMATIC
7-2266461-1	G	MECHANICAL AND CRIMP TOOLING KIT	MECHANICAL
7-2266461-2	G	PNEUMATIC AND CRIMP TOOLING KIT	PNEUMATIC
7-2266461-7	G	CRIMP TOOLING KIT	-

ATLANTIC VERSION TERMINATOR INTERFACE ADAPTER

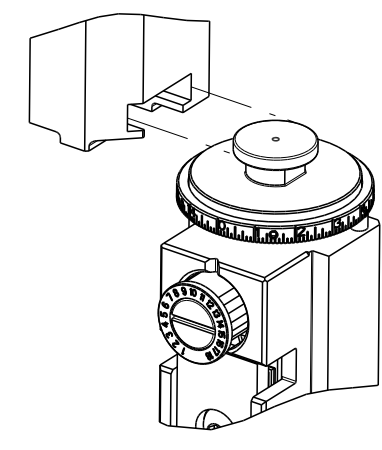

APPLICATOR DATA		
CRIMP	SIZE	TYPE
WIRE	1.78 mm [.070]	F
INSUL	1.78 mm [.070]	O

APPLICATOR INSTRUCTIONS 408-35042

TERMINAL DATA: BOSCH TERMINAL TE CRIMP SPECIFICATION			
TERMINAL NAME: TERMINAL MATRIX 1.2			
WIRE STRIP LENGTH	INSULATION DIAMETER RANGE		
3.20-3.80 mm [.126-.150 IN]	Ø1.70-2.10 mm [.067-.083 IN]		
TERMINAL APPLICATION SPECIFICATION	BOSCH 1928 A00 47M-EN		
TERMINALS APPLIED			
TE TERMINAL	BOSCH TERMINAL	TE TERMINAL	BOSCH TERMINAL
2113044-1	1928498674	2113044-3	1928498680
2113044-2	1928498677	2137409-1	1928498674

WIRE SIZE	CRIMP HEIGHT mm [INCH]	CRIMP HEIGHT REFERENCE SETTING
1.00mm2	1.13+/-0.03 [.044+/- .001]	6.6
0.75mm2	1.03+/-0.03 [.041+/- .001]	7.6

- 1. RECOMMENDED SPARE PARTS
- 2. REFER TO SUPPLIED INSTRUCTION SHEET FOR CLEANING, LUBRICATION AND STORAGE OF APPLICATOR.
- 3. APPLY PART NUMBER 2-23419-6 LOCTITE TO THREADS OF ITEM 242.
- 4. CRIMP HEIGHT REFERENCE SETTING WAS THE SETTING USED WHEN THE APPLICATOR WAS QUALIFIED AT THE FACTORY. ADJUSTMENT MAY BE NECESSARY WHEN RUNNING APPLICATOR IN THE FIELD.
- 5. UNLESS SPECIFIED OTHERWISE TORQUE VALUES SHALL BE USED PER DOCUMENT, 101-35000.
- 6. TERMINAL LUBRICANT IS RECOMMENDED.

***WARNING**
 ON INSTALLATION, SET WIRE DISC TO CRIMP HEIGHT REFERENCE SETTING FOR LARGEST WIRE SIZE. CRIMP HEIGHT REFERENCE SETTINGS GREATER THAN THE VALUE SHOWN MAY CAUSE DAMAGE TO THE CRIMP TOOLING, REFER TO THE INSTRUCTION SHEET FOR PROPER SETUP AND ADJUSTMENTS.

ATLANTIC VERSION
 Shown on sheets 1 of 4 & 2 of 4
 (Pacific version shown on sheets 3 of 4 & 4 of 4)

LOC	DIST	REVISIONS					
A	66	P	LTN	DESCRIPTION	DATE	OWN	APVD
		D		ECR-18-011513	19JUL2018	KH	TE
		E		ECR-18-013196	20AUG2018	FZ	KZ
		F		ECR-19-004178	15MAR2019	FZ	YY
		G		ECR-19-015146	26SEP2019	TB	RK

-	2	2	2	2	2168083-1	SCR, SKT HD CAP, RoHS, M3 X 8.0	269	
-	1	1	1	1	1633782-4	FENCE	267	
-	1	-	1	-	2119641-1	FEED CAM, AIR FEED	248	
-	1	1	1	1	2119082-5	CAM, SNAIL, INSULATION ADJUSTMENT	244	
-	1	1	1	1	2079764-1	WASHER, WAVE SPRING, CREST-TO-CREST	243	
3	-	1	1	1	2119083-1	RETAINER, INSULATION DIAL	242	
-	1	1	1	1	7-18023-7	SCR, SKT HD CAP M3 X 4.0	241	
-	-	1	-	1	2119580-1	MECHANICAL FEED ASSEMBLY	239	
-	1	-	1	-	2844940-1	AIR FEED MODULE	238	
-	REF	REF	REF	REF	994970-2	COUNTER, MAGNETIC	164	
6	-	1	1	1	2119955-1	ASSY, LUBRICATOR, SIDE FEED	113	
-	1	1	1	1	2844908-1	SCREW, LOCKING	99	
-	1	1	1	1	2844907-1	POST, LOCKING	98	
-	1	1	1	1	455888-7	SPACER, CRIMPER	82	
-	1	1	1	1	1803607-3	DOCUMENTATION PACKAGE	71	
-	1	1	1	1	2119791-5	DEPRESSOR, WIRE	70	
-	1	1	1	1	2119740-1	TAG, IDENTIFICATION	67	
-	2	2	2	2	2168078-1	SCREW, DRIVE, RH, RoHS, 2 x .188	66	
-	1	1	1	1	2168083-2	SCR, SKT HD CAP, RoHS, M4 X 8.0	60	
-	1	1	1	1	5-18022-5	SCR, HEX HD CAP, M4 X 6.0	59	
-	1	1	1	1	1338685-1	PAWL, FEED	56	
-	4	4	4	4	2168083-3	SCR, SKT HD CAP, RoHS, M4 X 12.0	54	
-	2	2	2	2	2-2168083-5	SCR, SKT HD CAP, RoHS, M4 X 14	53	
-	1	1	1	1	1803382-1	HOLD DOWN, SPRING LOADED	50	
-	1	2	1	2	18023-9	SCR, SKT HD CAP M4 X 6.0	49	
-	-	1	-	1	2119652-1	FEED CAM, PRE FEED	48	
-	-	1	-	1	2119653-1	FEED CAM, POST FEED	47	
-	1	1	1	1	1803583-9	APPLICATOR BASIC ASSEMBLY, SF	46	
-	1	1	1	1	1803515-1	RAM ASSEMBLY, SF ATLANTIC	44	
-	1	1	1	1	1803602-1	SCR, BHSC, RoHS (M8 X 25)	41	
-	1	1	1	1	2-1752356-0	SUPPORT, TERMINAL	34	
-	2	2	2	2	2079383-5	SCR, BHSC, RoHS (M4 X 20)	33	
-	2	2	2	2	2-2844962-6	SPACER, CYLINDRICAL, STRIP GUIDE	30	
-	1	1	1	1	2844992-1	ASSEMBLY, STRIP GUIDE	29	
-	1	1	1	1	455888-3	SPACER, CRIMPER	28	
-	1	1	1	1	1320928-2	STRIP GUIDE	24	
-	1	1	1	1	2168083-2	SCR, SKT HD CAP, RoHS, M4 X 8.0	21	
-	2	2	2	2	1-18028-2	WASHER, FLAT, REG M4	20	
-	1	1	1	1	2119533-1	STRIPPER, SIDE FEED	19	
1	-	1	1	1	2119806-1	INSERT, SHEAR	13	
-	1	1	1	1	3-22280-3	SPRING, COMPRESSION	12	
-	1	1	1	1	1-356885-4	STOP, SHEAR	11	
1	-	1	1	1	2119805-1	SHEAR HOLDER, FRONT	10	
1	-	1	1	1	1803095-1	FLOATING SHEAR, FRONT	9	
1	2	2	1	1	6-1633620-3	ANVIL, COMBINATION	8	
-	1	1	1	1	4-240641-6	SPACER	7	
-	-	-	-	-	-	-	6	
-	1	1	1	1	2119757-4	DEPRESSOR, SHEAR	5	
-	1	1	1	1	1-238011-9	BLOCK, CRIMPER SPACER	4	
1	2	2	1	1	5-1803019-0	CRIMPER, INSULATION O	3	
-	-	-	-	-	-	-	2	
1	2	2	1	1	3-456404-2	CRIMPER, WIRE PREMIUM	1	
-	77	-72	-71	-2	-1	PART NO	DESCRIPTION	ITEM NO

DIMENSIONS: mm 		TOLERANCES UNLESS OTHERWISE SPECIFIED: 0 PLC ± 1 PLC ± 2 PLC ± 3 PLC ± 4 PLC ± ANGLES ± FINISH		DWN: STAKEM 25AUG2014 CHK: G. BAILEY 25AUG2014 APVD: T. ELBIN 25AUG2014	TE Connectivity Harrisburg, PA 17105-3608
MATERIAL:		WEIGHT:		NAME: Ocean Side Feed Applicator	
CUSTOMER ACCESSIBLE PRODUCTION DRAWING		SCALE: 1:2		SHEET 1 OF 4 REV G	

LOC	DIST	REVISIONS					
A	66	P	LYN	DESCRIPTION	DATE	DWN	APVD
		-		SEE SHEET 1	-	-	-

FEED TYPE MECHANICAL

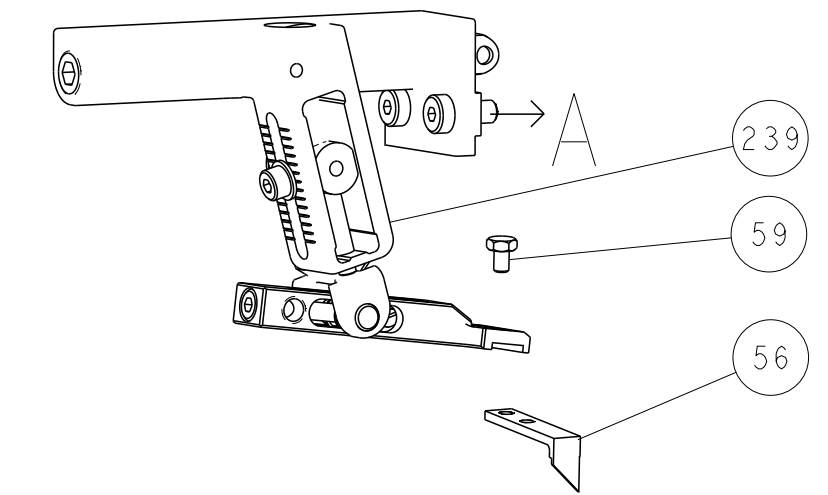

PNEUMATIC

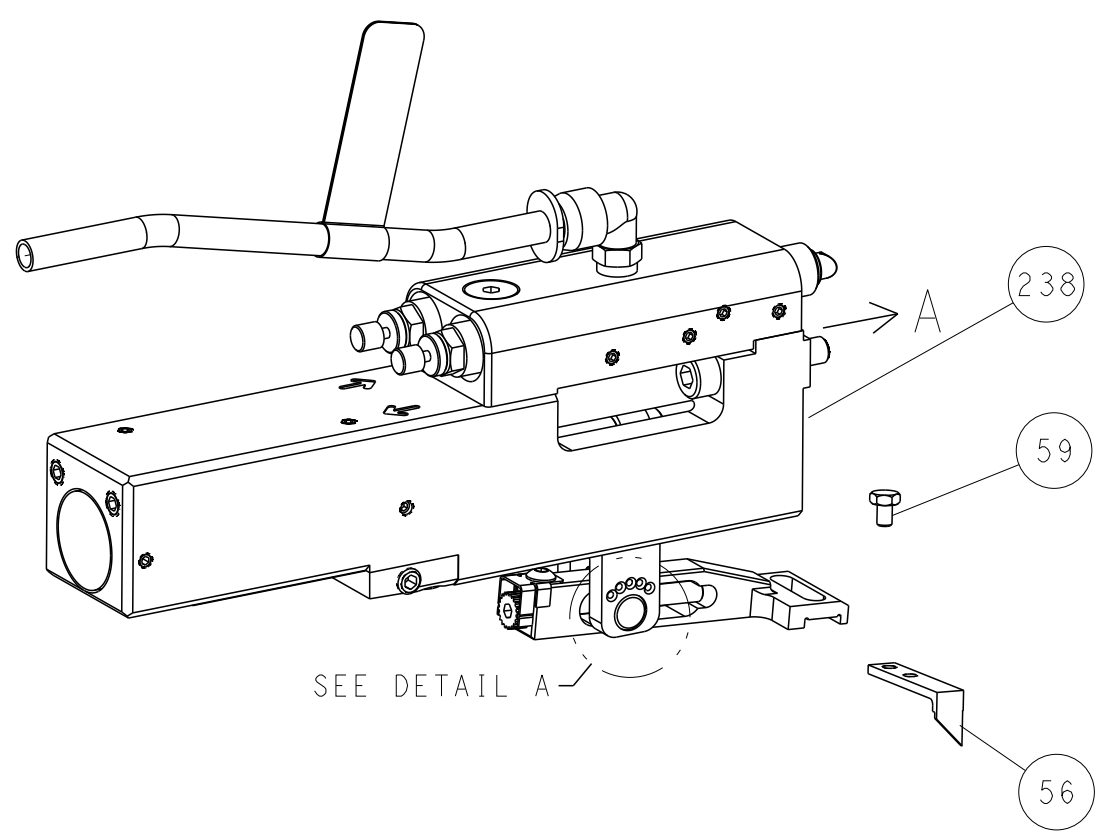

FEED SPRING SETTING POSITION (SHOWN FROM REAR SIDE)

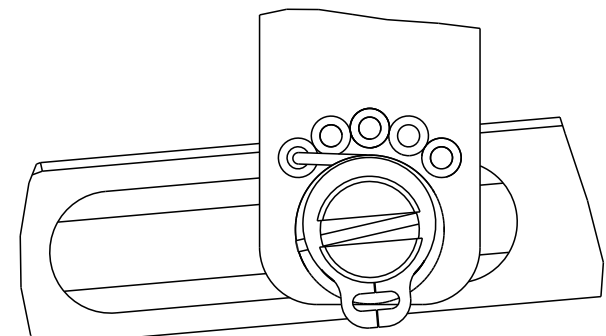

DETAIL A

CAM POSITIONS

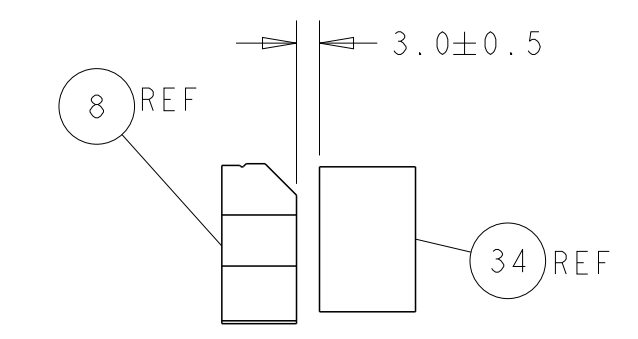
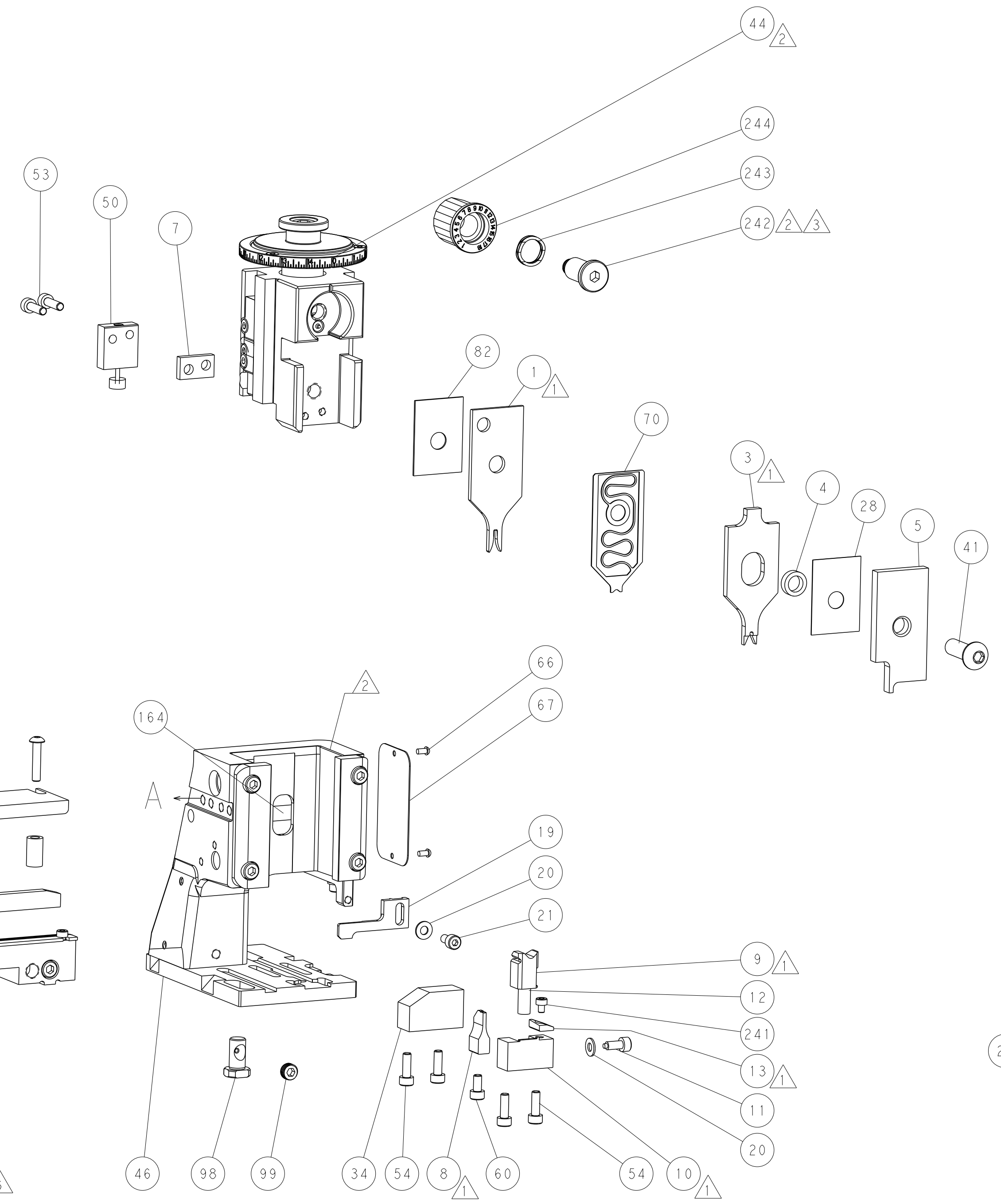
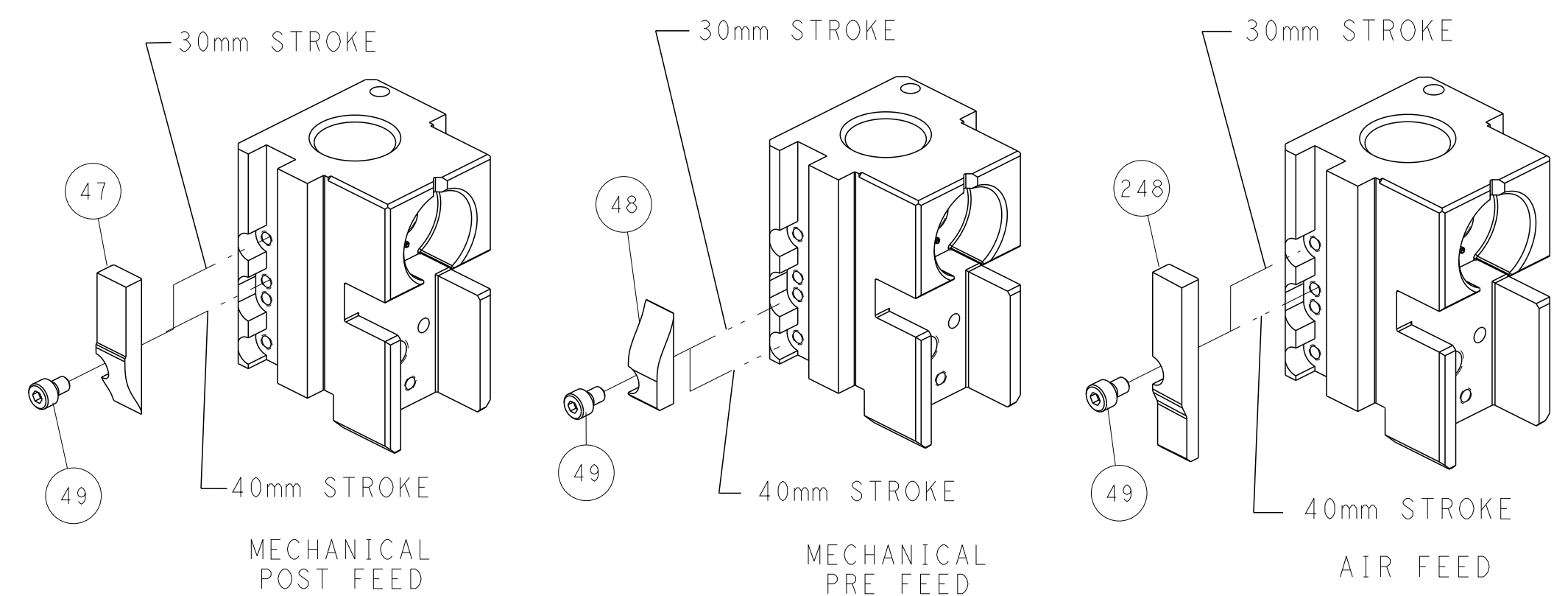

TERMINAL SUPPORT LOCATION

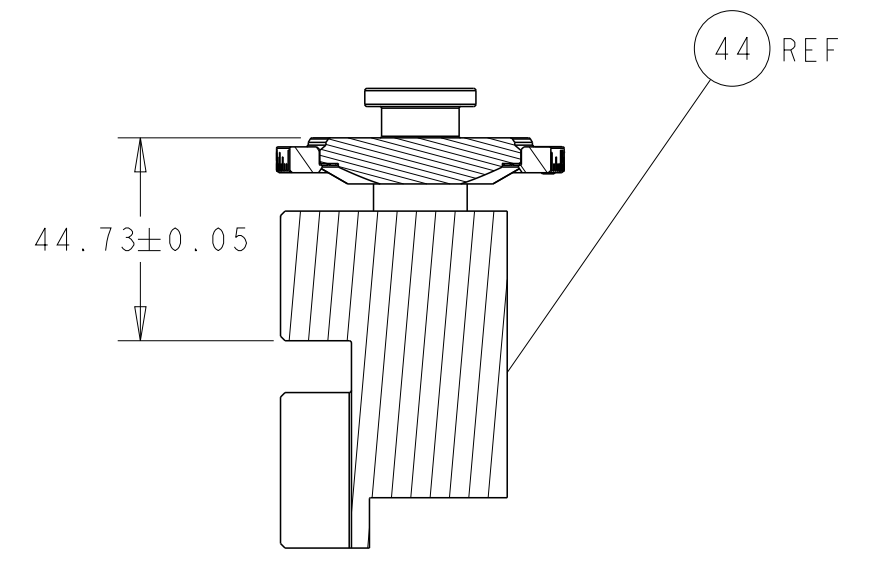

RAM SET-UP

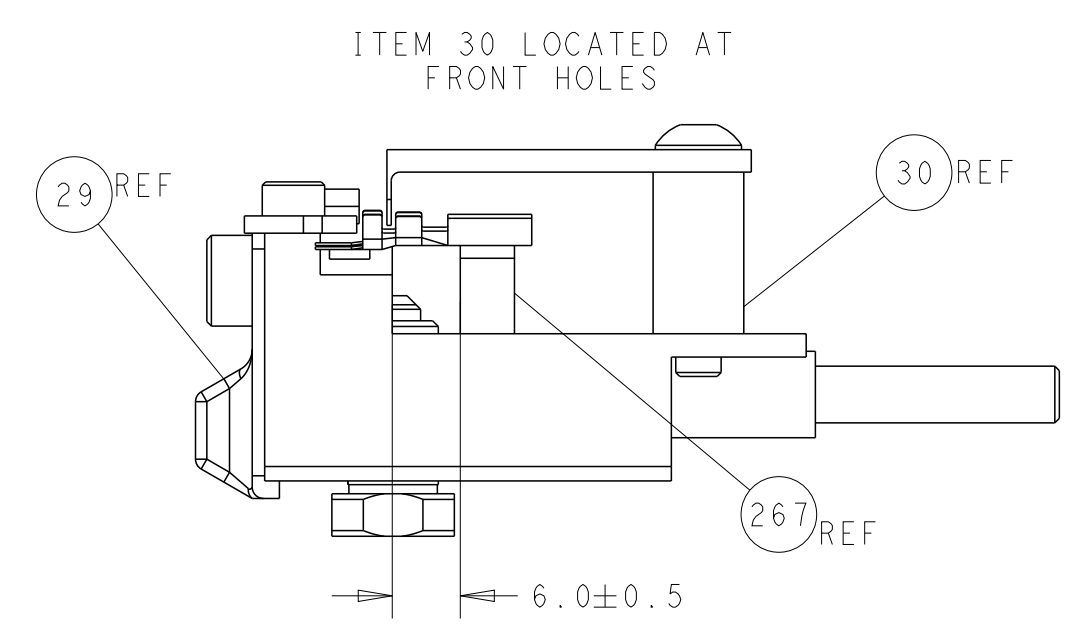

FEED TRACK POSITION GUIDE BY INSULATION BARREL

ATLANTIC VERSION
 Shown on sheets 1 of 4 & 2 of 4
 (Pacific version shown on sheets 3 of 4 & 4 of 4)

<small>THIS IS DRAWING IS UNPUBLISHED. RELEASED FOR PUBLICATION BY TYCO ELECTRONICS CORPORATION. ALL RIGHTS RESERVED.</small>		DWN: STAKEM 25AUG2014 CHK: G. BAILEY 25AUG2014 APVD: T. ELBLIN 25AUG2014	TE Connectivity Harrisburg, PA 17105-3608
DIMENSIONS: mm TOLERANCES UNLESS OTHERWISE SPECIFIED: 0 PLC ± 1 PLC ± 2 PLC ± 3 PLC ± 4 PLC ± ANGLES FINISH		NAME: Ocean Side Feed Applicator SIZE: A1 CAGE CODE: 00779 DRAWING NO: 2266461	RESTRICTED TO: - SCALE: 1:2 SHEET: 2 OF 4 REV: G
MATERIAL: - FINISH: -		WEIGHT: - Customer Accessible Production Drawing	SHEETS 3 & 4 ARE NOT REQUIRED FOR ATLANTIC VERSION

PART NUMBER	REVISION	DESCRIPTION	FEED TYPE
2-2266461-1	G	FINE CRIMP HEIGHT ADJUST	MECHANICAL
2-2266461-2	G	FINE CRIMP HEIGHT ADJUST	PNEUMATIC
7-2266461-7	G	CRIMP TOOLING KIT	-

PACIFIC VERSION TERMINATOR
INTERFACE ADAPTER

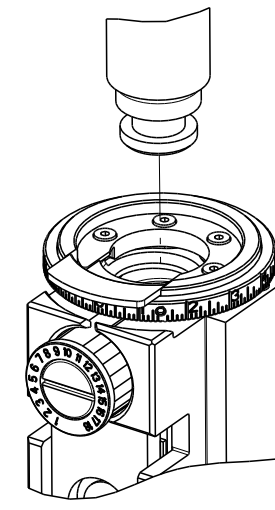

APPLICATOR DATA		
CRIMP	SIZE	TYPE
WIRE	1.78 mm [.070]	F
INSUL	1.78 mm [.070]	O

APPLICATOR INSTRUCTIONS
408-35042

TERMINAL DATA: BOSCH TERMINAL TE CRIMP SPECIFICATION			
TERMINAL NAME: TERMINAL MATRIX 1.2			
WIRE STRIP LENGTH 3.20-3.80 mm [1.26-.150 IN]		INSULATION DIAMETER RANGE Ø1.70-2.10 mm [.067-.083 IN]	
TERMINAL APPLICATION SPECIFICATION	BOSCH 1928 A00 47M-EN	-	-
TERMINALS APPLIED			
TE TERMINAL	BOSCH TERMINAL	TE TERMINAL	BOSCH TERMINAL
2113044-1	1928498674	2113044-3	1928498680
2113044-2	1928498677	2137409-1	1928498674

WIRE SIZE	CRIMP HEIGHT mm [INCH]	CRIMP HEIGHT REFERENCE SETTING
1.00mm2	1.13 +/- 0.03 [1.04 +/- .001]	6.6
0.75mm2	1.03 +/- 0.03 [1.04 +/- .001]	7.6

- 1 RECOMMENDED SPARE PARTS
- 2 REFER TO SUPPLIED INSTRUCTION SHEET FOR CLEANING, LUBRICATION AND STORAGE OF APPLICATOR.
- 3 APPLY PART NUMBER 2-23419-6 LOCTITE TO THREADS OF ITEM 242.
- 4 CRIMP HEIGHT REFERENCE SETTING WAS THE SETTING USED WHEN THE APPLICATOR WAS QUALIFIED AT THE FACTORY. ADJUSTMENT MAY BE NECESSARY WHEN RUNNING APPLICATOR IN THE FIELD.
- 5. UNLESS SPECIFIED OTHERWISE TORQUE VALUES SHALL BE USED PER DOCUMENT, 101-35000.
- 6 TERMINAL LUBRICANT IS RECOMMENDED.

***WARNING**
ON INSTALLATION, SET WIRE DISC TO CRIMP HEIGHT REFERENCE SETTING FOR LARGEST WIRE SIZE. CRIMP HEIGHT REFERENCE SETTINGS GREATER THAN THE VALUE SHOWN MAY CAUSE DAMAGE TO THE CRIMP TOOLING, REFER TO THE INSTRUCTION SHEET FOR PROPER SETUP AND ADJUSTMENTS.

PACIFIC VERSION
Shown on sheets 3 of 4 & 4 of 4
(Atlantic version shown on sheets 1 of 4 & 2 of 4)

LOC	DIST	REV	DATE	BY	APPV
A	66	-	-	-	-

REV	DATE	BY	APPV	DESCRIPTION	ITEM NO
-	2	2		2168083-1 SCR, SKT HD CAP, RoHS, M3 X 8.0	269
-	1	1		1633782-4 FENCE	267
-	1	1		2119082-5 CAM, SNAIL, INSULATION ADJUSTMENT	244
-	1	1		2079764-1 WASHER, WAVE SPRING, CREST-TO-CREST	243
-	1	1		2119083-1 RETAINER, INSULATION DIAL	242
-	1	1		7-18023-7 SCR, SKT HD CAP M3 X 4.0	241
-	-	1		2119580-1 MECHANICAL FEED ASSEMBLY	239
-	1	-		2844940-1 AIR FEED MODULE	238
-	REF	REF		994970-2 COUNTER, MAGNETIC	164
-	1	-		2119641-2 FEED CAM, AIR FEED	151
-	1	1		2168083-8 SCR, SKT HD CAP, RoHS, M4 X 16	144
-	4	4		2168083-9 SCR, SKT HD CAP, RoHS, M4 X 20	143
-	-	1		2119653-2 FEED CAM, POST FEED	142
-	1	1		1-1803583-0 APPLICATOR BASIC ASSEMBLY, SF	141
-	1	1		1803516-1 RAM ASSEMBLY, SF PACIFIC	140
-	1	1		2119955-1 ASSY, LUBRICATOR, SIDE FEED	113
-	1	1		2844908-1 SCREW, LOCKING	99
-	1	1		2844907-1 POST, LOCKING	98
-	1	1		455888-7 SPACER, CRIMPER	82
-	1	1		1803607-3 DOCUMENTATION PACKAGE	71
-	1	1		2119791-5 DEPRESSOR, WIRE	70
-	1	1		2119740-1 TAG, IDENTIFICATION	67
-	2	2		2168078-1 SCREW, DRIVE, RH, RoHS, 2 x .188	66
-	1	1		5-18022-5 SCR, HEX HD CAP, M4 X 6.0	59
-	1	1		1338685-1 PAWL, FEED	56
-	2	2		2-2168083-5 SCR, SKT HD CAP, RoHS, M4 X 14	53
-	1	1		1803382-1 HOLD DOWN, SPRING LOADED	50
-	1	2		18023-9 SCR, SKT HD CAP M4 X 6.0	49
-	-	1		2119652-1 FEED CAM, PRE FEED	48
-	1	1		1803602-1 SCR, BHSC, RoHS (M8 X 25)	41
-	1	1		2-1752356-0 SUPPORT, TERMINAL	34
-	2	2		2079383-5 SCR, BHSC, RoHS (M4 X 20)	33
-	2	2		2-2844962-6 SPACER, CYLINDRICAL, STRIP GUIDE	30
-	1	1		2844992-1 ASSEMBLY, STRIP GUIDE	29
-	1	1		455888-3 SPACER, CRIMPER	28
-	1	1		1320928-2 STRIP GUIDE	24
-	1	1		2168083-2 SCR, SKT HD CAP, RoHS, M4 X 8.0	21
-	2	2		1-18028-2 WASHER, FLAT, REG M4	20
-	1	1		2119533-1 STRIPPER, SIDE FEED	19
-	1	1		2119806-1 INSERT, SHEAR	13
-	1	1		3-22280-3 SPRING, COMPRESSION	12
-	1	1		1-356885-4 STOP, SHEAR	11
-	1	1		2119805-1 SHEAR HOLDER, FRONT	10
-	1	1		1803095-1 FLOATING SHEAR, FRONT	9
-	1	1		6-1633620-3 ANVIL, COMBINATION	8
-	1	1		4-240641-6 SPACER	7
-	-	-		-	6
-	1	1		2119757-4 DEPRESSOR, SHEAR	5
-	1	1		1-238011-9 BLOCK, CRIMPER SPACER	4
-	1	1		5-1803019-0 CRIMPER, INSULATION O	3
-	-	-		-	2
-	1	1		3-456404-2 CRIMPER, WIRE PREMIUM	1

DIMENSIONS:		TOLERANCES UNLESS OTHERWISE SPECIFIED:		DWG. STAKEM 25AUG2014		TE Connectivity	
mm		0 PLC ±		CHK G. BAILEY 25AUG2014		Harrisburg, PA 17105-3608	
		1 PLC ±		APPV T. ELBIN 25AUG2014		NAME	
		2 PLC ±		PRODUCT SPEC		Ocean Side Feed	
		3 PLC ±		APPLICATION SPEC		Applicator	
		4 PLC ±		SIZE CAGE CODE DRAWING NO		RESTRICTED TO	
		ANGLES		A1 00779 C=2266461		-	
		FINISH		WEIGHT		SCALE 1:2 SHEET 3 OF 4 REV G	
MATERIAL				Customer Accessible Production Drawing		Customer Accessible Production Drawing	

LOC		DIST		REVISIONS			
A	66	P	LTM	DESCRIPTION	DATE	OWN	APVD
		-		SEE SHEET 1			

FEED TYPE MECHANICAL

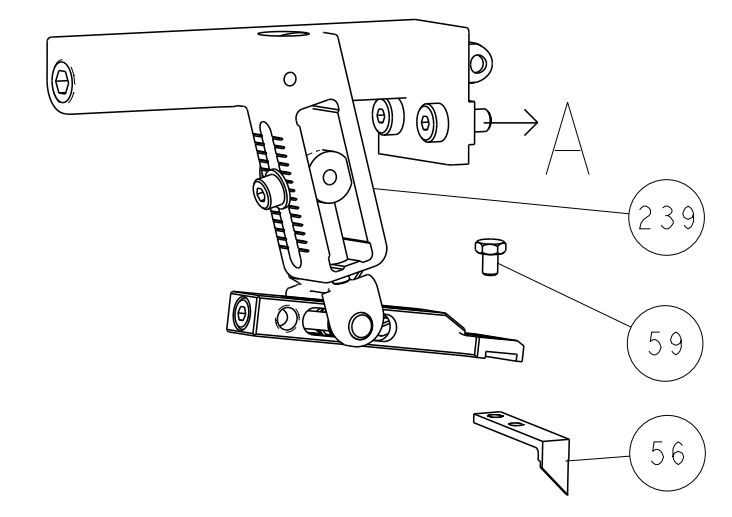

PNEUMATIC

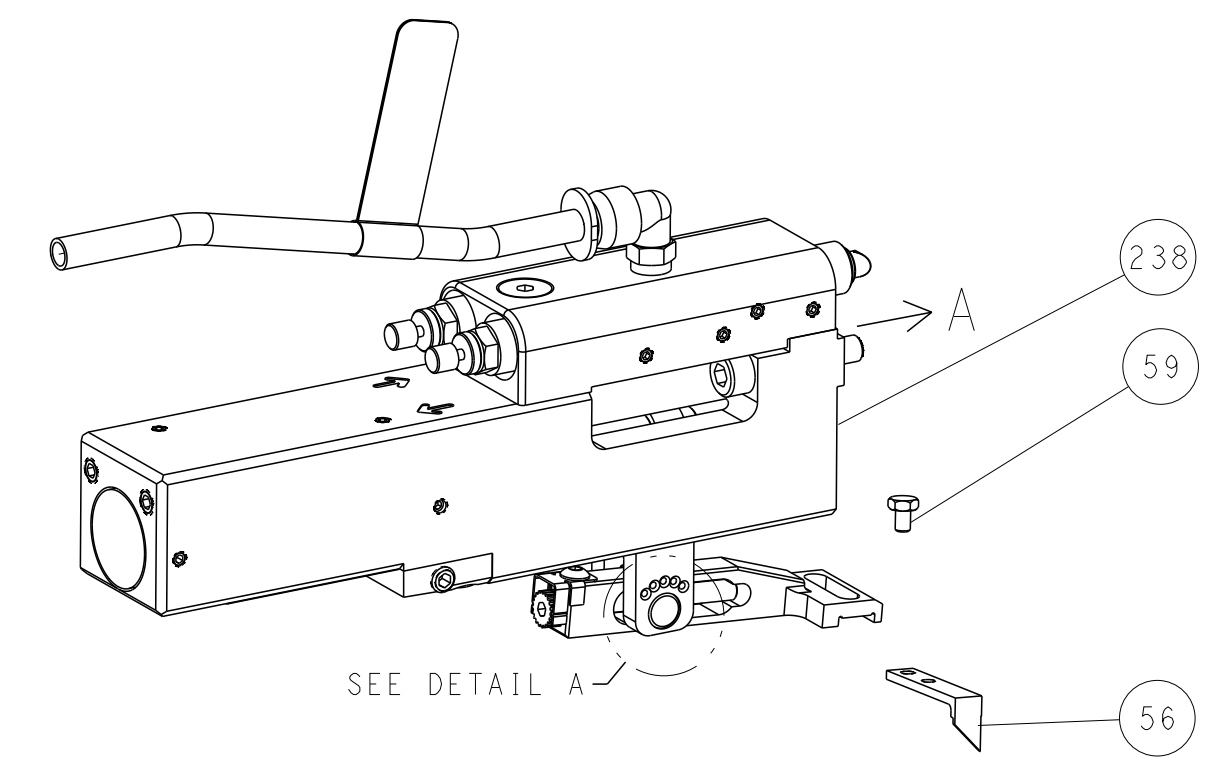

FEED SPRING SETTING POSITION (SHOWN FROM REAR SIDE)

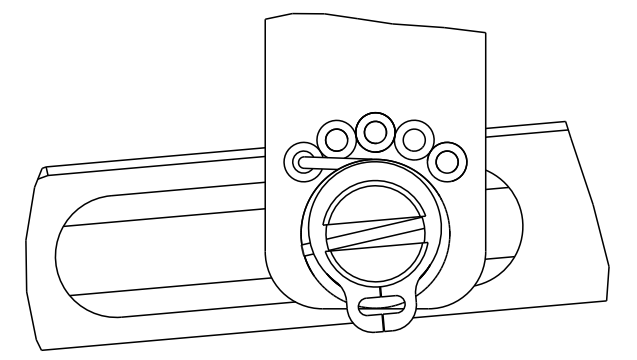

DETAIL A

CAM POSITIONS

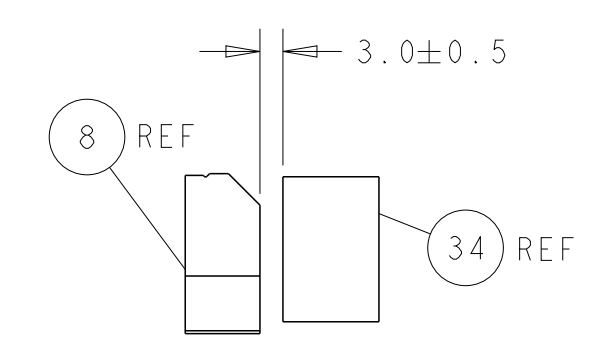
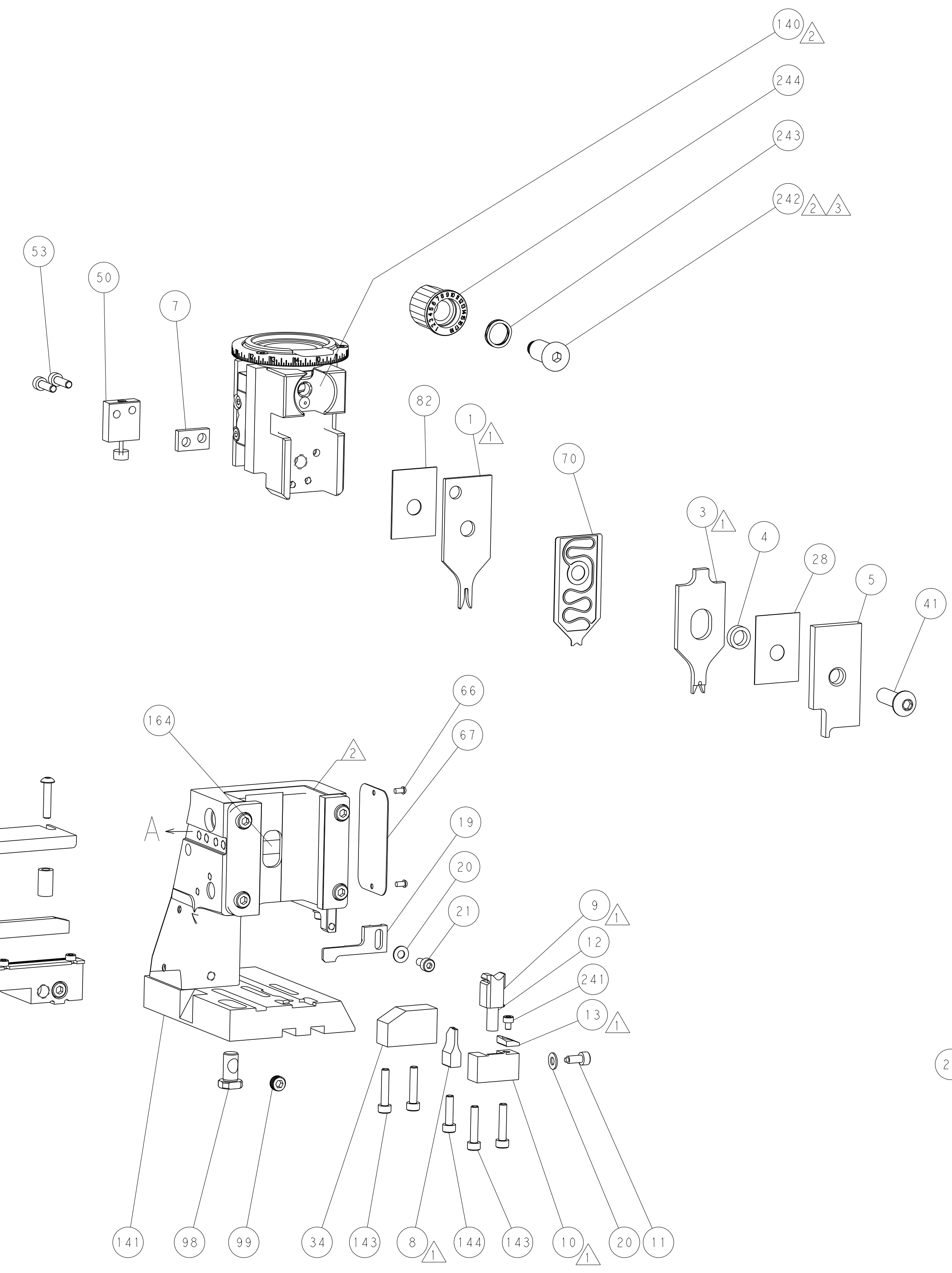
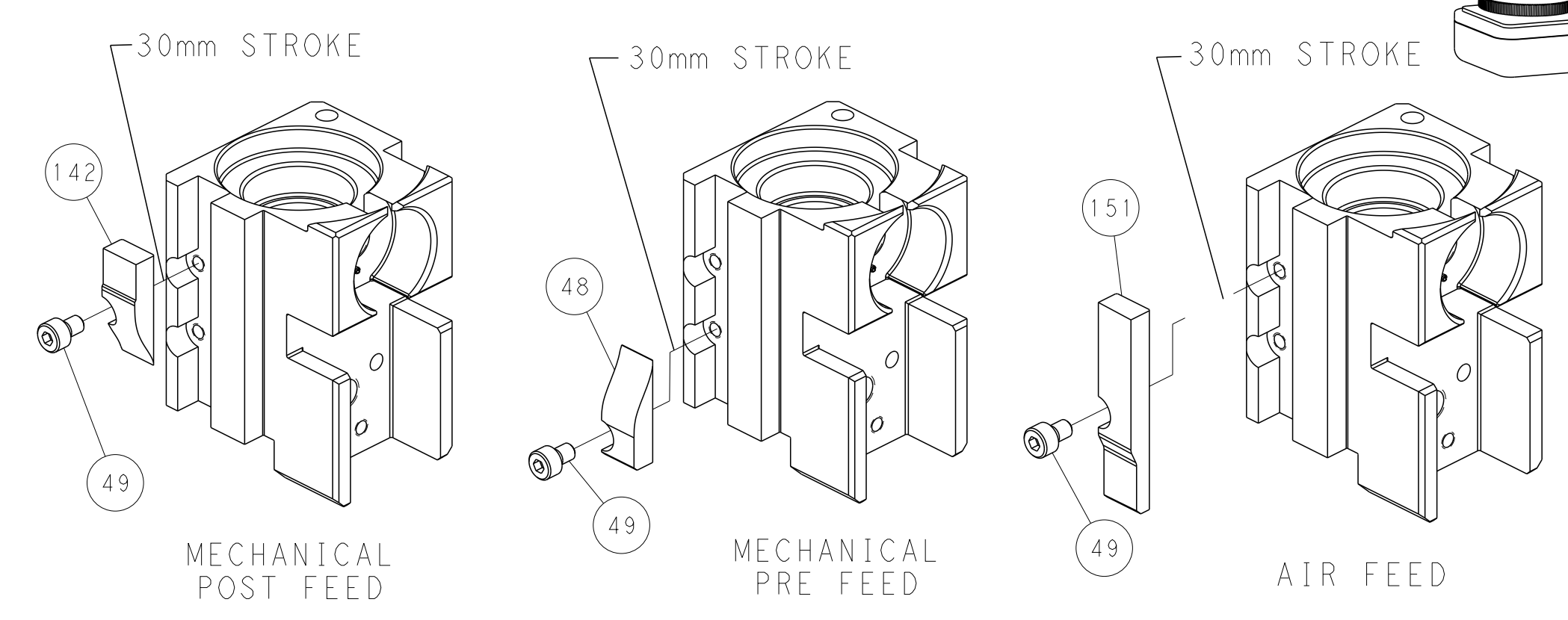

TERMINAL SUPPORT LOCATION

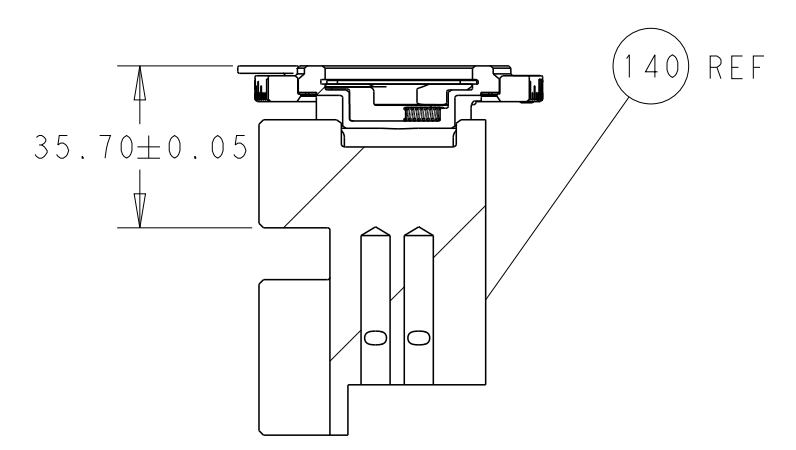

RAM SET-UP

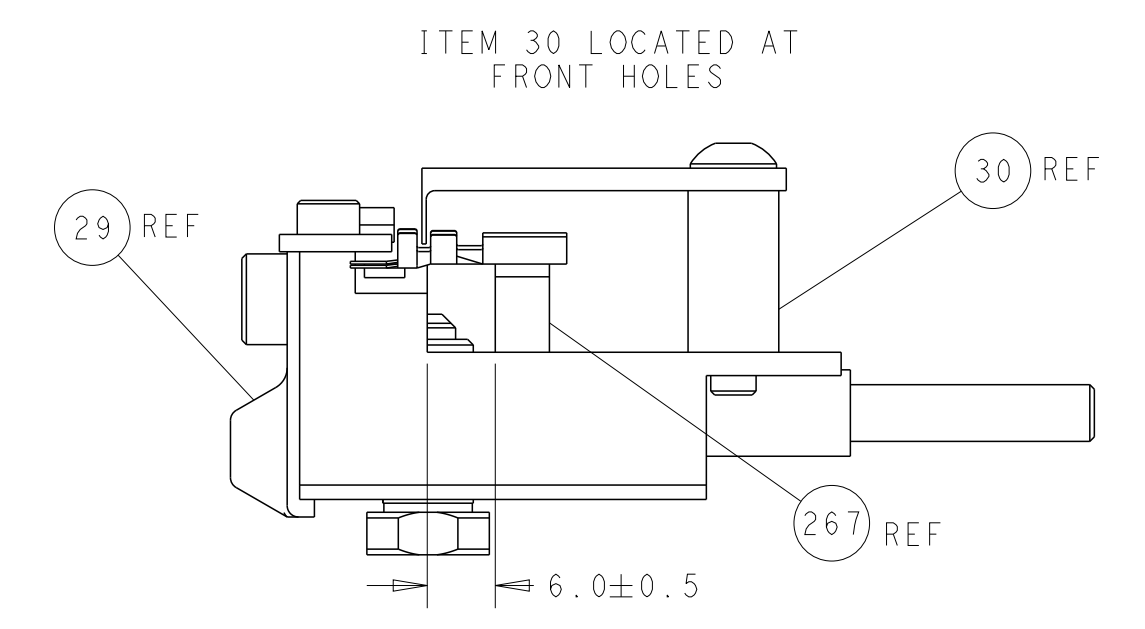

FEED TRACK POSITION GUIDE BY INSULATION BARREL

PACIFIC VERSION
 Shown on sheets 3 of 4 & 4 of 4
 (Atlantic version shown on sheets 1 of 4 & 2 of 4)

DIMENSIONS:		TOLERANCES UNLESS OTHERWISE SPECIFIED:		DWN: R. STAKEM 25AUG2014		TE Connectivity	
mm	0 PLC ±	1 PLC ±	2 PLC ±	3 PLC ±	4 PLC ±	5 PLC ±	Harrisburg, PA 17105-3608
MATERIAL:	FINISH:	WEIGHT:	SCALE:	APVD: T. ELBIN 25AUG2014	NAME:	SIZE:	CAGE CODE:
			1:2	PRODUCT SPEC:	Ocean Side Feed	00779	2266461
				APPLICATION SPEC:	Applicator		
				RESTRICTED TO:			
				Customer Accessible Production Drawing			