

The S-5841 Series is a temperature switch IC (thermostat IC) which detects the temperature with a temperature accuracy of  $\pm 2.5^{\circ}\text{C}$ . The output inverts when temperature reaches the detection temperature. The S-5841 Series restores the output voltage when the temperature drops to the level of release temperature.

The S-5841 Series operates at the lower power supply voltage of 2.2 V and its current consumption is 10  $\mu\text{A}$  typ. due to CMOS configuration.

A temperature sensor with the negative temperature coefficient, a reference voltage generation circuit, a comparator and a delay circuit are integrated on one chip, and enclosed into the packages SOT-23-5 and SNT-6A.

## ■ Features

- Detection temperature:  $T_{\text{DET}} = +40^{\circ}\text{C}$  to  $+100^{\circ}\text{C}$ ,  $+1^{\circ}\text{C}$  step, detection accuracy:  $\pm 2.5^{\circ}\text{C}$
- Low voltage operation:  $V_{\text{DD}} = 2.2\text{ V min.}$   
(Detection temperature =  $+55^{\circ}\text{C}$  to  $+100^{\circ}\text{C}$ ,  $T_{\text{a}} = -40^{\circ}\text{C}$  to  $+100^{\circ}\text{C}$ )
- Low current consumption:  $I_{\text{DD}} = 10\ \mu\text{A typ.}$  ( $T_{\text{a}} = +25^{\circ}\text{C}$ )
- Hysteresis temperature can be switched in  $0^{\circ}\text{C}$ ,  $2^{\circ}\text{C}$ ,  $4^{\circ}\text{C}$  and  $10^{\circ}\text{C}$ .
- Selectable output logic in active "H" or "L"
- Selectable output form in CMOS or Nch open drain
- Operation temperature range:  $T_{\text{a}} = -40^{\circ}\text{C}$  to  $+125^{\circ}\text{C}$
- Lead-free, Sn 100%, halogen-free<sup>\*1</sup>

\*1. Refer to "■ Product Name Structure" for details.

## ■ Applications

- Fan control
- Air conditioning system
- Various electronic devices

## ■ Packages

- SOT-23-5
- SNT-6A

■ Block Diagrams

1. CMOS output product

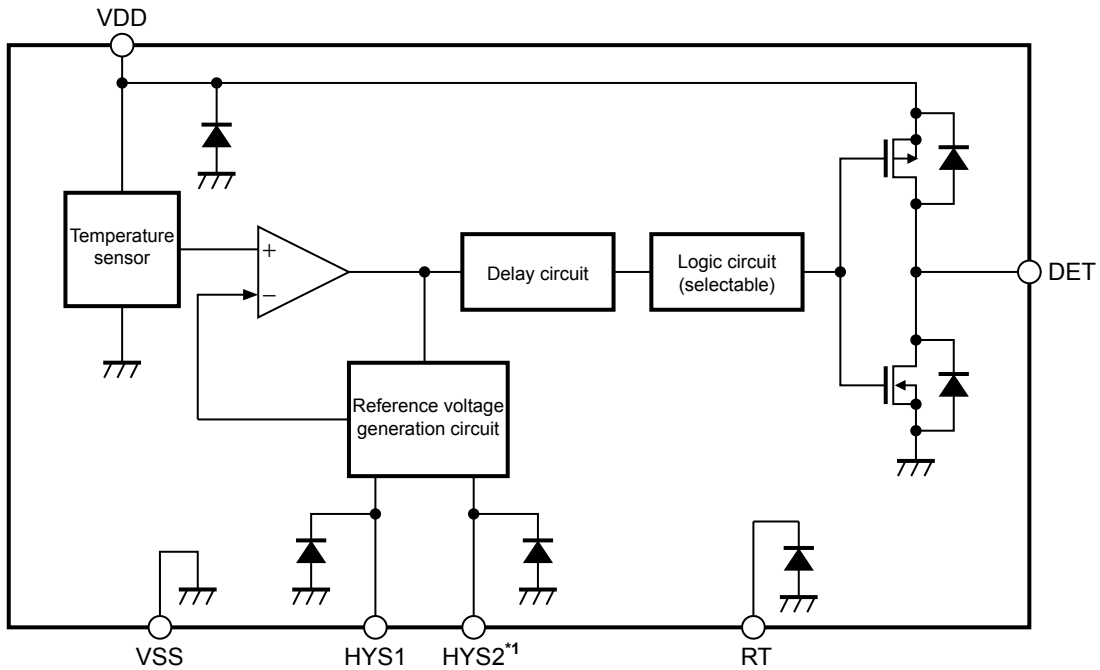

\*1. The HYS2 pin is not equipped for SOT-23-5.

Figure 1

2. Nch open drain output product

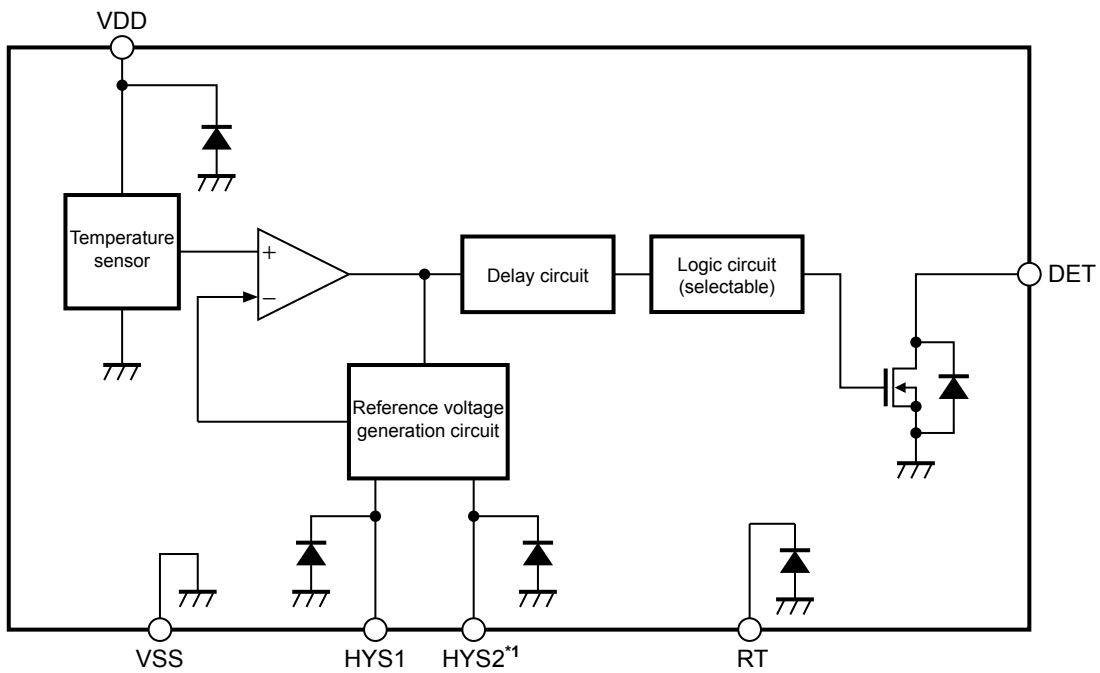

\*1. The HYS2 pin is not equipped for SOT-23-5.

Figure 2

■ Product Name Structure

Users are able to select the option for hysteresis temperature, detection temperature, output form and logic, package for the S-5841 Series.

1. Product name

1.1 SOT-23-5

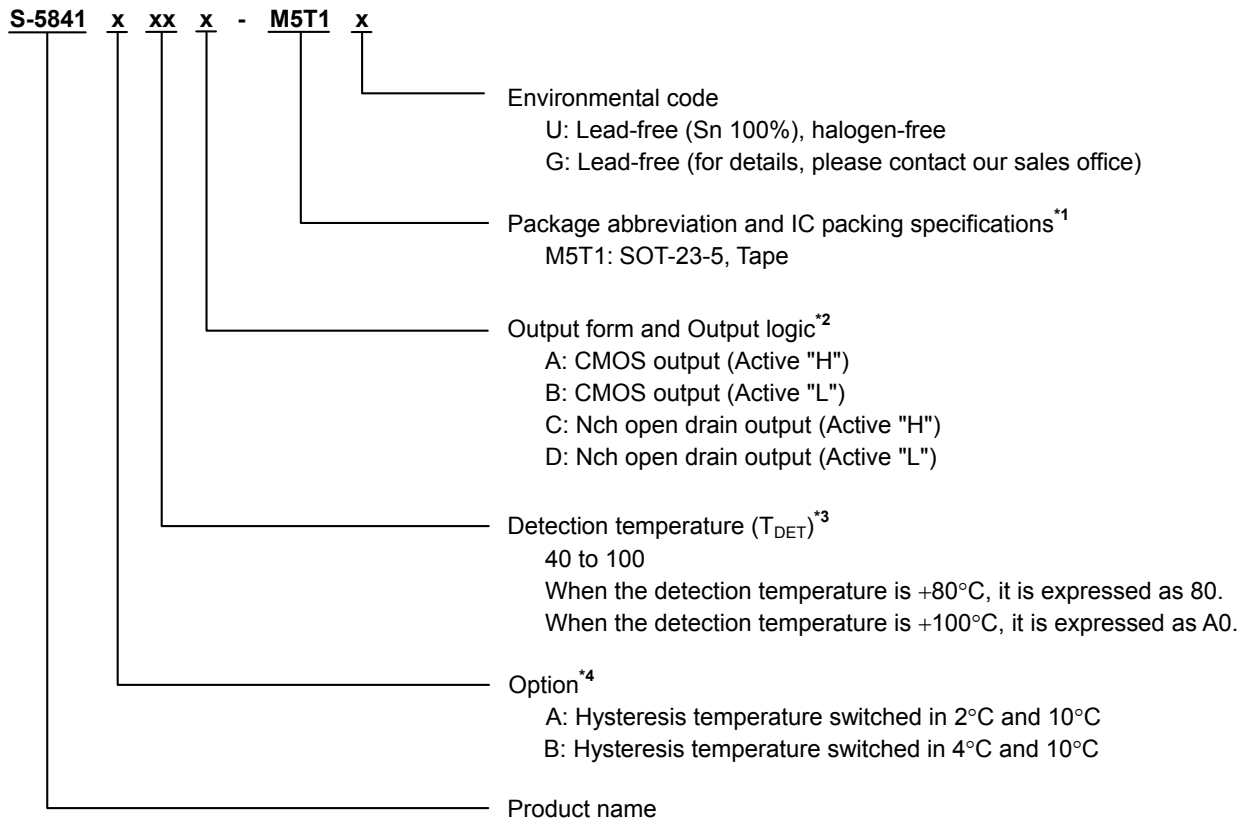

- \*1. Refer to the tape drawing.
- \*2. The DET pin output can be selected the output logic in active "H" or "L".  
The DET pin output can be selected the output form in CMOS or Nch open drain.
- \*3. The detection temperature (T<sub>DET</sub>) can be set in the range of +40°C to +100°C at 1°C step.
- \*4. The hysteresis temperature is set by the HYS1 pin. By option, the hysteresis temperature of the product is selectable in 2°C and 10°C / 4°C and 10°C.

**1.2 SNT-6A**

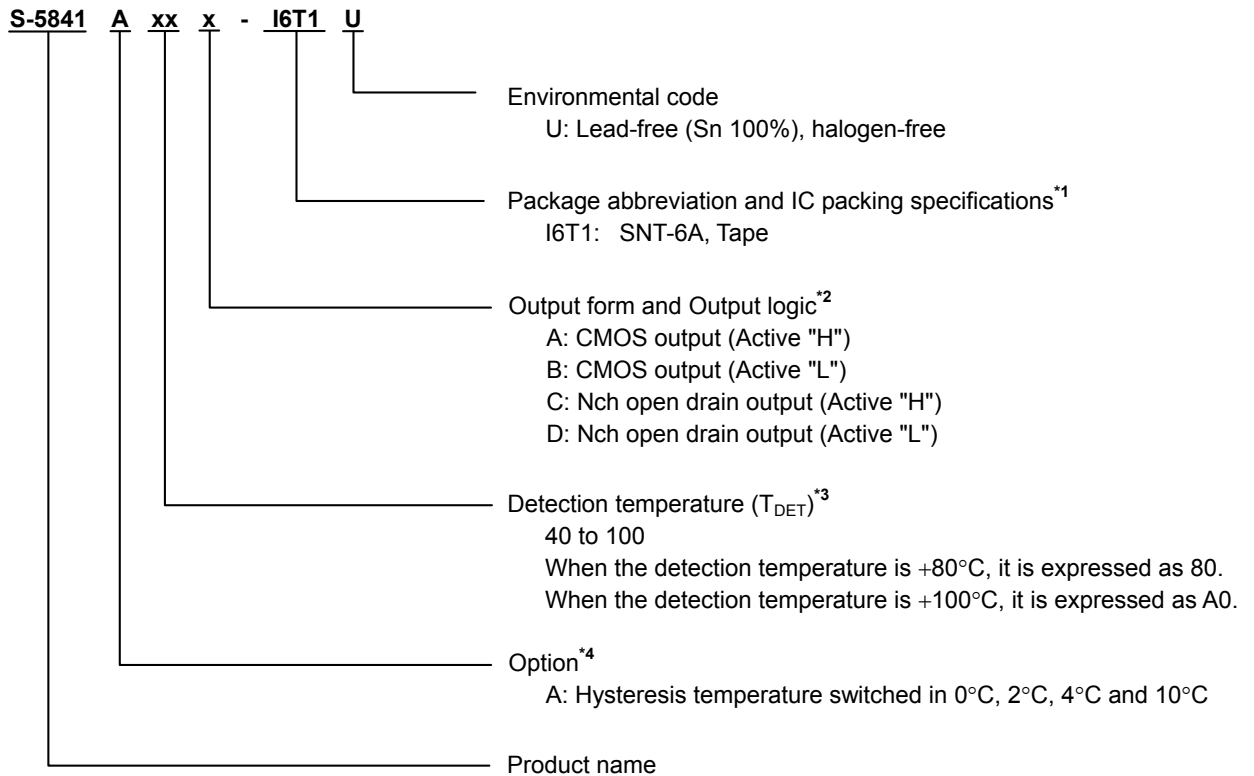

- \*1. Refer to the tape drawing.
- \*2. The DET pin output can be selected the output logic in active "H" or "L".  
The DET pin output can be selected the output form in CMOS or Nch open drain.
- \*3. The detection temperature (T<sub>DET</sub>) can be set in the range of +40°C to +100°C at 1°C step.
- \*4. The hysteresis temperature can be switched in 0°C, 2°C, 4°C, 10°C, and is set by the HYS1 pin and the HYS2 pin.

**2. Packages**

**Table 1 Package Drawing Codes**

Package Name	Dimension	Tape	Reel	Land
SOT-23-5	MP005-A-P-SD	MP005-A-C-SD	MP005-A-R-SD	—
SNT-6A	PG006-A-P-SD	PG006-A-C-SD	PG006-A-R-SD	PG006-A-L-SD

3. Product name list

3.1 SOT-23-5

Table 2

Product Name	Detection Temperature (T <sub>DET</sub> )	DET Pin Output Form	DET Pin Output Logic	Hysteresis Temperature (T <sub>HYS</sub> )
S-5841A55D-M5T1x	+55°C	Nch open drain	Active "L"	2°C, 10°C
S-5841A65D-M5T1x	+65°C	Nch open drain	Active "L"	2°C, 10°C
S-5841A75D-M5T1x	+75°C	Nch open drain	Active "L"	2°C, 10°C
S-5841A85D-M5T1x	+85°C	Nch open drain	Active "L"	2°C, 10°C
S-5841A95D-M5T1x	+95°C	Nch open drain	Active "L"	2°C, 10°C

**Remark 1.** Please contact our sales office for products other than those specified above.

2. x: G or U

3. Please select products of environmental code = U for Sn 100%, halogen-free products.

3.2 SNT-6A

Table 3

Product Name	Detection Temperature (T <sub>DET</sub> )	DET Pin Output Form	DET Pin Output Logic	Hysteresis Temperature (T <sub>HYS</sub> )
S-5841A70A-I6T1U	+70°C	CMOS	Active "H"	0°C, 2°C, 4°C, 10°C
S-5841A80A-I6T1U	+80°C	CMOS	Active "H"	0°C, 2°C, 4°C, 10°C
S-5841A90A-I6T1U	+90°C	CMOS	Active "H"	0°C, 2°C, 4°C, 10°C
S-5841A50D-I6T1U	+50°C	Nch open drain	Active "L"	0°C, 2°C, 4°C, 10°C

**Remark** Please contact our sales office for products other than those specified above.

■ Pin Configurations

1. SOT-23-5

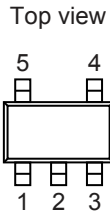

Figure 3

Table 4

Pin No.	Symbol	Description
1	HYS1 <sup>*1</sup>	Hysteresis pin 1
2	VSS	GND pin
3	RT <sup>*2</sup>	Test pin
4	VDD	Power supply pin
5	DET	Output pin

\*1. Fix the HYS1 pin as VDD pin or VSS pin in use.

\*2. Set the RT pin open in use.

2. SNT-6A

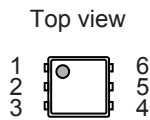

Figure 4

Table 5

Pin No.	Symbol	Description
1	RT <sup>*1</sup>	Test pin
2	VSS	GND pin
3	HYS1 <sup>*2</sup>	Hysteresis pin 1
4	DET	Output pin
5	HYS2 <sup>*2</sup>	Hysteresis pin 2
6	VDD	Power supply pin

\*1. Set the RT pin open in use.

\*2. Fix the HYS1 pin and the HYS2 pin as VDD pin or VSS pin in use.

## ■ Absolute Maximum Ratings

Table 6

(Ta = +25°C unless otherwise specified)

Item	Symbol	Absolute Maximum Rating	Unit
Power supply voltage (V <sub>SS</sub> = 0 V)	V <sub>DD</sub>	V <sub>SS</sub> + 12	V
Pin voltage	V <sub>RT</sub> , V <sub>HYS1</sub> , V <sub>HYS2</sub>	V <sub>SS</sub> - 0.3 to V <sub>DD</sub> + 0.3	V
Output voltage	CMOS output product	V <sub>SS</sub> - 0.3 to V <sub>DD</sub> + 0.3	V
	Nch open drain product	V <sub>SS</sub> - 0.3 to V <sub>SS</sub> + 12.0	V
Power dissipation	SOT-23-5	600 <sup>*1</sup>	mW
	SNT-6A	400 <sup>*1</sup>	mW
Operating ambient temperature	T <sub>opr</sub>	-40 to +125	°C
Storage temperature	T <sub>stg</sub>	-55 to +150	°C

\*1. When mounted on board

[Mounted board]

- (1) Board size : 114.3 mm × 76.2 mm × t1.6 mm
- (2) Board name : JEDEC STANDARD51-7

**Caution** The absolute maximum ratings are rated values exceeding which the product could suffer physical damage. These values must therefore not be exceeded under any conditions.

■ DC Electrical Characteristics

1. CMOS output product

1.1 SOT-23-5

Table 7

(Ta = +25°C, unless otherwise specified)

Item	Symbol	Condition		Min.	Typ.	Max.	Unit	Test circuit
Power supply voltage*1	V <sub>DD</sub>	T <sub>DET</sub> = +55°C to +100°C		2.2	–	10.0	V	1
		T <sub>DET</sub> = +40°C to +54°C		2.6	–	10.0	V	1
Detection temperature	+T <sub>D</sub>	–		T <sub>DET</sub> – 2.5	T <sub>DET</sub>	T <sub>DET</sub> + 2.5	°C	1
Hysteresis of detection temperature*2	T <sub>HYS</sub>	Hysteresis option	HYS1	–	–	–	–	–
		A	"H"	–	2	–	°C	1
			"L"	–	10	–	°C	1
		B	"H"	–	4	–	°C	1
"L"	–		10	–	°C	1		
Output current	I <sub>DETH</sub>	V <sub>DD</sub> = 3.0 V, apply to DET pin	V <sub>DET</sub> = 2.2 V	2	9.4	–	mA	2
	I <sub>DETL</sub>		V <sub>DET</sub> = 0.4 V	0.5	2.3	–	mA	2
Current consumption during operation	I <sub>DD</sub>	V <sub>DD</sub> = 3.0 V		–	10	20	μA	1
HYS1 pin input voltage "H"	V <sub>IH1</sub>	–		0.8 × V <sub>DD</sub>	–	–	V	3
HYS1 pin input voltage "L"	V <sub>IL1</sub>	–		–	–	0.2 × V <sub>DD</sub>	V	3
HYS1 pin input current "H"	I <sub>IH1</sub>	V <sub>DD</sub> = 3.0 V, V <sub>HYS1</sub> = 3.0 V		–0.1	–	0.1	μA	3
HYS1 pin input current "L"	I <sub>IL1</sub>	V <sub>DD</sub> = 3.0 V, V <sub>HYS1</sub> = 0 V		–0.1	–	0.1	μA	3

\*1. The minimum operation voltages are as follows under the operation ambient temperature over +100°C.  
V<sub>DD</sub> = 2.3 V min. (Detection temperature = +55°C to +100°C)  
V<sub>DD</sub> = 2.7 V min. (Detection temperature = +40°C to +54°C)

\*2. The hysteresis temperature can be set by the HYS1 pin.  
These two types are selectable by option.  
Hysteresis option A: 2°C of hysteresis temperature during HYS1 = "H",  
10°C of hysteresis temperature during HYS1 = "L"  
Hysteresis option B: 4°C of hysteresis temperature during HYS1 = "H",  
10°C of hysteresis temperature during HYS1 = "L"

[Fahrenheit ⇔ Celsius Conversion equation]

$$^{\circ}\text{C} = (^{\circ}\text{F} - 32) \times 5 / 9$$

$$^{\circ}\text{F} = 32 + ^{\circ}\text{C} \times 9 / 5$$



**1.2 SNT-6A**

**Table 8**

(Ta = +25°C, unless otherwise specified)

Item	Symbol	Condition	Min.	Typ.	Max.	Unit	Test circuit	
Power supply voltage*1	V <sub>DD</sub>	T <sub>DET</sub> = +55°C to +100°C	2.2	–	10.0	V	1	
		T <sub>DET</sub> = +40°C to +54°C	2.6	–	10.0	V	1	
Detection temperature	+T <sub>D</sub>	–	T <sub>DET</sub> – 2.5	T <sub>DET</sub>	T <sub>DET</sub> + 2.5	°C	1	
Hysteresis of detection temperature*2	T <sub>HYS</sub>	HYS1	HYS2	–	–	–	–	
		"H"	"H"	–	2	–	°C	
		"H"	"L"	–	4	–	°C	
		"L"	"H"	–	10	–	°C	
		"L"	"L"	–	0	–	°C	
Output current	I <sub>DETH</sub>	V <sub>DD</sub> = 3.0 V, apply to DET pin	V <sub>DET</sub> = 2.2 V	2	9.4	–	mA	2
	I <sub>DETL</sub>		V <sub>DET</sub> = 0.4 V	0.5	2.3	–	mA	2
Current consumption during operation	I <sub>DD</sub>	V <sub>DD</sub> = 3.0 V	–	10	20	μA	1	
HYS1 pin input voltage "H"	V <sub>IH1</sub>	–	0.8 × V <sub>DD</sub>	–	–	V	3	
HYS1 pin input voltage "L"	V <sub>IL1</sub>	–	–	–	0.2 × V <sub>DD</sub>	V	3	
HYS1 pin input current "H"	I <sub>IH1</sub>	V <sub>DD</sub> = 3.0 V, V <sub>HYS1</sub> = 3.0 V	–0.1	–	0.1	μA	3	
HYS1 pin input current "L"	I <sub>IL1</sub>	V <sub>DD</sub> = 3.0 V, V <sub>HYS1</sub> = 0 V	–0.1	–	0.1	μA	3	
HYS2 pin input voltage "H"	V <sub>IH2</sub>	–	0.8 × V <sub>DD</sub>	–	–	V	3	
HYS2 pin input voltage "L"	V <sub>IL2</sub>	–	–	–	0.2 × V <sub>DD</sub>	V	3	
HYS2 pin input current "H"	I <sub>IH2</sub>	V <sub>DD</sub> = 3.0 V, V <sub>HYS2</sub> = 3.0 V	–0.1	–	0.1	μA	3	
HYS2 pin input current "L"	I <sub>IL2</sub>	V <sub>DD</sub> = 3.0 V, V <sub>HYS2</sub> = 0 V	–0.1	–	0.1	μA	3	

\*1. The minimum operation voltages are as follows under the operation ambient temperature over +100°C.

V<sub>DD</sub> = 2.3 V min. (Detection temperature = +55°C to +100°C)

V<sub>DD</sub> = 2.7 V min. (Detection temperature = +40°C to +54°C)

\*2. The hysteresis temperature can be switched in 0°C, 2°C, 4°C, 10°C, and is set by the HYS1 pin and HYS2 pin.

**[Fahrenheit ↔ Celsius Conversion equation]**

$$°C = (°F - 32) \times 5 / 9$$

$$°F = 32 + °C \times 9 / 5$$

**2. Nch open drain output**

**2.1 SOT-23-5**

**Table 9**

(Ta = +25°C, unless otherwise specified)

Item	Symbol	Condition	Min.	Typ.	Max.	Unit	Test circuit	
Power supply voltage*1	V <sub>DD</sub>	T <sub>DET</sub> = +55°C to +100°C	2.2	–	10.0	V	1	
		T <sub>DET</sub> = +40°C to +54°C	2.6	–	10.0	V	1	
Detection temperature	+T <sub>D</sub>	–	T <sub>DET</sub> – 2.5	T <sub>DET</sub>	T <sub>DET</sub> + 2.5	°C	1	
Hysteresis of detection temperature*2	T <sub>HYS</sub>	Hysteresis option	HYS1		–	–	–	
		A	"H"	–	2	–	°C	1
			"L"	–	10	–	°C	1
		B	"H"	–	4	–	°C	1
"L"	–		10	–	°C	1		
Output current	I <sub>DETL</sub>	V <sub>DET</sub> = 0.4 V, V <sub>DD</sub> = 3.0 V	0.5	2.3	–	mA	2	
Leakage current	I <sub>LEAK</sub>	V <sub>DET</sub> = 10.0 V, V <sub>DD</sub> = 3.0 V	–	–	100	nA	2	
Current consumption during operation	I <sub>DD</sub>	V <sub>DD</sub> = 3.0 V	–	10	20	μA	1	
HYS1 pin input voltage "H"	V <sub>IH1</sub>	–	0.8 × V <sub>DD</sub>	–	–	V	3	
HYS1 pin input voltage "L"	V <sub>IL1</sub>	–	–	–	0.2 × V <sub>DD</sub>	V	3	
HYS1 pin input current "H"	I <sub>IH1</sub>	V <sub>DD</sub> = 3.0 V, V <sub>HYS1</sub> = 3.0 V	–0.1	–	0.1	μA	3	
HYS1 pin input current "L"	I <sub>IL1</sub>	V <sub>DD</sub> = 3.0 V, V <sub>HYS1</sub> = 0 V	–0.1	–	0.1	μA	3	

\*1. The minimum operation voltages are as follows under the operation ambient temperature over +100°C.

V<sub>DD</sub> = 2.3 V min. (Detection temperature = +55°C to +100°C)

V<sub>DD</sub> = 2.7 V min. (Detection temperature = +40°C to +54°C)

\*2. The hysteresis temperature can be set by the HYS1 pin.

These two types are selectable by option.

Hysteresis option A: 2°C of hysteresis temperature during HYS1 = "H",  
 10°C of hysteresis temperature during HYS1 = "L"

Hysteresis option B: 4°C of hysteresis temperature during HYS1 = "H",  
 10°C of hysteresis temperature during HYS1 = "L"

**[Fahrenheit ↔ Celsius Conversion equation]**

$$°C = (°F - 32) \times 5 / 9$$

$$°F = 32 + °C \times 9 / 5$$

**2.2 SNT-6A**

**Table 10**

(Ta = +25°C, unless otherwise specified)

Item	Symbol	Condition	Min.	Typ.	Max.	Unit	Test circuit
Power supply voltage*1	V <sub>DD</sub>	T <sub>DET</sub> = +55°C to +100°C	2.2	–	10.0	V	1
		T <sub>DET</sub> = +40°C to +54°C	2.6	–	10.0	V	1
Detection temperature	+T <sub>D</sub>	–	T <sub>DET</sub> – 2.5	T <sub>DET</sub>	T <sub>DET</sub> + 2.5	°C	1
Hysteresis of detection temperature*2	T <sub>HYS</sub>	HYS1	HYS2	–	–	–	–
		"H"	"H"	–	2	–	°C
		"H"	"L"	–	4	–	°C
		"L"	"H"	–	10	–	°C
		"L"	"L"	–	0	–	°C
Output current	I <sub>DETL</sub>	V <sub>DET</sub> = 0.4 V, V <sub>DD</sub> = 3.0 V	0.5	2.3	–	mA	2
Leakage current	I <sub>LEAK</sub>	V <sub>DET</sub> = 10.0 V, V <sub>DD</sub> = 3.0 V	–	–	100	nA	2
Current consumption during operation	I <sub>DD</sub>	V <sub>DD</sub> = 3.0 V	–	10	20	μA	1
HYS1 pin input voltage "H"	V <sub>IH1</sub>	–	0.8 × V <sub>DD</sub>	–	–	V	3
HYS1 pin input voltage "L"	V <sub>IL1</sub>	–	–	–	0.2 × V <sub>DD</sub>	V	3
HYS1 pin input current "H"	I <sub>IH1</sub>	V <sub>DD</sub> = 3.0 V, V <sub>HYS1</sub> = 3.0 V	–0.1	–	0.1	μA	3
HYS1 pin input current "L"	I <sub>IL1</sub>	V <sub>DD</sub> = 3.0 V, V <sub>HYS1</sub> = 0 V	–0.1	–	0.1	μA	3
HYS2 pin input voltage "H"	V <sub>IH2</sub>	–	0.8 × V <sub>DD</sub>	–	–	V	3
HYS2 pin input voltage "L"	V <sub>IL2</sub>	–	–	–	0.2 × V <sub>DD</sub>	V	3
HYS2 pin input current "H"	I <sub>IH2</sub>	V <sub>DD</sub> = 3.0 V, V <sub>HYS2</sub> = 3.0 V	–0.1	–	0.1	μA	3
HYS2 pin input current "L"	I <sub>IL2</sub>	V <sub>DD</sub> = 3.0 V, V <sub>HYS2</sub> = 0 V	–0.1	–	0.1	μA	3

\*1. The minimum operation voltages are as follows under the operation ambient temperature over +100°C.

V<sub>DD</sub> = 2.3 V min. (Detection temperature = +55°C to +100°C)

V<sub>DD</sub> = 2.7 V min. (Detection temperature = +40°C to +54°C)

\*2. The hysteresis temperature can be switched in 0°C, 2°C, 4°C, 10°C, and is set by the HYS1 pin and HYS2 pin.

**[Fahrenheit ↔ Celsius Conversion equation]**

°C = (°F – 32) × 5 / 9

°F = 32 + °C × 9 / 5

**■ AC Electrical Characteristics**

**Table 11**

Item	Symbol	Condition	Min.	Typ.	Max.	Unit	Test circuit
Noise suppression time	t <sub>delay</sub>	V <sub>DD</sub> = 3.0 V, Ta = detection temperature	–	380	–	μs	–

■ Test Circuits

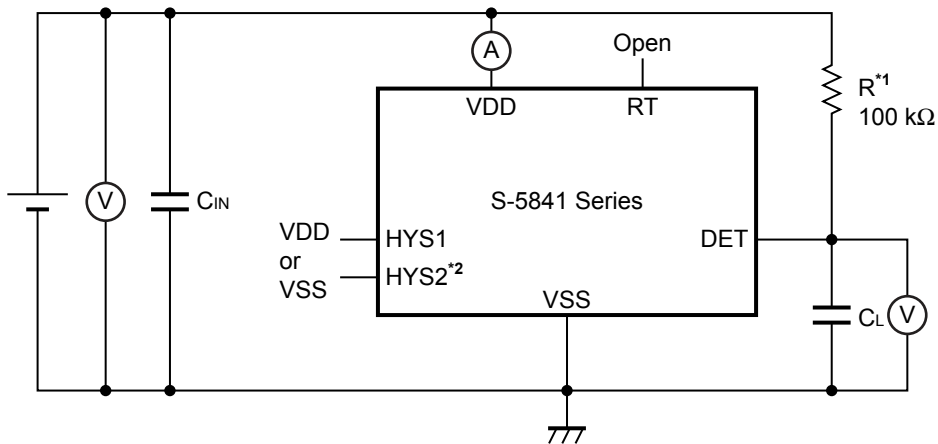

- \*1. Resistor (R) is unnecessary for the CMOS output product.
- \*2. The HYS2 pin is not equipped for SOT-23-5.

Figure 5 Test Circuit 1

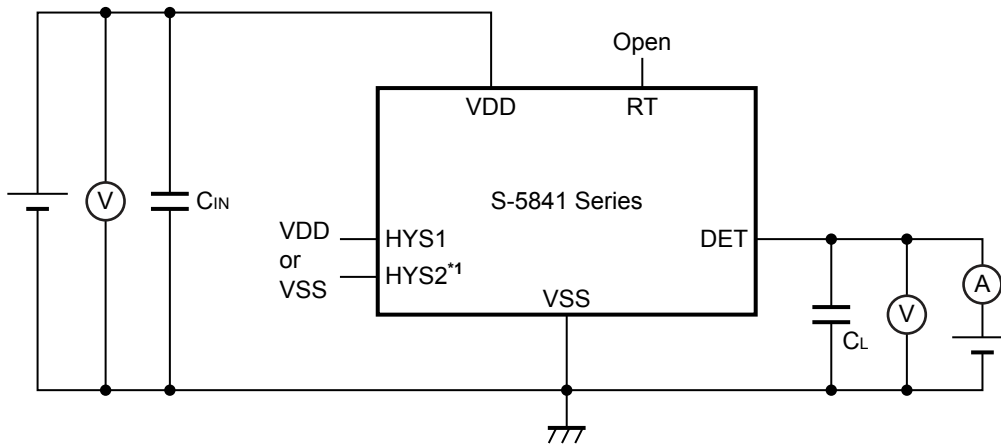

- \*1. The HYS2 pin is not equipped for SOT-23-5.

Figure 6 Test Circuit 2

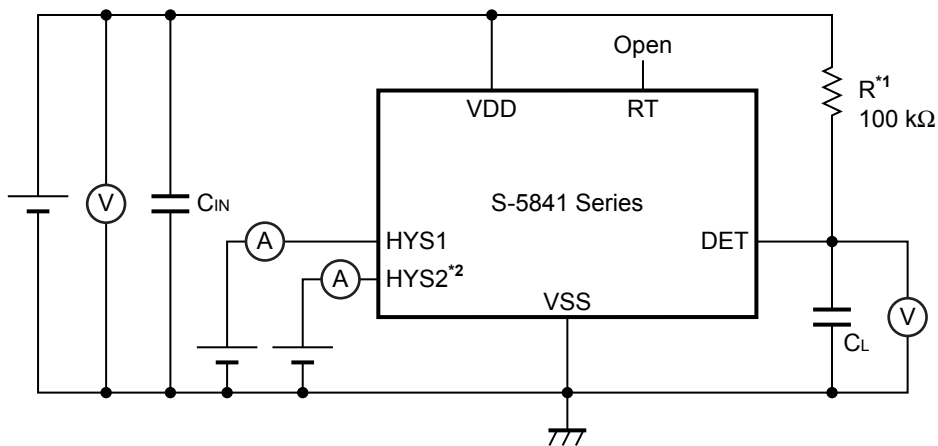

- \*1. Resistor (R) is unnecessary for the CMOS output product.
- \*2. The HYS2 pin is not equipped for SOT-23-5.

Figure 7 Test Circuit 3

■ Operation

1. Basic operation

The S-5841 Series is a temperature switch IC (thermostat IC) which detects a certain temperature and sends a signal to an external device. Various combinations of the parameters such as the detection temperature, output form and output logic can be selected.

Following is about the operation when the DET pin output logic is active "H".

After applying the power supply, the S-5841 Series starts to detect the temperature. If it is lower than the detection temperature ( $+T_D$ ), the DET pin output keeps "L". The temperature rises and exceeds the detection temperature, the DET pin is set to "H".

After the detection, the temperature drops and reaches the release temperature ( $+T_D - T_{HYS}$ ), the DET pin returns to "L".

Figure 8 is the timing chart.

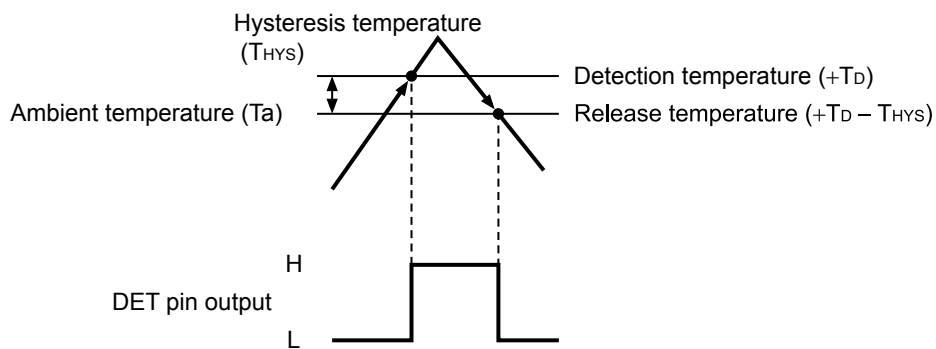

Figure 8 Operation when DET Pin Output Logic is Active "H"

2. Hysteresis setting

2.1 SOT-23-5

The hysteresis temperature can be set by the HYS1 pin. By option, the hysteresis temperature of the product is selectable in 2°C and 10°C / 4°C and 10°C.

Table 12 Hysteresis Option A

Setting Pin	Hysteresis Temperature
HYS1	
"H"	2°C
"L"	10°C

Table 13 Hysteresis Option B

Setting Pin	Hysteresis Temperature
HYS1	
"H"	4°C
"L"	10°C

## 2.2 SNT-6A

The hysteresis temperature can be switched in 0°C, 2°C, 4°C, 10°C, and is set by the HYS1 pin and HYS2 pin.

**Table 14 Hysteresis Option A**

Setting Pin		Hysteresis Temperature
HYS1	HYS2	
"H"	"H"	2°C
"H"	"L"	4°C
"L"	"H"	10°C
"L"	"L"	0°C

## 3. Delay circuit

The S-5841 Series sets the noise suppression time ( $t_{\text{delay}}$ ) via the delay circuit. By this, the S-5841 Series prevents false detection operations of the DET pin output.

The followings are about the operation when the DET pin output logic is active "H".

### 3.1 The temperature is the detection temperature or less

The output from a comparator is "H", and the DET pin is "L". Due to noise or others, the output from a comparator is inverted to "L" once; however, the DET pin keeps "L" if this status is  $t_{\text{delay}}$  or shorter.

### 3.2 The temperature exceeds the detection temperature

The output from a comparator gets "L". And the DET pin gets "H" after the period has passed  $t_{\text{delay}}$  or longer.

■ Standard Circuit

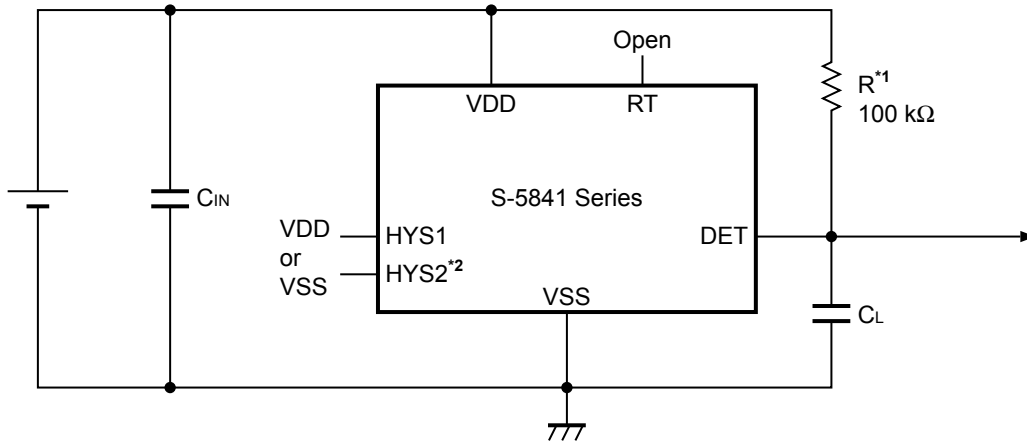

- \*1. Resistor (R) is unnecessary for the CMOS output product.
- \*2. The HYS2 pin is not equipped with SOT-23-5.

Figure 9

**Caution** The above connection diagram will not guarantee successful operation. Perform thorough evaluation using actual application to set the constant.

■ Precautions

- Set a capacitor ( $C_{IN}$ ) of 0.1  $\mu\text{F}$  or more between the VDD and VSS pin for stabilization.
- Set a capacitor ( $C_L$ ) of about 1  $\mu\text{F}$  for the DET pin to prevent malfunction caused by the noise when the power supply is applied.
- The S-5841 Series may oscillate by setting a capacitor to the RT pin. Set the RT pin open in use.
- If the RT pin is short-circuited to VSS, the DET pin becomes active in the S-5841 Series.
- Fix the HYS1 pin and the HYS2 pin VDD or VSS in use.
- Do not apply an electrostatic discharge to this IC that exceeds the performance ratings of the built-in electrostatic protection circuit.
- ABLIC Inc. claims no responsibility for any disputes arising out of or in connection with any infringement by products, including this IC, of patents owned by a third party.

■ Characteristics (Typical Data)

1. Current consumption vs. Power supply voltage characteristics

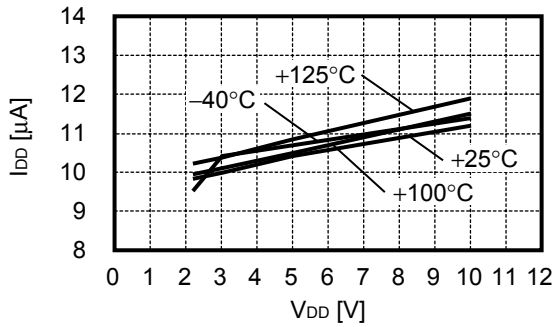

2. DET pin current "H" vs. Power supply voltage characteristics (CMOS output product only)

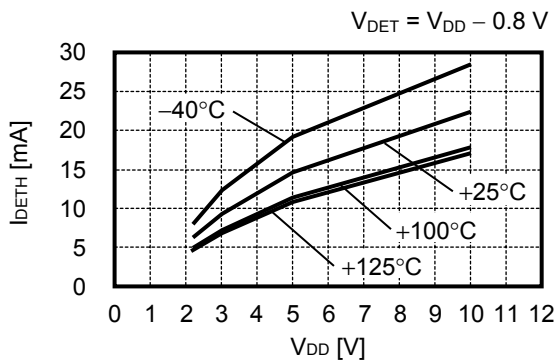

3. DET pin current "L" vs. Power supply voltage characteristics

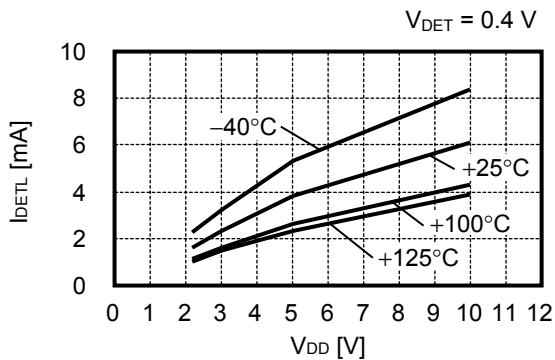

4. Noise suppression time vs. Power supply voltage characteristics

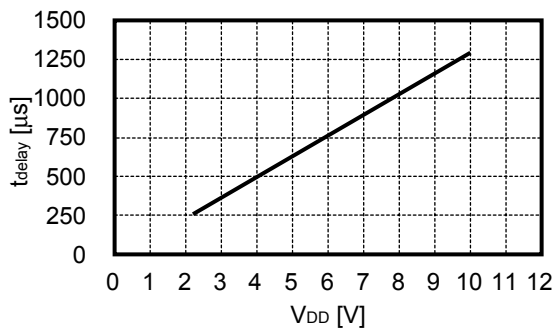



**5. Response against heat (Output voltage vs. Time)**

**5.1 When packages are put into the air of +100 degrees from the air of +25 degrees at t = 0 s**

$V_{DD} = 3.0\text{ V}$ ,  $C_L = 0\ \mu\text{F}$ , Detection temperature =  $+70^\circ\text{C}$ , Active "L"

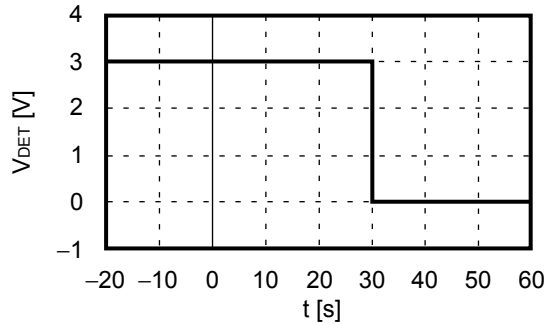

**5.2 When packages are put into the liquid of +100 degrees from the air of +25 degrees at t = 0 s**

$V_{DD} = 3.0\text{ V}$ ,  $C_L = 0\ \mu\text{F}$ , Detection temperature =  $+70^\circ\text{C}$ , Active "L"

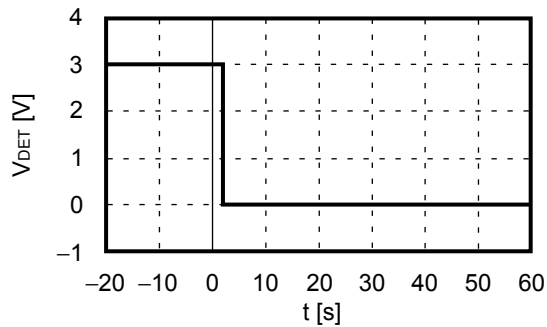

**6. Response against startup**

**6.1 The detection temperature or lower ( $T_a \leq +T_D$ )**

$C_L = 0\ \mu\text{F}$ , Active "L"

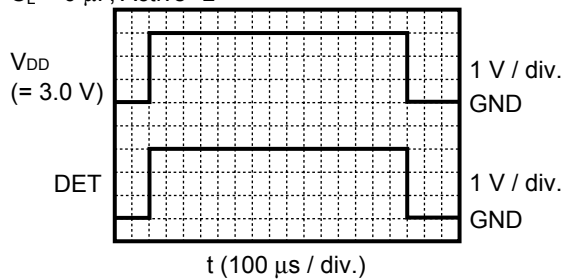

**6.2 Higher than the detection temperature ( $T_a > +T_D$ )**

$C_L = 0\ \mu\text{F}$ , Active "L"

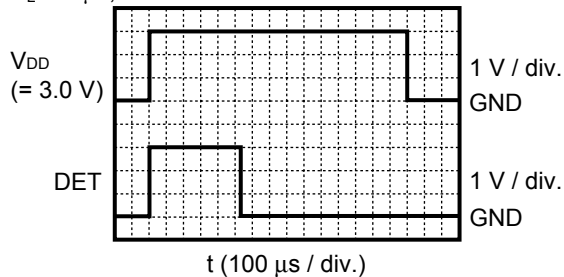

■ Marking Specifications

1. SOT-23-5

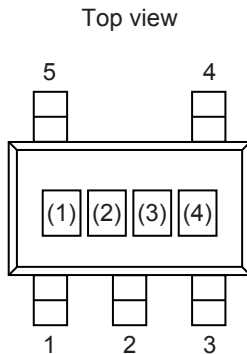

(1) to (3):  
(4):

Product code (refer to **Product name vs. Product code**)  
Lot number

Product name vs. Product code

Product Name	Product Code		
	(1)	(2)	(3)
S-5841A55D-M5T1x	T	H	B
S-5841A65D-M5T1x	T	H	C
S-5841A75D-M5T1x	T	H	D
S-5841A85D-M5T1x	T	H	E
S-5841A95D-M5T1x	T	H	F

Remark1. x: G or U

2. Please select products of environmental code = U for Sn 100%, halogen-free products.

2. SNT-6A

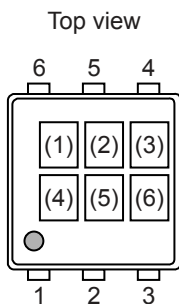

(1) to (3):  
(4) to (6):

Product code (refer to **Product name vs. Product code**)  
Lot number

Product name vs. Product code

Product Name	Product Code		
	(1)	(2)	(3)
S-5841A70A-I6T1U	T	I	G
S-5841A80A-I6T1U	T	I	H
S-5841A90A-I6T1U	T	I	I
S-5841A50D-I6T1U	T	H	A

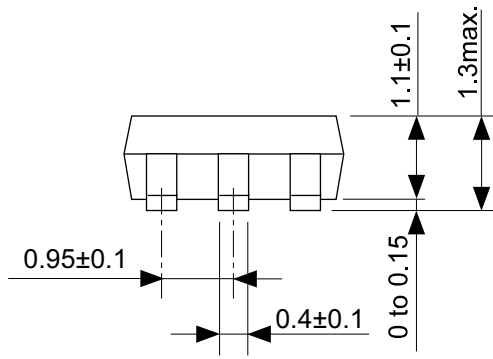
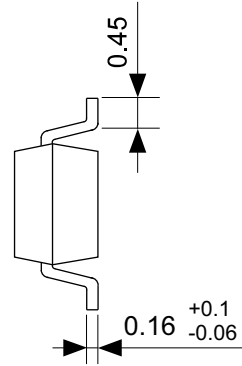
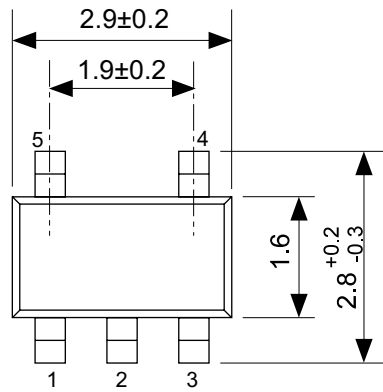

No. MP005-A-P-SD-1.3

TITLE	SOT235-A-PKG Dimensions
No.	MP005-A-P-SD-1.3
ANGLE	
UNIT	mm
<b>ABLIC Inc.</b>	

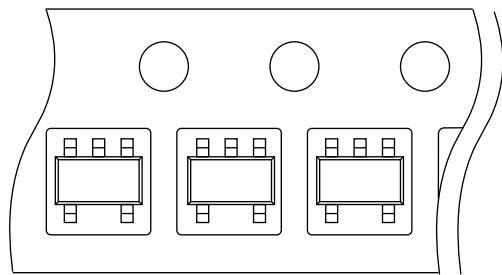
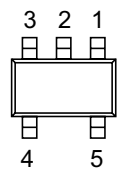
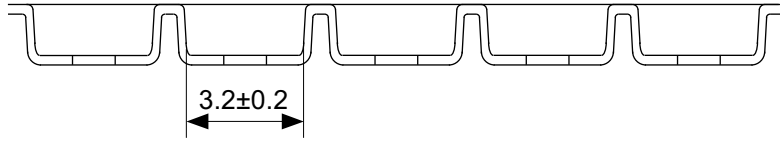
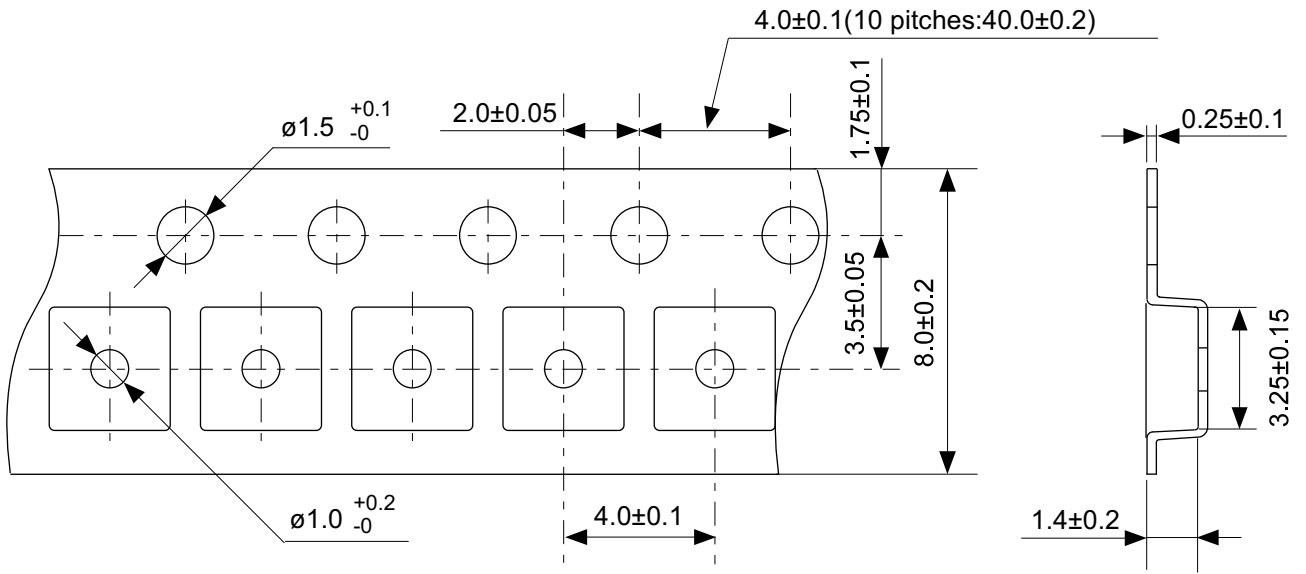

→ Feed direction

No. MP005-A-C-SD-2.1

TITLE	SOT235-A-Carrier Tape
No.	MP005-A-C-SD-2.1
ANGLE	
UNIT	mm
<b>ABLIC Inc.</b>	

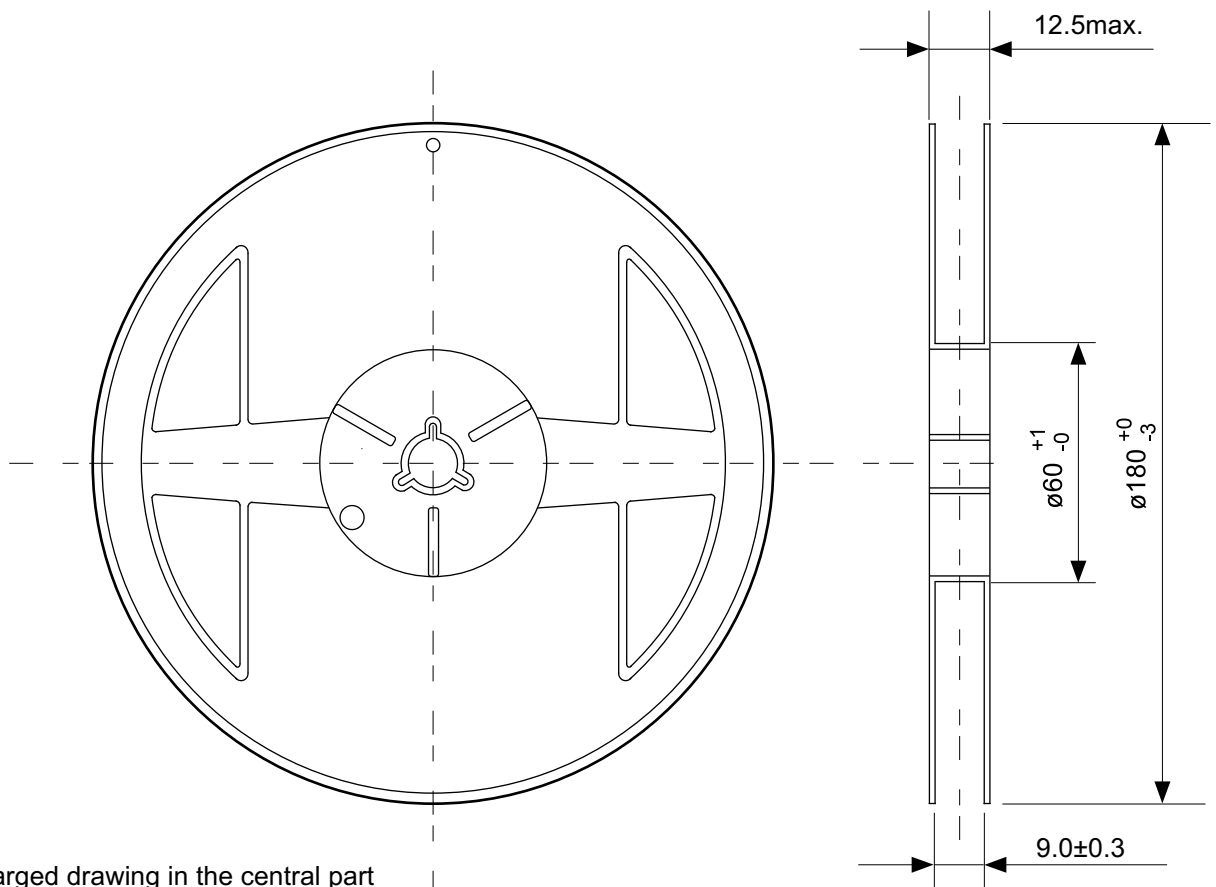

Enlarged drawing in the central part

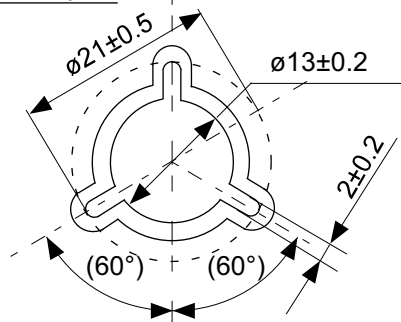

No. MP005-A-R-SD-1.1

TITLE	SOT235-A-Reel		
No.	MP005-A-R-SD-1.1		
ANGLE		QTY.	3,000
UNIT	mm		
<b>ABLIC Inc.</b>			

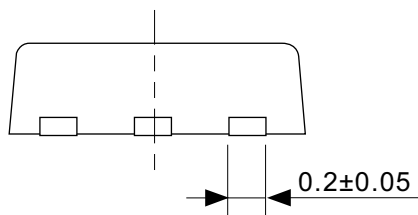
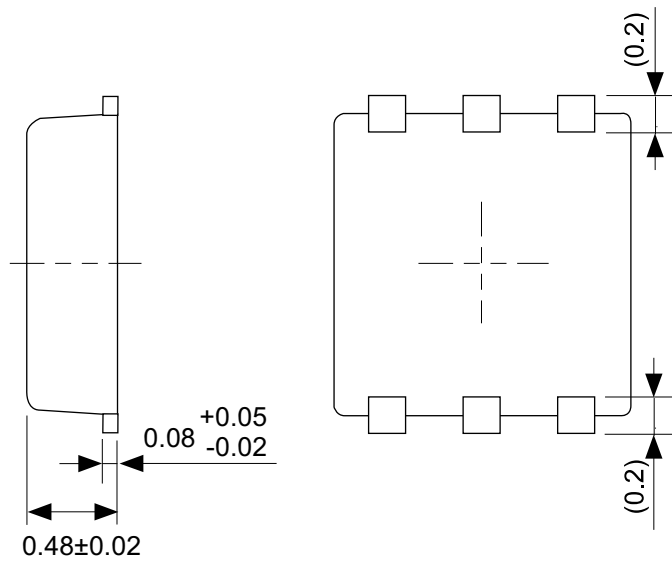
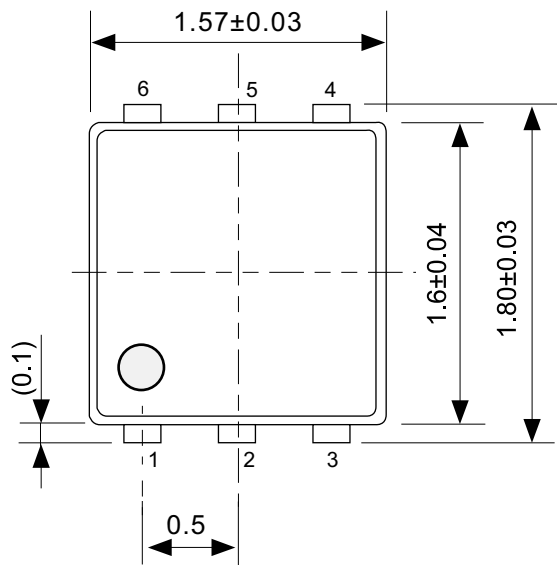

No. PG006-A-P-SD-2.1

TITLE	SNT-6A-A-PKG Dimensions
No.	PG006-A-P-SD-2.1
ANGLE	
UNIT	mm
<b>ABLIC Inc.</b>	

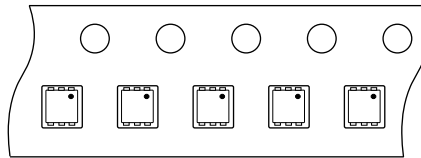
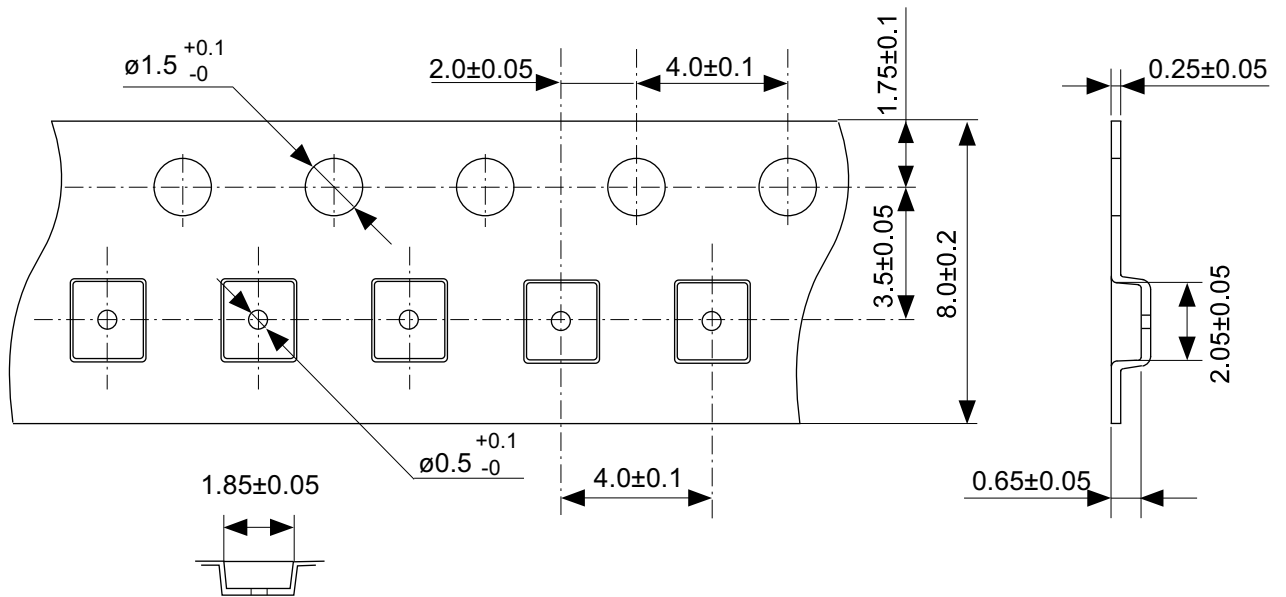

Feed direction →

No. PG006-A-C-SD-2.0

TITLE	SNT-6A-A-Carrier Tape
No.	PG006-A-C-SD-2.0
ANGLE	
UNIT	mm
<b>ABLIC Inc.</b>	

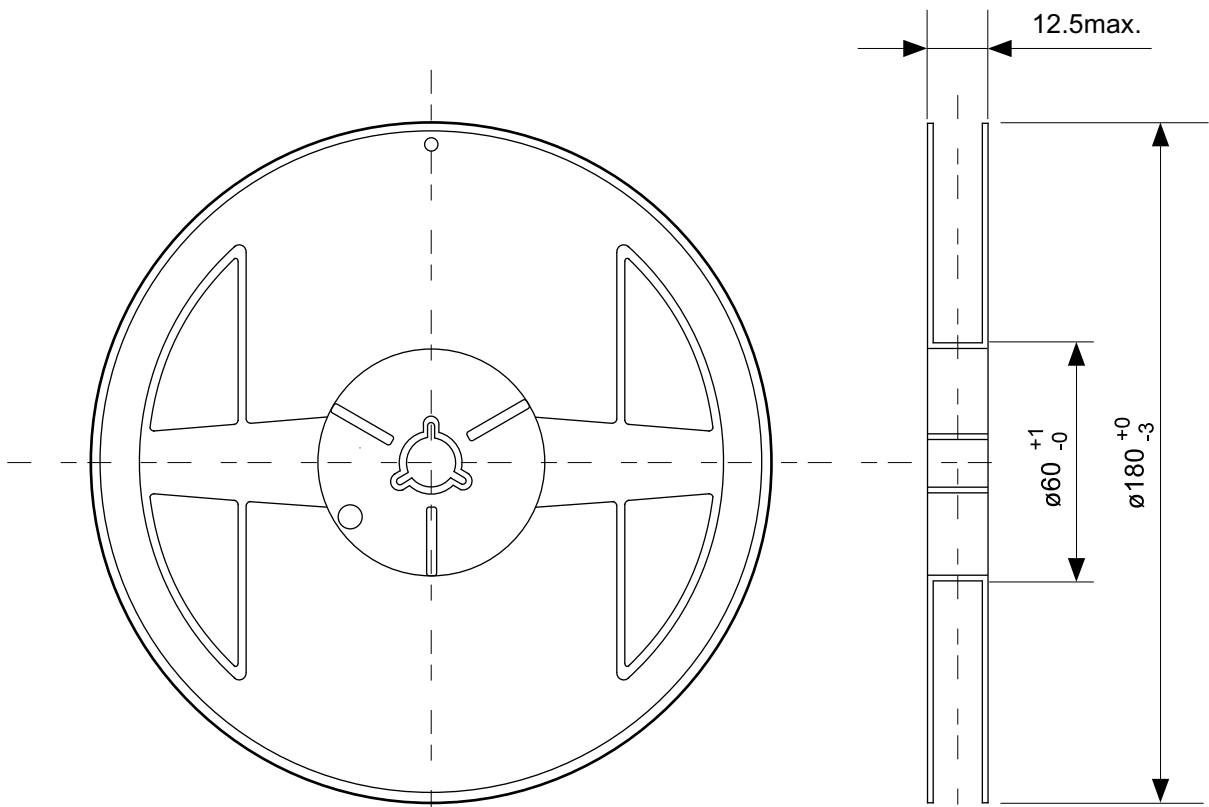

Enlarged drawing in the central part

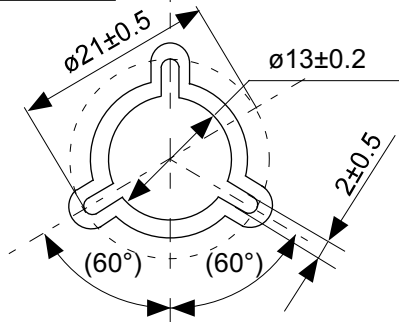

No. PG006-A-R-SD-1.0

TITLE	SNT-6A-A-Reel		
No.	PG006-A-R-SD-1.0		
ANGLE		QTY.	5,000
UNIT	mm		
<b>ABLIC Inc.</b>			



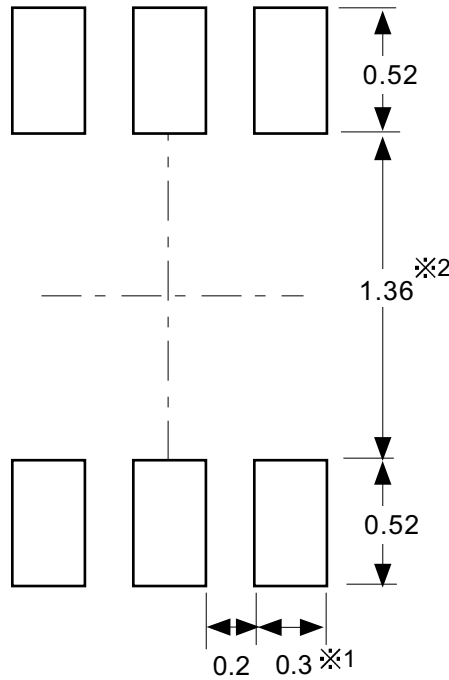

※1. ランドパターンの幅に注意してください (0.25 mm min. / 0.30 mm typ.).  
 ※2. パッケージ中央にランドパターンを広げないでください (1.30 mm ~ 1.40 mm)。

- 注意
1. パッケージのモールド樹脂下にシルク印刷やハンダ印刷などしないでください。
  2. パッケージ下の配線上のソルダーレジストなどの厚みをランドパターン表面から0.03 mm 以下にしてください。
  3. マスク開口サイズと開口位置はランドパターンと合わせてください。
  4. 詳細は“SNTパッケージ活用の手引き”を参照してください。

※1. Pay attention to the land pattern width (0.25 mm min. / 0.30 mm typ.).  
 ※2. Do not widen the land pattern to the center of the package ( 1.30 mm ~ 1.40 mm ).

- Caution**
1. Do not do silkscreen printing and solder printing under the mold resin of the package.
  2. The thickness of the solder resist on the wire pattern under the package should be 0.03 mm or less from the land pattern surface.
  3. Match the mask aperture size and aperture position with the land pattern.
  4. Refer to "SNT Package User's Guide" for details.

※1. 请注意焊盘模式的宽度 (0.25 mm min. / 0.30 mm typ.).  
 ※2. 请勿向封装中间扩展焊盘模式 (1.30 mm ~ 1.40 mm)。

- 注意
1. 请勿在树脂型封装的下面印刷丝网、焊锡。
  2. 在封装下、布线上的阻焊膜厚度 (从焊盘模式表面起) 请控制在 0.03 mm 以下。
  3. 钢网的开口尺寸和开口位置请与焊盘模式对齐。
  4. 详细内容请参阅 "SNT 封装的应用指南"。

No. PG006-A-L-SD-4.1

TITLE	SNT-6A-A -Land Recommendation
No.	PG006-A-L-SD-4.1
ANGLE	
UNIT	mm
<b>ABLIC Inc.</b>	

## Disclaimers (Handling Precautions)

1. All the information described herein (product data, specifications, figures, tables, programs, algorithms and application circuit examples, etc.) is current as of publishing date of this document and is subject to change without notice.
2. The circuit examples and the usages described herein are for reference only, and do not guarantee the success of any specific mass-production design.  
ABLIC Inc. is not liable for any losses, damages, claims or demands caused by the reasons other than the products described herein (hereinafter "the products") or infringement of third-party intellectual property right and any other right due to the use of the information described herein.
3. ABLIC Inc. is not liable for any losses, damages, claims or demands caused by the incorrect information described herein.
4. Be careful to use the products within their ranges described herein. Pay special attention for use to the absolute maximum ratings, operation voltage range and electrical characteristics, etc.  
ABLIC Inc. is not liable for any losses, damages, claims or demands caused by failures and / or accidents, etc. due to the use of the products outside their specified ranges.
5. Before using the products, confirm their applications, and the laws and regulations of the region or country where they are used and verify suitability, safety and other factors for the intended use.
6. When exporting the products, comply with the Foreign Exchange and Foreign Trade Act and all other export-related laws, and follow the required procedures.
7. The products are strictly prohibited from using, providing or exporting for the purposes of the development of weapons of mass destruction or military use. ABLIC Inc. is not liable for any losses, damages, claims or demands caused by any provision or export to the person or entity who intends to develop, manufacture, use or store nuclear, biological or chemical weapons or missiles, or use any other military purposes.
8. The products are not designed to be used as part of any device or equipment that may affect the human body, human life, or assets (such as medical equipment, disaster prevention systems, security systems, combustion control systems, infrastructure control systems, vehicle equipment, traffic systems, in-vehicle equipment, aviation equipment, aerospace equipment, and nuclear-related equipment), excluding when specified for in-vehicle use or other uses by ABLIC, Inc. Do not apply the products to the above listed devices and equipments.  
ABLIC Inc. is not liable for any losses, damages, claims or demands caused by unauthorized or unspecified use of the products.
9. In general, semiconductor products may fail or malfunction with some probability. The user of the products should therefore take responsibility to give thorough consideration to safety design including redundancy, fire spread prevention measures, and malfunction prevention to prevent accidents causing injury or death, fires and social damage, etc. that may ensue from the products' failure or malfunction.  
The entire system in which the products are used must be sufficiently evaluated and judged whether the products are allowed to apply for the system on customer's own responsibility.
10. The products are not designed to be radiation-proof. The necessary radiation measures should be taken in the product design by the customer depending on the intended use.
11. The products do not affect human health under normal use. However, they contain chemical substances and heavy metals and should therefore not be put in the mouth. The fracture surfaces of wafers and chips may be sharp. Be careful when handling these with the bare hands to prevent injuries, etc.
12. When disposing of the products, comply with the laws and ordinances of the country or region where they are used.
13. The information described herein contains copyright information and know-how of ABLIC Inc. The information described herein does not convey any license under any intellectual property rights or any other rights belonging to ABLIC Inc. or a third party. Reproduction or copying of the information from this document or any part of this document described herein for the purpose of disclosing it to a third-party is strictly prohibited without the express permission of ABLIC Inc.
14. For more details on the information described herein or any other questions, please contact ABLIC Inc.'s sales representative.
15. This Disclaimers have been delivered in a text using the Japanese language, which text, despite any translations into the English language and the Chinese language, shall be controlling.

2.4-2019.07