

FEATURES

Dynamic angle outputs

Quaternion, Euler, rotation matrix

0.1° (pitch, roll) and 0.3° (yaw) static accuracy

Triaxial, digital gyroscope, ±450°/sec dynamic range

±0.05° orthogonal alignment error

6°/hr in-run bias stability

0.3°/√hr angular random walk

0.01% nonlinearity

Triaxial, digital accelerometer, ±10 g

Triaxial, delta angle and delta velocity outputs

Triaxial, digital magnetometer, ±2.5 gauss

Digital pressure sensor, 300 mbar to 1100 mbar

Adaptive extended Kalman filter

Automatic covariance computation

Programmable reference reorientation

Programmable sensor disturbance levels

Configurable event-driven controls

Factory-calibrated sensitivity, bias, and axial alignment

Calibration temperature range: -40°C to +85°C

SPI-compatible serial interface

Programmable operation and control

4 FIR filter banks, 120 configurable taps

Digital I/O: data-ready alarm indicator, external clock

Optional external sample clock input: up to 2.4 kHz

Single-command self-test

Single-supply operation: 3.0 V to 3.6 V

2000 g shock survivability

APPLICATIONS

Platform stabilization, control, and pointing

Navigation

Instrumentation

Robotics

GENERAL DESCRIPTION

The [ADIS16480](#) iSensor® device is a complete inertial system that includes a triaxial gyroscope, a triaxial accelerometer, triaxial magnetometer, pressure sensor, and an extended Kalman filter (EKF) for dynamic orientation sensing. Each inertial sensor in the [ADIS16480](#) combines industry-leading iMEMS® technology with signal conditioning that optimizes dynamic performance. The factory calibration characterizes each sensor for sensitivity, bias, alignment, and linear acceleration (gyroscope bias). As a result, each sensor has its own dynamic compensation formulas that provide accurate sensor measurements. The sensors are further correlated and processed in the extended Kalman filter, which provides both automatic adaptive filtering, as well as user-programmable tuning. Thus, in addition to the IMU outputs, the device provides stable quaternion, Euler, and rotation matrix outputs in the local navigation frame.

The [ADIS16480](#) provides a simple, cost-effective method for integrating accurate, multi-axis inertial sensing into industrial systems, especially when compared with the complexity and investment associated with discrete designs. All necessary motion testing and calibration are part of the production process at the factory, greatly reducing system integration time. Tight orthogonal alignment simplifies inertial frame alignment in navigation systems. The SPI and register structure provide a simple interface for data collection and configuration control.

The [ADIS16480](#) uses the same footprint and connector system as the [ADIS16488A](#), which greatly simplifies the upgrade process. It comes in a module that is approximately 47 mm × 44 mm × 14 mm and has a standard connector interface. The [ADIS16480](#) provides an operating temperature range of -40°C to +105°C.

FUNCTIONAL BLOCK DIAGRAM

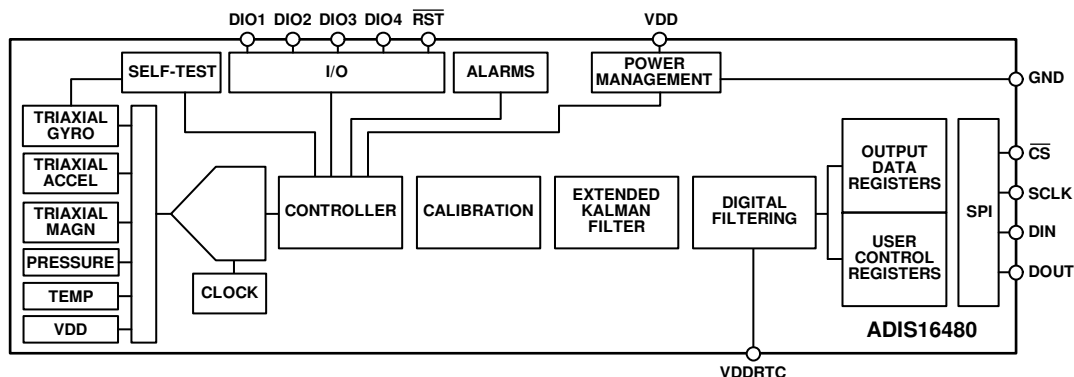

Figure 1.

10276-001

Rev. H

[Document Feedback](#)

Information furnished by Analog Devices is believed to be accurate and reliable. However, no responsibility is assumed by Analog Devices for its use, nor for any infringements of patents or other rights of third parties that may result from its use. Specifications subject to change without notice. No license is granted by implication or otherwise under any patent or patent rights of Analog Devices. Trademarks and registered trademarks are the property of their respective owners.

One Technology Way, P.O. Box 9106, Norwood, MA 02062-9106, U.S.A.
Tel: 781.329.4700 ©2012–2019 Analog Devices, Inc. All rights reserved.
[Technical Support](#) www.analog.com

TABLE OF CONTENTS

Features	1	Averaging/Decimation Filter	26
Applications.....	1	Magnetometer/Barometer.....	26
General Description	1	FIR Filter Banks	27
Functional Block Diagram	1	Extended Kalman Filter	29
Revision History	3	Algorithm	29
Specifications.....	4	Covariance Terms.....	29
Timing Specifications	7	Reference Frame.....	30
Absolute Maximum Ratings.....	9	Reference Transformation Matrix.....	30
ESD Caution.....	9	Declination.....	31
Pin Configuration and Function Descriptions.....	10	Adaptive Operation.....	31
Typical Performance Characteristics	11	Calibration.....	33
Basic Operation.....	12	Gyroscopes	33
Register Structure	12	Accelerometers	34
SPI Communication.....	13	Magnetometers	34
Device Configuration	13	Barometers	36
Reading Sensor Data	13	Restoring Factory Calibration	36
User Registers.....	14	Point of Percussion Alignment.....	36
Output Data Registers.....	18	Alarms.....	37
Inertial Sensor Data Format.....	18	Static Alarm Use.....	37
Rotation Rate (Gyroscope).....	18	Dynamic Alarm Use	37
Acceleration.....	19	System Controls	39
Delta Angles	19	Global Commands	39
Delta Velocity.....	20	Memory Management	39
Magnetometers	21	General-Purpose I/O	40
Roll, Pitch, Yaw Angles	21	Power Management	40
Initial Conditions	21	Applications Information	42
Rotation Matrix Data	22	Mounting Tips	42
Barometer	23	Evaluation Tools	43
Internal Temperature	23	Power Supply Considerations.....	43
Status/Alarm Indicators.....	24	X-Ray Sensitivity	43
Firmware Revision	25	Outline Dimensions	44
Product Identification.....	25	Ordering Guide	44
Digital Signal Processing	26		
Gyroscopes/Accelerometers.....	26		

REVISION HISTORY**1/2019—Rev. G to Rev. H**

Added Endnote 4, Table 1; Renumbered Sequentially	6
Added X-Ray Sensitivity Section	43

10/2017—Rev. F to Rev. G

Changes to General Description Section	1
Changes to Logic 0 Input Current, I_{IL} Parameter, Table 1	5
Added Note 7, Table 1; Renumbered Sequentially	6
Changed PC-Based Evaluation, EVAL-ADIS Section to PC-Based Evaluation, EVAL-ADIS2 Section	43
Changes to PC-Based Evaluation, EVAL-ADIS2 Section	43

10/2016—Rev. E to Rev. F

Changes to Figure 19	18
Changes to Figure 30 and Figure 31	43

6/2015—Rev. D to Rev. E

Changes to Figure 28	42
Changes to Ordering Guide	44

2/2015—Rev. C to Rev. D

Changes to Features Section and General Description Section	1
Changes to Table 1	4
Changes to t_2 Parameter, Table 2, and Figure 2	7
Added Table 3; Renumbered Sequentially	7
Changes to Figure 4	8
Change to Operating Temperature Range, Table 4	9
Change to Dual Memory Structure Section	13
Change to Linear Acceleration on Effect on Gyroscope Bias Section	33
Changes to Input Sync/Clock Control Section, Table 151, and Power Management Section	40
Changes to Ordering Guide	44

4/2014—Rev. B to Rev. C

Changes to Features Section	1
Change to Nonlinearity, Barometer Parameter, Endnote 5, and Endnote 12, Table 2	5
Changes to Table 9	16
Changes to Delta Angles Section	19
Changes to Magnetometer/Barometer Section	25
Changes to Linear Acceleration on Effect on Gyroscope Bias Section	32
Change to Manual Bias Correction Section	33
Change to Static Alarm Use Section	36
Change to Software Reset Section	38
Changes to General Purpose I/O Section	39
Changes to Mounting Tips Section	41

1/2014—Rev. A to Rev. B

Moved Revision History	3
Change to t_2 Parameter, Table 2	7
Changes to Figure 6	9
Changes to Delta Angles Section	18
Changes to Delta Velocity Section and Table 34	19
Changes to Initial Conditions Section	20
Changes to Table 42	21
Changes to Status/Alarm Indicators Section	23
Changes to Table 94, Automatic EKF Divergence Reset Control Bit Section, and Body Frame/Local Navigation Frame Bit Section	30
Change to Magnetometers Section	33
Changes to Table 146	38
Deleted Prototype Interface Board Section and Mechanical Design Tips Section	39
Added Mounting Tips Section	41
Added Evaluation Tools Section and Power Supply Considerations Section	42
Updated Outline Dimensions	43
Changes to Ordering Guide	43

2/2013—Rev. 0 to Rev. A

Changes to Table 1	3
Changes to Table 2 and Figure 2	6
Changes to Table 9	12
Changes to Table 94, Bit 3 and Body Frame/Local Navigation Frame Bit Section	29
Deleted Installation Tips Section; Added Mechanical Design Tips Section; Changes to Prototype Interface Board Section, Figure 29, and Figure 30	39
Added Connector-Up Design Tips Section Figure 31, and Figure 32, Renumbered Sequentially	40

5/2012—Revision 0: Initial Version

SPECIFICATIONS

T_A = 25°C, VDD = 3.3 V, angular rate = 0°/sec, dynamic range = ±450°/sec ± 1 g, 300 mbar to 1100 mbar, unless otherwise noted.

Table 1.

Parameter	Test Conditions/Comments	Min	Typ	Max	Unit
ANGLE OUTPUTS					
Euler Dynamic Range	Yaw and roll (Euler) Pitch (Euler) Rotation matrix, quaternion			±180 ±90 ±180	Degrees Degrees Degree
Sensitivity			0.0055		Degrees/LSB
Static Accuracy ¹	Pitch and roll Yaw		0.1 0.3		Degrees Degrees
Dynamic Accuracy ¹	Pitch and roll Yaw		0.3 0.5		Degrees Degrees
GYROSCOPES					
Dynamic Range		±450		±480	°/sec
Sensitivity	x_GYRO_OUT and x_GYRO_LOW (32-bit)		3.052 × 10 ⁻⁷		°/sec/LSB
Repeatability ²	-40°C ≤ T _A ≤ +85°C			±1	%
Sensitivity Temperature Coefficient	-40°C ≤ T _A ≤ +85°C, 1 σ		±35		ppm/°C
Misalignment	Axis to axis Axis to frame (package)		±0.05 ±1.0		Degrees Degrees
Nonlinearity	Best-fit straight line, FS = 450°/sec		0.01		% of FS
Initial Bias Error			±0.2		°/sec
In-Run Bias Stability	1 σ		6.25		°/hr
Angular Random Walk	1 σ		0.3		°/√hr
Bias Temperature Coefficient	-40°C ≤ T _A ≤ +85°C, 1 σ		±0.0025		°/sec/°C
Linear Acceleration Effect on Bias	Any axis, 1 σ (CONFIG[7] = 1)		0.009		°/sec/g
Output Noise	No filtering		0.16		°/sec rms
Rate Noise Density	f = 25 Hz, no filtering		0.0066		°/sec/√Hz rms
3 dB Bandwidth			330		Hz
Sensor Resonant Frequency			18		kHz
ACCELEROMETERS					
Dynamic Range	Each axis	±10			g
Sensitivity	x_ACCL_OUT and x_ACCL_LOW (32-bit)		1.221 × 10 ⁻⁸		g/LSB
Repeatability	-40°C ≤ T _A ≤ +85°C			±0.5	%
Sensitivity Temperature Coefficient	-40°C ≤ T _A ≤ +85°C, 1 σ		±25		ppm/°C
Misalignment	Axis to axis Axis to frame (package)		±0.035 ±1.0		Degrees Degrees
Nonlinearity	Best-fit straight line, ±10 g		0.1		% of FS
Bias Repeatability ^{3, 4}	-40°C ≤ T _A ≤ +85°C, 1 σ		±16		mg
In-Run Bias Stability	1 σ		0.1		mg
Velocity Random Walk	1 σ		0.029		m/sec/√hr
Bias Temperature Coefficient	-40°C ≤ T _A ≤ +85°C		±0.1		mg/°C
Output Noise	No filtering		1.5		mg rms
Noise Density	f = 25 Hz, no filtering		0.067		mg/√Hz rms
3 dB Bandwidth			330		Hz
Sensor Resonant Frequency			5.5		kHz

Parameter	Test Conditions/Comments	Min	Typ	Max	Unit
MAGNETOMETER					
Dynamic Range		±2.5			gauss
Sensitivity			0.1		mgauss/LSB
Initial Sensitivity Tolerance				±2	%
Sensitivity Temperature Coefficient	1 σ		275		ppm/°C
Misalignment	Axis to axis		0.25		Degrees
	Axis to frame (package)		0.5		Degrees
Nonlinearity	Best fit straight line		0.5		% of FS
Initial Bias Error	0 gauss stimulus		±15		mgauss
Bias Temperature Coefficient	-40°C ≤ T _A ≤ +85°C, 1 σ		0.3		mgauss/°C
Output Noise	No filtering		0.45		mgauss
Noise Density	f = 25 Hz, no filtering		0.054		mgauss/ $\sqrt{\text{Hz}}$
3 dB Bandwidth			330		Hz
BAROMETER					
Pressure Range		300		1100	mbar
	Extended	10		1200	mbar
Sensitivity	BAROM_OUT and BAROM_LOW (32-bit)		6.1 × 10 ⁻⁷		mbar/LSB
Error with Supply			0.04		%/V
Total Error			4.5		mbar
Relative Error ⁵	-40°C to +85°C		2.5		mbar
Nonlinearity ⁶	Best fit straight line, FS = 1100 mbar		0.1		% of FS
	-40°C to +85°C		0.2		% of FS
Linear-g Sensitivity	±1 g, 1 σ		0.005		mbar/g
Noise			0.025		mbar rms
TEMPERATURE SENSOR					
Scale Factor	Output = 0x0000 at 25°C (±5°C)		0.00565		°C/LSB
LOGIC INPUTS⁷					
Input High Voltage, V _{IH}		2.0			V
Input Low Voltage, V _{IL}				0.8	V
$\overline{\text{CS}}$ Wake-Up Pulse Width		20			μs
Logic 1 Input Current, I _{IH}	V _{IH} = 3.3 V			10	μA
Logic 0 Input Current, I _{IL}	V _{IL} = 0 V				
All Pins Except $\overline{\text{RST}}$, $\overline{\text{CS}}$				10	μA
$\overline{\text{RST}}$, $\overline{\text{CS}}$ Pins ⁸			0.33		mA
Input Capacitance, C _{IN}			10		pF
DIGITAL OUTPUTS					
Output High Voltage, V _{OH}	I _{SOURCE} = 0.5 mA	2.4			V
Output Low Voltage, V _{OL}	I _{SINK} = 2.0 mA			0.4	V
FLASH MEMORY					
Endurance ⁹		100,000			Cycles
Data Retention ¹⁰	T _J = 85°C	20			Years
FUNCTIONAL TIMES¹¹					
Power-On Start-Up Time	Time until inertial sensor data is available		400 ± 160		ms
Reset Recovery Time ¹²	Initiated by $\overline{\text{RST}}$ or GLOB_CMD[7] = 1		400 ± 160		ms
Sleep Mode Recovery Time			700		μs
Flash Memory Update Time			1.1	6.8	sec
Flash Memory Test Time			53		ms
Automatic Self-Test Time	Using internal clock, 100 SPS		12		ms
CONVERSION RATE					
Initial Clock Accuracy			2.46		kSPS
Temperature Coefficient			0.02		%
Sync Input Clock ¹³		0.7		2.4	kHz

Parameter	Test Conditions/Comments	Min	Typ	Max	Unit
POWER SUPPLY, VDD Power Supply Current ¹⁴	Operating voltage range Normal mode, VDD = 3.3 V, $\mu \pm \sigma$ Sleep mode, VDD = 3.3 V Power-down mode, VDD = 3.3 V	3.0	254 12.2 45	3.6	V mA mA μ A
POWER SUPPLY, VDDRTC Real-Time Clock Supply Current	Operating voltage range Normal mode, VDDRTC = 3.3 V	3.0	13	3.6	V μ A

¹ Accuracy specifications assume calibration of accelerometers and magnetometers to address sensor drift and local influences on magnetic fields.

² The repeatability specifications represent analytical projections that are based off of the following drift contributions and conditions: temperature hysteresis (–40°C to +85°C), electronics drift (High-Temperature Operating Life test: +110°C, 500 hours), drift from temperature cycling (JEDEC22, Method A104-C, Method N, 500 cycles, –40°C to +85°C), rate random walk (10 year projection), and broadband noise.

³ Bias repeatability describes a long-term behavior, over a variety of conditions. Short-term repeatability is related to the in-run bias stability and noise density specifications.

⁴ X-ray exposure may degrade this performance metric.

⁵ The relative error assumes that the initial error, at 25°C, is corrected in the end application.

⁶ Specification assumes a full scale (FS) of 1000 mbar.

⁷ The digital I/O signals use a 3.3 V system.

⁸ \overline{RST} and \overline{CS} pins are connected to the VDD pin through 10 k Ω pull-up resistors.

⁹ Endurance is qualified as per JEDEC Standard 22, Method A117, and measured at –40°C, +25°C, +85°C, and +125°C.

¹⁰ The data retention specification assumes a junction temperature (T_j) of 85°C as per JEDEC Standard 22, Method A117. Data retention lifetime decreases with T_j .

¹¹ These times do not include thermal settling, internal filter response times, or EKF start-up times (~825 ms), which may affect overall accuracy, with respect to time.

¹² The \overline{RST} line must be in a low state for at least 10 μ s to assure a proper reset initiation and recovery.

¹³ The device functions at clock rates below 0.7 kHz, but at reduced performance levels.

¹⁴ Supply current transients can reach 600 mA during start-up and reset recovery.

TIMING SPECIFICATIONS

T_A = 25°C, VDD = 3.3 V, unless otherwise noted.

Table 2.

Parameter	Description	Min ¹	Normal Mode		Unit
			Typ	Max ¹	
f _{SCLK}	Serial clock	0.01		15	MHz
t _{STALL} ²	Stall period between data	2			μs
t _{CLS}	Serial clock low period	31			ns
t _{CHS}	Serial clock high period	31			ns
t _{CS}	Chip select to clock edge	32			ns
t _{DAV}	DOUT valid after SCLK edge			10	ns
t _{DSU}	DIN setup time before SCLK rising edge	2			ns
t _{DHD}	DIN hold time after SCLK rising edge	2			ns
t _{DR} , t _{DF}	DOUT rise/fall times, ≤100 pF loading		3	8	ns
t _{DSOE}	CS assertion to data out active	0		11	ns
t _{HD}	SCLK edge to data out invalid	0			ns
t _{SFS}	Last SCLK edge to CS deassertion	32			ns
t _{DSHI}	CS deassertion to data out high impedance	0		9	ns
t ₁	Input sync pulse width	5			μs
t ₂	Input sync to data invalid		635		μs
t ₃	Input sync period	417			μs

¹ Guaranteed by design and characterization, but not tested in production.

² See Table 3 for exceptions to the stall time rating.

Table 3. Register Specific Stall Times

Register	Function	Minimum Stall Time (μs)
FNCTIO_CTRL	Configure DIOx functions	60
FLTR_BNK0	Enable/select FIR filter banks	320
FLTR_BNK1	Enable/select FIR filter banks	320
NULL_CFG	Configure autonull bias function	10
GLOB_CMD[1]	Self-test	12,000
GLOB_CMD[2]	Memory test	50,000
GLOB_CMD[3]	Flash memory update	375,000
GLOB_CMD[6]	Flash memory test	75,000
GLOB_CMD[7]	Software reset	12,000

Timing Diagrams

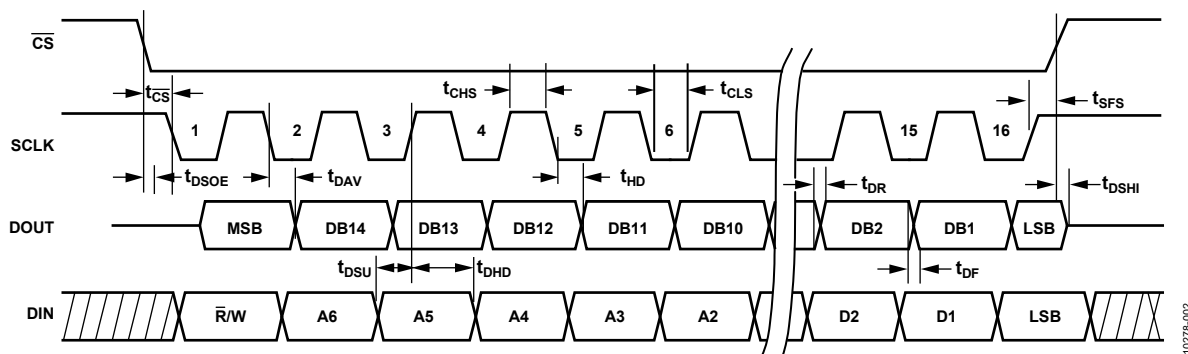

Figure 2. SPI Timing and Sequence

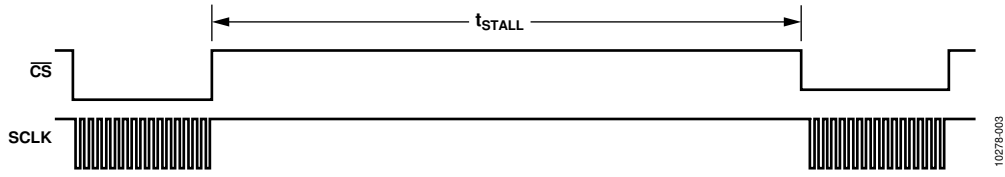

Figure 3. Stall Time and Data Rate

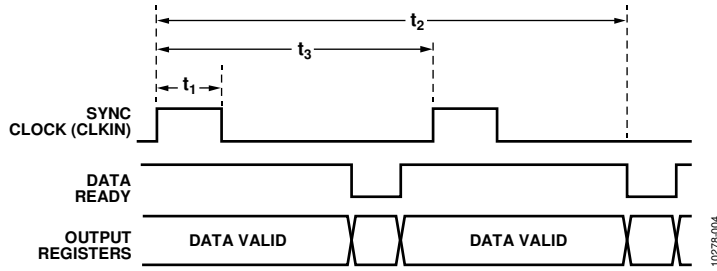

Figure 4. Input Clock Timing Diagram

ABSOLUTE MAXIMUM RATINGS

Table 4.

Parameter	Rating
Acceleration	
Any Axis, Unpowered	2000 g
Any Axis, Powered	2000 g
VDD to GND	−0.3 V to +3.6 V
Digital Input Voltage to GND	−0.3 V to VDD + 0.2 V
Digital Output Voltage to GND	−0.3 V to VDD + 0.2 V
Operating Temperature Range	−40°C to +105°C
Storage Temperature Range	−65°C to +150°C ¹
Barometric Pressure	2 bar

¹ Extended exposure to temperatures that are lower than −40°C or higher than +105°C can adversely affect the accuracy of the factory calibration.

Stresses at or above those listed under Absolute Maximum Ratings may cause permanent damage to the product. This is a stress rating only; functional operation of the product at these or any other conditions above those indicated in the operational section of this specification is not implied. Operation beyond the maximum operating conditions for extended periods may affect product reliability.

Table 5. Package Characteristics

Package Type	θ_{JA}	θ_{JC}	Device Weight
24-Lead Module (ML-24-6)	22.8°C/W	10.1°C/W	48 g

ESD CAUTION



ESD (electrostatic discharge) sensitive device. Charged devices and circuit boards can discharge without detection. Although this product features patented or proprietary protection circuitry, damage may occur on devices subjected to high energy ESD. Therefore, proper ESD precautions should be taken to avoid performance degradation or loss of functionality.

PIN CONFIGURATION AND FUNCTION DESCRIPTIONS

ADIS16480
TOP VIEW
(Not to Scale)

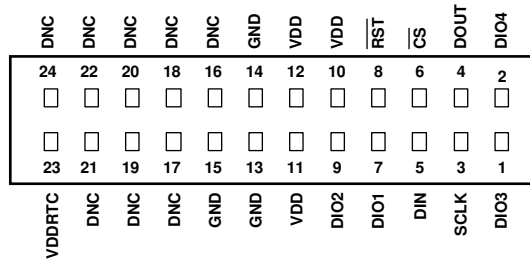

- NOTES
1. THIS REPRESENTATION DISPLAYS THE TOP VIEW PINOUT FOR THE MATING SOCKET CONNECTOR.
 2. THE ACTUAL CONNECTOR PINS ARE NOT VISIBLE FROM THE TOP VIEW.
 3. MATING CONNECTOR: SAMTEC CLM-112-02 OR EQUIVALENT.
 4. DNC = DO NOT CONNECT TO THESE PINS.

10278-005

Figure 5. Mating Connector Pin Assignments

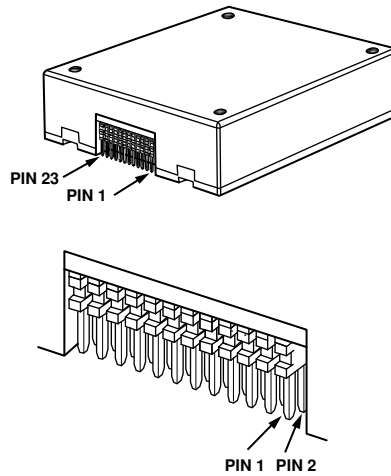

10278-206

Figure 6. Axial Orientation (Top Side Facing Up)

Table 6. Pin Function Descriptions

Pin No.	Mnemonic	Type	Description
1	DIO3	Input/output	Configurable Digital Input/Output.
2	DIO4	Input/output	Configurable Digital Input/Output.
3	SCLK	Input	SPI Serial Clock.
4	DOUT	Output	SPI Data Output. Clocks output on SCLK falling edge.
5	DIN	Input	SPI Data Input. Clocks input on SCLK rising edge.
6	CS	Input	SPI Chip Select.
7	DIO1	Input/output	Configurable Digital Input/Output.
8	RST	Input	Reset.
9	DIO2	Input/output	Configurable Digital Input/Output.
10, 11, 12	VDD	Supply	Power Supply.
13, 14, 15	GND	Supply	Power Ground.
16 to 22, 24	DNC	Not applicable	Do Not Connect. Do not connect to these pins.
23	VDDRTC	Supply	Real-Time Clock Power Supply.

TYPICAL PERFORMANCE CHARACTERISTICS

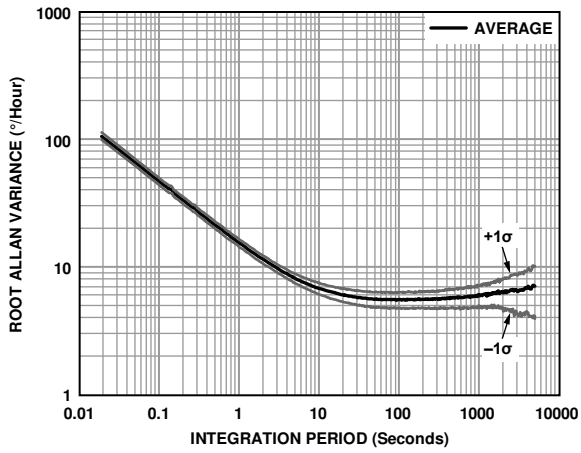

Figure 7. Gyroscope Allan Variance, 25°C

10278-007

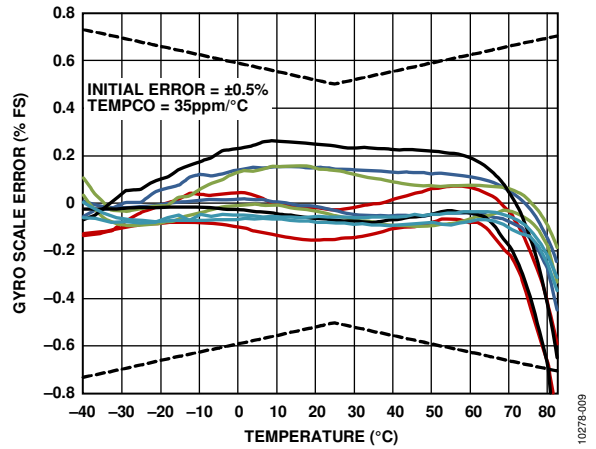

Figure 9. Gyroscope Scale (Sensitivity) Error and Hysteresis vs. Temperature

10278-009

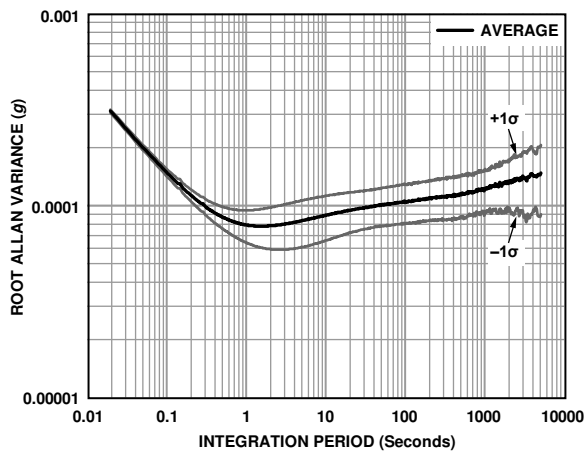

Figure 8. Accelerometer Allan Variance, 25°C

10278-008

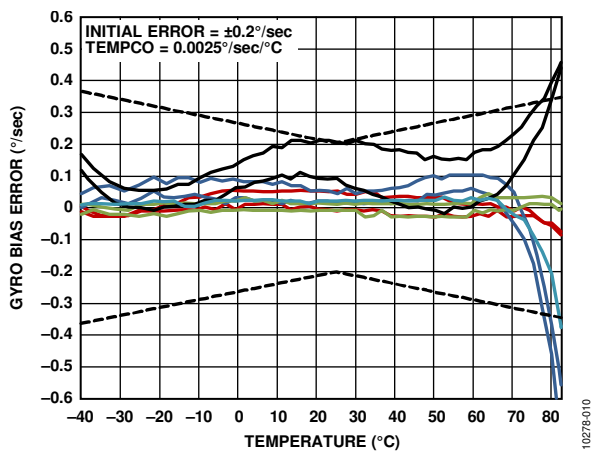

Figure 10. Gyroscope Bias Error and Hysteresis vs. Temperature

10278-010

BASIC OPERATION

The ADIS16480 is an autonomous sensor system that starts up on its own when it has a valid power supply. After running through its initialization process, it begins sampling, processing, and loading calibrated sensor data into the output registers, which are accessible using the SPI port. The SPI port typically connects to a compatible port on an embedded processor, using the connection diagram in Figure 11. The four SPI signals facilitate synchronous, serial data communication. Connect \overline{RST} (see Table 6) to VDD or leave it open for normal operation. The factory default configuration provides users with a data-ready signal on the DIO2 pin, which pulses high when new data is available in the output data registers.

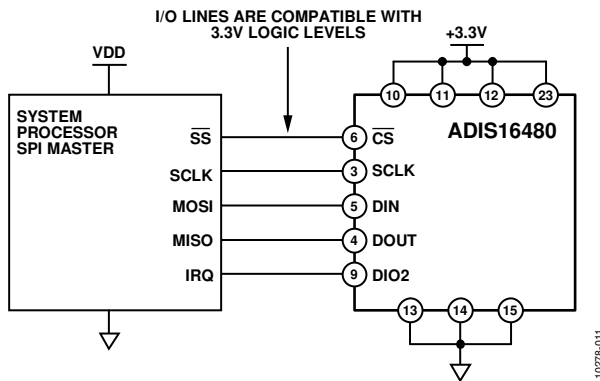

Figure 11. Electrical Connection Diagram

Table 7. Generic Master Processor Pin Names and Functions

Mnemonic	Function
SS	Slave select
IRQ	Interrupt request
MOSI	Master output, slave input
MISO	Master input, slave output
SCLK	Serial clock

Embedded processors typically use control registers to configure their serial ports for communicating with SPI slave devices such as the ADIS16480. Table 8 provides a list of settings, which describe the SPI protocol of the ADIS16480. The initialization routine of the master processor typically establishes these settings using firmware commands to write them into its serial control registers.

Table 8. Generic Master Processor SPI Settings

Processor Setting	Description
Master	The ADIS16480 operates as a slave
SCLK \leq 15 MHz	Maximum serial clock rate
SPI Mode 3	CPOL = 1 (polarity), and CPHA = 1 (phase)
MSB-First Mode	Bit sequence
16-Bit Mode	Shift register/data length

REGISTER STRUCTURE

The register structure and SPI port provide a bridge between the sensor processing system and an external, master processor. It contains both output data and control registers. The output data registers include the latest sensor data, a real-time clock, error flags, alarm flags, and identification data. The control registers include sample rate, filtering, input/output, alarms, calibration, EKF tuning, and diagnostic configuration options. All communication between the ADIS16480 and an external processor involves either reading or writing to one of the user registers.

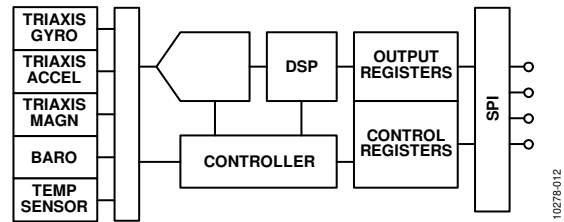

Figure 12. Basic Operation

The register structure uses a paged addressing scheme that is composed of 13 pages, with each one containing 64 register locations. Each register is 16 bits wide, with each byte having its own unique address within the memory map of that page. The SPI port has access to one page at a time, using the bit sequence in Figure 17. Select the page to activate for SPI access by writing its code to the PAGE_ID register. Read the PAGE_ID register to determine which page is currently active. Table 9 displays the PAGE_ID contents for each page, along with their basic functions. The PAGE_ID register is located at Address 0x00 on every page.

Table 9. User Register Page Assignments

Page	PAGE_ID	Function
0	0x00	Output data, clock, identification
1	0x01	Reserved
2	0x02	Calibration
3	0x03	Control: sample rate, filtering, I/O, alarms
4	0x04	Serial number
5	0x05	FIR Filter Bank A Coefficient 0 to Coefficient 59
6	0x06	FIR Filter Bank A, Coefficient 60 to Coefficient 119
7	0x07	FIR Filter Bank B, Coefficient 0 to Coefficient 59
8	0x08	FIR Filter Bank B, Coefficient 60 to Coefficient 119
9	0x09	FIR Filter Bank C, Coefficient 0 to Coefficient 59
10	0x0A	FIR Filter Bank C, Coefficient 60 to Coefficient 119
11	0x0B	FIR Filter Bank D, Coefficient 0 to Coefficient 59
12	0x0C	FIR Filter Bank D, Coefficient 60 to Coefficient 119

SPI COMMUNICATION

The SPI port supports full duplex communication, as shown in Figure 17, which enables external processors to write to DIN while reading DOUT, if the previous command was a read request. Figure 17 provides a guideline for the bit coding on both DIN and DOUT.

DEVICE CONFIGURATION

The SPI provides write access to the control registers, one byte at a time, using the bit assignments shown in Figure 17. Each register has 16 bits, where Bits[7:0] represent the lower address (listed in Table 10) and Bits[15:8] represent the upper address. Write to the lower byte of a register first, followed by a write to its upper byte. The only register that changes with a single write to its lower byte is the PAGE_ID register. For a write command, the first bit in the DIN sequence is set to 1. Address Bits[A6:A0] represent the target address, and Data Command Bits[DC7:DC0] represent the data being written to the location. Figure 13 provides an example of writing 0x03 to Address 0x00 (PAGE_ID [7:0]), using DIN = 0x8003. This write command activates the control page for SPI access.

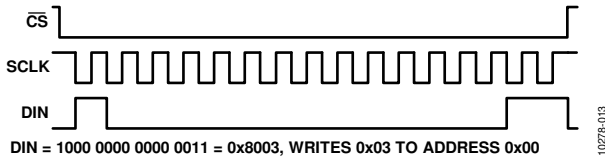

Figure 13. SPI Sequence for Activating the Control Page (DIN = 0x8003)

Dual Memory Structure

Writing configuration data to a control register updates its SRAM contents, which are volatile. After optimizing each relevant control register setting in a system, use the manual flash update command, which is located in GLOB_CMD[3] on Page 3 of the register map. Activate the manual flash update command by turning to Page 3 (DIN = 0x8003) and setting GLOB_CMD[3] = 1 (DIN = 0x8208, then DIN = 0x8300). For a flash memory update, make sure that the power supply is within specification for the entire processing time (see Table 1). Table 10 provides a memory map for all of the user registers, which includes a column of flash backup information. A yes in this column indicates that a register has a mirror location in flash and, when backed up properly, automatically restores itself during startup or after a reset. Figure 14 provides a diagram of the dual memory structure used to manage operation and store critical user settings.

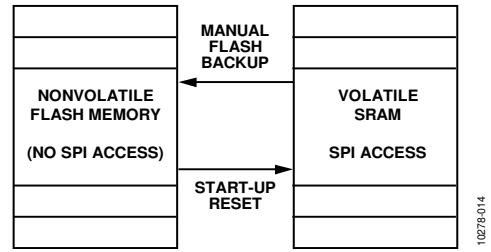

Figure 14. SRAM and Flash Memory Diagram

READING SENSOR DATA

The ADIS16480 automatically starts up and activates Page 0 for data register access. Write 0x00 to the PAGE_ID register (DIN = 0x8000) to activate Page 0 for data access after accessing any other page. A single register read requires two 16-bit SPI cycles. The first cycle requests the contents of a register using the bit assignments in Figure 17, and then the register contents follow DOUT during the second sequence. The first bit in a DIN command is zero, followed by either the upper or lower address for the register. The last eight bits are don't care, but the SPI requires the full set of 16 SCLKs to receive the request. Figure 15 includes two register reads in succession, which starts with DIN = 0x1A00 to request the contents of the Z_GYRO_OUT register and follows with 0x1800 to request the contents of the Z_GYRO_LOW register.



Figure 15. SPI Read Example

Figure 16 provides an example of the four SPI signals when reading PROD_ID in a repeating pattern. This is a good pattern to use for troubleshooting the SPI interface setup and communications because the contents of PROD_ID are predefined and stable.

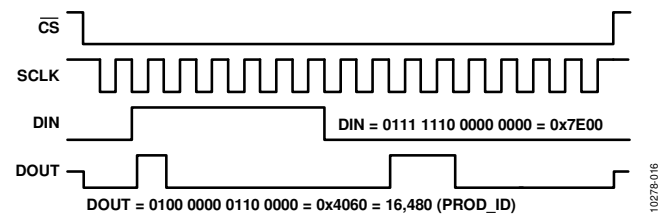
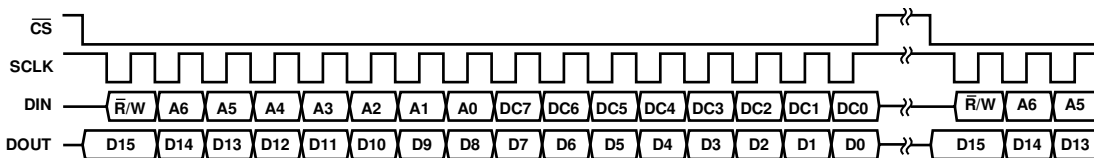

Figure 16. SPI Read Example, Second 16-Bit Sequence



- NOTES
1. DOUT BITS ARE PRODUCED ONLY WHEN THE PREVIOUS 16-BIT DIN SEQUENCE STARTS WITH R/W = 0.
 2. WHEN CS IS HIGH, DOUT IS IN A THREE-STATE, HIGH IMPEDANCE MODE, WHICH ALLOWS MULTIFUNCTIONAL USE OF THE LINE FOR OTHER DEVICES.

Figure 17. SPI Communication Bit Sequence

USER REGISTERS

Table 10. User Register Memory Map (N/A = Not Applicable)

Name	R/W	Flash	PAGE_ID	Address	Default	Register Description	Format
PAGE_ID	R/W	No	0x00	0x00	0x00	Page identifier	N/A
Reserved	N/A	N/A	0x00	0x02 to 0x04	N/A	Reserved	N/A
SEQ_CNT	R	No	0x00	0x06	N/A	Sequence counter	Table 69
SYS_E_FLAG	R	No	0x00	0x08	0x0000	Output, system error flags	Table 60
DIAG_STS	R	No	0x00	0x0A	0x0000	Output, self-test error flags	Table 61
ALM_STS	R	No	0x00	0x0C	0x0000	Output, alarm error flags	Table 62
TEMP_OUT	R	No	0x00	0x0E	N/A	Output, temperature	Table 58
X_GYRO_LOW	R	No	0x00	0x10	N/A	Output, x-axis gyroscope, low word	Table 15
X_GYRO_OUT	R	No	0x00	0x12	N/A	Output, x-axis gyroscope, high word	Table 11
Y_GYRO_LOW	R	No	0x00	0x14	N/A	Output, y-axis gyroscope, low word	Table 16
Y_GYRO_OUT	R	No	0x00	0x16	N/A	Output, y-axis gyroscope, high word	Table 12
Z_GYRO_LOW	R	No	0x00	0x18	N/A	Output, z-axis gyroscope, low word	Table 17
Z_GYRO_OUT	R	No	0x00	0x1A	N/A	Output, z-axis gyroscope, high word	Table 13
X_ACCL_LOW	R	No	0x00	0x1C	N/A	Output, x-axis accelerometer, low word	Table 22
X_ACCL_OUT	R	No	0x00	0x1E	N/A	Output, x-axis accelerometer, high word	Table 18
Y_ACCL_LOW	R	No	0x00	0x20	N/A	Output, y-axis accelerometer, low word	Table 23
Y_ACCL_OUT	R	No	0x00	0x22	N/A	Output, y-axis accelerometer, high word	Table 19
Z_ACCL_LOW	R	No	0x00	0x24	N/A	Output, z-axis accelerometer, low word	Table 24
Z_ACCL_OUT	R	No	0x00	0x26	N/A	Output, z-axis accelerometer, high word	Table 20
X_MAGN_OUT	R	No	0x00	0x28	N/A	Output, x-axis magnetometer, high word	Table 39
Y_MAGN_OUT	R	No	0x00	0x2A	N/A	Output, y-axis magnetometer, high word	Table 40
Z_MAGN_OUT	R	No	0x00	0x2C	N/A	Output, z-axis magnetometer, high word	Table 41
BAROM_LOW	R	No	0x00	0x2E	N/A	Output, barometer, low word	Table 57
BAROM_OUT	R	No	0x00	0x30	N/A	Output, barometer, high word	Table 55
Reserved	N/A	N/A	0x00	0x32 to 0x3E	N/A	Reserved	N/A
X_DELTANG_LOW	R	No	0x00	0x40	N/A	Output, x-axis delta angle, low word	Table 29
X_DELTANG_OUT	R	No	0x00	0x42	N/A	Output, x-axis delta angle, high word	Table 25
Y_DELTANG_LOW	R	No	0x00	0x44	N/A	Output, y-axis delta angle, low word	Table 30
Y_DELTANG_OUT	R	No	0x00	0x46	N/A	Output, y-axis delta angle, high word	Table 26
Z_DELTANG_LOW	R	No	0x00	0x48	N/A	Output, z-axis delta angle, low word	Table 31
Z_DELTANG_OUT	R	No	0x00	0x4A	N/A	Output, z-axis delta angle, high word	Table 27
X_DELTVEL_LOW	R	No	0x00	0x4C	N/A	Output, x-axis delta velocity, low word	Table 36
X_DELTVEL_OUT	R	No	0x00	0x4E	N/A	Output, x-axis delta velocity, high word	Table 32
Y_DELTVEL_LOW	R	No	0x00	0x50	N/A	Output, y-axis delta velocity, low word	Table 37
Y_DELTVEL_OUT	R	No	0x00	0x52	N/A	Output, y-axis delta velocity, high word	Table 33
Z_DELTVEL_LOW	R	No	0x00	0x54	N/A	Output, z-axis delta velocity, low word	Table 38
Z_DELTVEL_OUT	R	No	0x00	0x56	N/A	Output, z-axis delta velocity, high word	Table 34
Reserved	N/A	N/A	0x00	0x58	N/A	Reserved	N/A
Q0_C11_OUT	R/W	Yes	0x00	0x60	N/A	Quaternion, q0 or rotation matrix, C11	Table 43
Q1_C12_OUT	R/W	Yes	0x00	0x62	N/A	Quaternion, q1 or rotation matrix, C12	Table 44
Q2_C13_OUT	R/W	Yes	0x00	0x64	N/A	Quaternion, q2 or rotation matrix, C13	Table 45
Q3_C21_OUT	R/W	Yes	0x00	0x66	N/A	Quaternion, q3 or rotation matrix, C21	Table 46
C22_OUT	R/W	Yes	0x00	0x68	N/A	Rotation matrix, C22	Table 47
ROLL_C23_OUT	R/W	Yes	0x00	0x6A	N/A	Euler angle, roll axis, or rotation matrix, C23	Table 48
PITCH_C31_OUT	R/W	Yes	0x00	0x6C	N/A	Euler angle, pitch axis, or rotation matrix, C31	Table 49
YAW_C32_OUT	R/W	Yes	0x00	0x6E	N/A	Euler angle, yaw axis, or rotation matrix, C32	Table 50
C33_OUT	R/W	Yes	0x00	0x70	N/A	Rotation matrix, C33	Table 51
Reserved	N/A	N/A	0x00	0x72 to 0x76	N/A	Reserved	N/A

Name	R/W	Flash	PAGE_ID	Address	Default	Register Description	Format
TIME_MS_OUT	R	Yes	0x00	0x78	N/A	Factory configuration time: minutes/seconds	Table 157
TIME_DH_OUT	R	Yes	0x00	0x7A	N/A	Factory configuration date/time: day/hour	Table 158
TIME_YM_OUT	R	Yes	0x00	0x7C	N/A	Factory configuration date: year/month	Table 159
PROD_ID	R	Yes	0x00	0x7E	0x4060	Output, product identification (16,480)	Table 66
Reserved	N/A	N/A	0x01	0x00 to 0x7E	N/A	Reserved	N/A
PAGE_ID	R/W	No	0x02	0x00	0x00	Page identifier	N/A
Reserved	N/A	N/A	0x02	0x02	N/A	Reserved	N/A
X_GYRO_SCALE	R/W	Yes	0x02	0x04	0x0000	Calibration, scale, x-axis gyroscope	Table 104
Y_GYRO_SCALE	R/W	Yes	0x02	0x06	0x0000	Calibration, scale, y-axis gyroscope	Table 105
Z_GYRO_SCALE	R/W	Yes	0x02	0x08	0x0000	Calibration, scale, z-axis gyroscope	Table 106
X_ACCL_SCALE	R/W	Yes	0x02	0x0A	0x0000	Calibration, scale, x-axis accelerometer	Table 114
Y_ACCL_SCALE	R/W	Yes	0x02	0x0C	0x0000	Calibration, scale, y-axis accelerometer	Table 115
Z_ACCL_SCALE	R/W	Yes	0x02	0x0E	0x0000	Calibration, scale, z-axis accelerometer	Table 116
XG_BIAS_LOW	R/W	Yes	0x02	0x10	0x0000	Calibration, offset, gyroscope, x-axis, low word	Table 101
XG_BIAS_HIGH	R/W	Yes	0x02	0x12	0x0000	Calibration, offset, gyroscope, x-axis, high word	Table 98
YG_BIAS_LOW	R/W	Yes	0x02	0x14	0x0000	Calibration, offset, gyroscope, y-axis, low word	Table 102
YG_BIAS_HIGH	R/W	Yes	0x02	0x16	0x0000	Calibration, offset, gyroscope, y-axis, high word	Table 99
ZG_BIAS_LOW	R/W	Yes	0x02	0x18	0x0000	Calibration, offset, gyroscope, z-axis, low word	Table 103
ZG_BIAS_HIGH	R/W	Yes	0x02	0x1A	0x0000	Calibration, offset, gyroscope, z-axis, high word	Table 100
XA_BIAS_LOW	R/W	Yes	0x02	0x1C	0x0000	Calibration, offset, accelerometer, x-axis, low word	Table 111
XA_BIAS_HIGH	R/W	Yes	0x02	0x1E	0x0000	Calibration, offset, accelerometer, x-axis, high word	Table 108
YA_BIAS_LOW	R/W	Yes	0x02	0x20	0x0000	Calibration, offset, accelerometer, y-axis, low word	Table 112
YA_BIAS_HIGH	R/W	Yes	0x02	0x22	0x0000	Calibration, offset, accelerometer, y-axis, high word	Table 109
ZA_BIAS_LOW	R/W	Yes	0x02	0x24	0x0000	Calibration, offset, accelerometer, z-axis, low word	Table 113
ZA_BIAS_HIGH	R/W	Yes	0x02	0x26	0x0000	Calibration, offset, accelerometer, z-axis, high word	Table 110
HARD_IRON_X	R/W	Yes	0x02	0x28	0x0000	Calibration, hard iron, magnetometer, x-axis	Table 117
HARD_IRON_Y	R/W	Yes	0x02	0x2A	0x0000	Calibration, hard iron, magnetometer, y-axis	Table 118
HARD_IRON_Z	R/W	Yes	0x02	0x2C	0x0000	Calibration, hard iron, magnetometer, z-axis	Table 119
SOFT_IRON_S11	R/W	Yes	0x02	0x2E	0x0000	Calibration, soft iron, magnetometer, S11	Table 121
SOFT_IRON_S12	R/W	Yes	0x02	0x30	0x0000	Calibration, soft iron, magnetometer, S12	Table 122
SOFT_IRON_S13	R/W	Yes	0x02	0x32	0x0000	Calibration, soft iron, magnetometer, S13	Table 123
SOFT_IRON_S21	R/W	Yes	0x02	0x34	0x0000	Calibration, soft iron, magnetometer, S21	Table 124
SOFT_IRON_S22	R/W	Yes	0x02	0x36	0x0000	Calibration, soft iron, magnetometer, S22	Table 125
SOFT_IRON_S23	R/W	Yes	0x02	0x38	0x0000	Calibration, soft iron, magnetometer, S23	Table 126
SOFT_IRON_S31	R/W	Yes	0x02	0x3A	0x0000	Calibration, soft iron, magnetometer, S31	Table 127
SOFT_IRON_S32	R/W	Yes	0x02	0x3C	0x0000	Calibration, soft iron, magnetometer, S32	Table 128
SOFT_IRON_S33	R/W	Yes	0x02	0x3E	0x0000	Calibration, soft iron, magnetometer, S33	Table 129
BR_BIAS_LOW	R/W	Yes	0x02	0x40	0x0000	Calibration, offset, barometer, low word	Table 132
BR_BIAS_HIGH	R/W	Yes	0x02	0x42	0x0000	Calibration, offset, barometer, high word	Table 131
Reserved	N/A	N/A	0x02	0x44 to 0x60	N/A	Reserved	N/A
REFMTX_R11	R/W	Yes	0x02	0x62	0x7FFF	Reference transformation matrix, R11	Table 85
REFMTX_R12	R/W	Yes	0x02	0x64	0x0000	Reference transformation matrix, R12	Table 86
REFMTX_R13	R/W	Yes	0x02	0x66	0x0000	Reference transformation matrix, R13	Table 87
REFMTX_R21	R/W	Yes	0x02	0x68	0x0000	Reference transformation matrix, R21	Table 88
REFMTX_R22	R/W	Yes	0x02	0x6A	0x7FFF	Reference transformation matrix, R22	Table 89
REFMTX_R23	R/W	Yes	0x02	0x6C	0x0000	Reference transformation matrix, R23	Table 90
REFMTX_R31	R/W	Yes	0x02	0x6E	0x0000	Reference transformation matrix, R31	Table 91
REFMTX_R32	R/W	Yes	0x02	0x70	0x0000	Reference transformation matrix, R32	Table 92
REFMTX_R33	R/W	Yes	0x02	0x72	0x7FFF	Reference transformation matrix, R33	Table 93
USER_SCR_1	R/W	Yes	0x02	0x74	0x0000	User Scratch Register 1	Table 153
USER_SCR_2	R/W	Yes	0x02	0x76	0x0000	User Scratch Register 2	Table 154
USER_SCR_3	R/W	Yes	0x02	0x78	0x0000	User Scratch Register 3	Table 155
USER_SCR_4	R/W	Yes	0x02	0x7A	0x0000	User Scratch Register 4	Table 156

Name	R/W	Flash	PAGE_ID	Address	Default	Register Description	Format
FLSHCNT_LOW	R	Yes	0x02	0x7C	N/A	Diagnostic, flash memory count, low word	Table 148
FLSHCNT_HIGH	R	Yes	0x02	0x7E	N/A	Diagnostic, flash memory count, high word	Table 149
PAGE_ID	R/W	No	0x03	0x00	0x0000	Page identifier	N/A
GLOB_CMD	W	No	0x03	0x02	N/A	Control, global commands	Table 147
Reserved	N/A	N/A	0x03	0x04	N/A	Reserved	N/A
FNCTIO_CTRL	R/W	Yes	0x03	0x06	0x000D	Control, I/O pins, functional definitions	Table 150
GPIO_CTRL	R/W	Yes	0x03	0x08	0x00X0 ¹	Control, I/O pins, general purpose	Table 151
CONFIG	R/W	Yes	0x03	0x0A	0x00C0	Control, clock, and miscellaneous correction	Table 107
DEC_RATE	R/W	Yes	0x03	0x0C	0x0000	Control, output sample rate decimation	Table 68
Reserved	N/A	N/A	0x03	0x0E	N/A	Reserved	N/A
SLP_CNT	R/W	No	0x03	0x10	N/A	Control, power-down/sleep mode	Table 152
Reserved	N/A	N/A	0x03	0x12 to 0x14	N/A	Reserved	N/A
FILTR_BNK_0	R/W	Yes	0x03	0x16	0x0000	Filter selection	Table 70
FILTR_BNK_1	R/W	Yes	0x03	0x18	0x0000	Filter selection	Table 71
Reserved	N/A	N/A	0x03	0x1A to 0x1E	N/A	Reserved	N/A
ALM_CNFG_0	R/W	Yes	0x03	0x20	0x0000	Alarm configuration	Table 143
ALM_CNFG_1	R/W	Yes	0x03	0x22	0x0000	Alarm configuration	Table 144
ALM_CNFG_2	R/W	Yes	0x03	0x24	0x0000	Alarm configuration	Table 145
Reserved	N/A	N/A	0x03	0x26	N/A	Reserved	N/A
XG_ALM_MAGN	R/W	Yes	0x03	0x28	0x0000	Alarm, x-axis gyroscope threshold setting	Table 133
YG_ALM_MAGN	R/W	Yes	0x03	0x2A	0x0000	Alarm, y-axis gyroscope threshold setting	Table 134
ZG_ALM_MAGN	R/W	Yes	0x03	0x2C	0x0000	Alarm, z-axis gyroscope threshold setting	Table 135
XA_ALM_MAGN	R/W	Yes	0x03	0x2E	0x0000	Alarm, x-axis accelerometer threshold	Table 136
YA_ALM_MAGN	R/W	Yes	0x03	0x30	0x0000	Alarm, y-axis accelerometer threshold	Table 137
ZA_ALM_MAGN	R/W	Yes	0x03	0x32	0x0000	Alarm, z-axis accelerometer threshold	Table 138
XM_ALM_MAGN	R/W	Yes	0x03	0x34	0x0000	Alarm, x-axis magnetometer threshold	Table 139
YM_ALM_MAGN	R/W	Yes	0x03	0x36	0x0000	Alarm, y-axis magnetometer threshold	Table 140
ZM_ALM_MAGN	R/W	Yes	0x03	0x38	0x0000	Alarm, z-axis magnetometer threshold	Table 141
BR_ALM_MAGN	R/W	Yes	0x03	0x3A	0x0000	Alarm, barometer threshold setting	Table 142
Reserved	N/A	N/A	0x03	0x3C to 0x4E	N/A	Reserved	N/A
EKF_CNFG	R/W	Yes	0x03	0x50	0x0200	Extended Kalman filter configuration	Table 95
Reserved	N/A	N/A	0x03	0x52	N/A	Reserved	N/A
DECLN_ANGL	R/W	Yes	0x03	0x54	0x0000	Declination angle	Table 94
ACC_DISTB_THR	R/W	Yes	0x03	0x56	0x0020	Accelerometer disturbance threshold	Table 96
MAG_DISTB_THR	R/W	Yes	0x03	0x58	0x0030	Magnetometer disturbance threshold	Table 97
Reserved	N/A	N/A	0x03	0x5A to 0x5E	N/A	Reserved	N/A
QCVR_NOIS_LWR	R/W	Yes	0x03	0x60	0xC5AC	Process covariance, gyroscope noise, lower word	Table 78
QCVR_NOIS_UPR	R/W	Yes	0x03	0x62	0x3727	Process covariance, gyroscope noise, upper word	Table 77
QCVR_RRW_LWR	R/W	Yes	0x03	0x64	0xE6FF	Process covariance, gyroscope RRW, lower word	Table 80
QCVR_RRW_UPR	R/W	Yes	0x03	0x66	0x2E5B	Process covariance, gyroscope RRW, upper word	Table 79
Reserved	N/A	N/A	0x03	0x68 to 0x6A	N/A	Reserved	N/A
RCVR_ACC_LWR	R/W	Yes	0x03	0x6C	0x705F	Measurement covariance, accelerometer, upper	Table 82
RCVR_ACC_UPR	R/W	Yes	0x03	0x6E	0x3189	Measurement covariance, accelerometer, lower	Table 81
RCVR_MAG_LWR	R/W	Yes	0x03	0x70	0xCC77	Measurement covariance, magnetometer, upper	Table 84
RCVR_MAG_UPR	R/W	Yes	0x03	0x72	0x32AB	Measurement covariance, magnetometer, lower	Table 83
Reserved	N/A	N/A	0x03	0x74 to 0x76	N/A	Reserved	N/A
FIRM_REV	R	Yes	0x03	0x78	N/A	Firmware revision	Table 63
FIRM_DM	R	Yes	0x03	0x7A	N/A	Firmware programming date: day/month	Table 64
FIRM_Y	R	Yes	0x03	0x7C	N/A	Firmware programming date: year	Table 65
Reserved	N/A	N/A	0x03	0x7E	N/A	Reserved	N/A
Reserved	N/A	N/A	0x04	0x00 to 0x18	N/A	Reserved	N/A
SERIAL_NUM	R	Yes	0x04	0x20	N/A	Serial number	Table 67
Reserved	N/A	N/A	0x04	0x22 to 0x7F	N/A	Reserved	N/A

Name	R/W	Flash	PAGE_ID	Address	Default	Register Description	Format
PAGE_ID	R/W	No	0x05	0x00	0x0000	Page identifier	N/A
FIR_COEF_Axxx	R/W	Yes	0x05	0x02 to 0x7E	N/A	FIR Filter Bank A, Coefficients 0 through 119	Table 72
PAGE_ID	R/W	No	0x06	0x00	0x0000	Page identifier	N/A
FIR_COEF_Axxx	R/W	Yes	0x06	0x02 to 0x7E	N/A	FIR Filter Bank A, Coefficients 60 through 119	Table 72
PAGE_ID	R/W	No	0x07	0x00	0x0000	Page identifier	N/A
FIR_COEF_Bxxx	R/W	Yes	0x07	0x02 to 0x7E	N/A	FIR Filter Bank B, Coefficients 0 through 119	Table 73
PAGE_ID	R/W	No	0x08	0x00	0x0000	Page identifier	N/A
FIR_COEF_Bxxx	R/W	Yes	0x08	0x02 to 0x7E	N/A	FIR Filter Bank B, Coefficients 60 through 119	Table 73
PAGE_ID	R/W	No	0x09	0x00	0x0000	Page identifier	N/A
FIR_COEF_Cxxx	R/W	Yes	0x09	0x02 to 0x7E	N/A	FIR Filter Bank C, Coefficients 0 through 119	Table 74
PAGE_ID	R/W	No	0x0A	0x00	0x0000	Page identifier	N/A
FIR_COEF_Cxxx	R/W	Yes	0x0A	0x02 to 0x7E	N/A	FIR Filter Bank C, Coefficients 60 through 119	Table 74
PAGE_ID	R/W	No	0x0B	0x00	0x0000	Page identifier	N/A
FIR_COEF_Dxxx	R/W	Yes	0x0B	0x02 to 0x7E	N/A	FIR Filter Bank D, Coefficients 0 through 119	Table 75
PAGE_ID	R/W	No	0x0C	0x00	0x0000	Page identifier	N/A
FIR_COEF_Dxxx	R/W	Yes	0x0C	0x02 to 0x7E	N/A	FIR Filter Bank D, Coefficients 60 through 119	Table 75

¹ The GPIO_CTRL[7:4] bits reflect the logic levels on the DIOx lines and do not have a default setting.

OUTPUT DATA REGISTERS

After the ADIS16480 completes its start-up process, the PAGE_ID register contains 0x0000, which sets Page 0 as the active page for SPI access. Page 0 contains the output data, real-time clock, status, and product identification registers.

INERTIAL SENSOR DATA FORMAT

The gyroscope, accelerometer, delta angle, delta velocity, and barometer output data registers use a 32-bit, twos complement format. Each output uses two registers to support this resolution. Figure 18 provides an example of how each register contributes to each inertial measurement. In this case, X_GYRO_OUT is the most significant word (upper 16 bits), and X_GYRO_LOW is the least significant word (lower 16 bits), which captures the bit growth associated with the final averaging/decimation register. When using the maximum sample rate (DEC_RATE = 0x0000), the x_xxxx_LOW registers are not active.

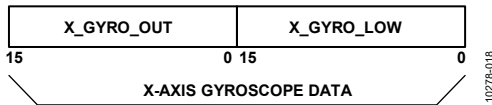

Figure 18. Gyroscope Output Format Example, DEC_RATE > 0

The arrows in Figure 19 describe the direction of the motion, which produces a positive output response in each sensor output register. The accelerometers respond to both dynamic and static forces associated with acceleration, including gravity. When lying perfectly flat, as shown in Figure 19, the z-axis accelerometer output is 1 g, and the x and y accelerometers are 0 g. EKF_CNFG[3] (see Table 95) provides a selection for gyroscope, accelerometer, and magnetometer data orientation, between the body frame and the local navigation frame. When EKF_CNFG[3] = 0 (default), the accelerometer and magnetometer data displays in the local navigation frame.

ROTATION RATE (GYROSCOPE)

The registers that use the x_GYRO_OUT format are the primary registers for the gyroscope measurements (see Table 11, Table 12, and Table 13). When processing data from these registers, use a 16-bit, twos complement data format. Table 14 provides x_GYRO_OUT digital coding examples.

Table 11. X_GYRO_OUT (Page 0, Base Address = 0x12)

Bits	Description
[15:0]	X-axis gyroscope data; twos complement, $\pm 450^\circ/\text{sec}$ range, $0^\circ/\text{sec} = 0x0000$, 1 LSB = $0.02^\circ/\text{sec}$

Table 12. Y_GYRO_OUT (Page 0, Base Address = 0x16)

Bits	Description
[15:0]	Y-axis gyroscope data; twos complement, $\pm 450^\circ/\text{sec}$ range, $0^\circ/\text{sec} = 0x0000$, 1 LSB = $0.02^\circ/\text{sec}$

Table 13. Z_GYRO_OUT (Page 0, Base Address = 0x1A)

Bits	Description
[15:0]	Z-axis gyroscope data; twos complement, $\pm 450^\circ/\text{sec}$ range, $0^\circ/\text{sec} = 0x0000$, 1 LSB = $0.02^\circ/\text{sec}$

Table 14. X_GYRO_OUT Data Format Examples

Rotation Rate	Decimal	Hex	Binary
+450°/sec	+22,500	0x57E4	0101 0111 1110 0100
+0.04°/sec	+2	0x0002	0000 0000 0000 0010
+0.02°/sec	+1	0x0001	0000 0000 0000 0001
0°/sec	0	0x0000	0000 0000 0000 0000
-0.02°/sec	-1	0xFFFF	1111 1111 1111 1111
-0.04°/sec	-2	0xFFFE	1111 1111 1111 1110
-450°/sec	-22,500	0xA81C	1010 1000 0001 1100

The MSB in x_GYRO_LOW has a weight of $0.01^\circ/\text{sec}$, and each subsequent bit has $\frac{1}{2}$ the weight of the previous one.

Table 15. X_GYRO_LOW (Page 0, Base Address = 0x10)

Bits	Description
[15:0]	X-axis gyroscope data; additional resolution bits

Table 16. Y_GYRO_LOW (Page 0, Base Address = 0x14)

Bits	Description
[15:0]	Y-axis gyroscope data; additional resolution bits

Table 17. Z_GYRO_LOW (Page 0, Base Address = 0x18)

Bits	Description
[15:0]	Z-axis gyroscope data; additional resolution bits

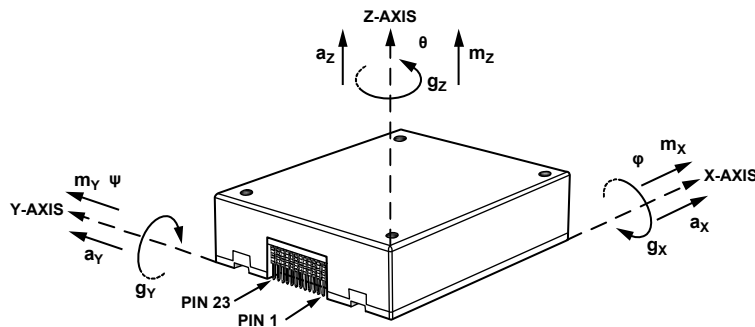

Figure 19. Inertial Sensor Direction Reference Diagram

ACCELERATION

The registers that use the `x_ACCL_OUT` format are the primary registers for the accelerometer measurements (see Table 18, Table 19, and Table 20). When processing data from these registers, use a 16-bit, twos complement data format. Table 21 provides `x_ACCL_OUT` digital coding examples.

Table 18. X_ACCL_OUT (Page 0, Base Address = 0x1E)

Bits	Description
[15:0]	X-axis accelerometer data; twos complement, $\pm 10\text{ g}$ range, $0\text{ g} = 0x0000$, 1 LSB = 0.8 mg

Table 19. Y_ACCL_OUT (Page 0, Base Address = 0x22)

Bits	Description
[15:0]	Y-axis accelerometer data; twos complement, $\pm 10\text{ g}$ range, $0\text{ g} = 0x0000$, 1 LSB = 0.8 mg

Table 20. Z_ACCL_OUT (Page 0, Base Address = 0x26)

Bits	Description
[15:0]	Z-axis accelerometer data; twos complement, $\pm 10\text{ g}$ range, $0\text{ g} = 0x0000$, 1 LSB = 0.8 mg

Table 21. x_ACCL_OUT Data Format Examples

Acceleration	Decimal	Hex	Binary
+10 g	+12,500	0x30D4	0011 0000 1101 0100
+1.6 mg	+2	0x0002	0000 0000 0000 0010
+0.8 mg	+1	0x0001	0000 0000 0000 0001
0 mg	0	0x0000	0000 0000 0000 0000
-0.8 mg	-1	0xFFFF	1111 1111 1111 1111
-1.6 mg	-2	0xFFFE	1111 1111 1111 1110
-10 g	-12,500	0xCF2C	1100 1111 0010 1100

The MSB in `x_ACCL_LOW` has a weight of 0.4 mg, and each subsequent bit has $\frac{1}{2}$ the weight of the previous one.

Table 22. X_ACCL_LOW (Page 0, Base Address = 0x1C)

Bits	Description
[15:0]	X-axis accelerometer data; additional resolution bits

Table 23. Y_ACCL_LOW (Page 0, Base Address = 0x20)

Bits	Description
[15:0]	Y-axis accelerometer data; additional resolution bits

Table 24. Z_ACCL_LOW (Page 0, Base Address = 0x24)

Bits	Description
[15:0]	Z-axis accelerometer data; additional resolution bits

DELTA ANGLES

The `x_DELTANG_OUT` registers are the primary output registers for the delta angle calculations. When processing data from these registers, use a 16-bit, twos complement data format (see Table 25, Table 26, and Table 27). Table 28 provides `x_DELTANG_OUT` digital coding examples.

The delta angle outputs represent an integration of the gyroscope measurements and use the following formula for all three axes (x-axis displayed):

$$\Delta\theta_{x,nD} = \frac{1}{2f_s} \times \sum_{d=0}^{D-1} (\omega_{x,nD+d} + \omega_{x,nD+d-1})$$

where:

ω_x is the x-axis rate of rotation (gyroscope).

f_s is the sample rate.

n is the sample time prior to the decimation filter.

D is the decimation rate (DEC_RATE + 1).

When using the internal sample clock, f_s is equal to 2,460 SPS. When using the external clock option, f_s is equal to the frequency of the external clock, which is limited to a minimum of 2 kHz, in order to prevent overflow in the `x_DELTANG_xxx` registers at high rotation rates. See Table 68 and Figure 20 for more information on the DEC_RATE register (decimation filter).

Table 25. X_DELTANG_OUT (Page 0, Base Address = 0x42)

Bits	Description
[15:0]	X-axis delta angle data; twos complement, $\pm 720^\circ$ range, $0^\circ = 0x0000$, 1 LSB = $720^\circ/2^{15} = \sim 0.022^\circ$

Table 26. Y_DELTANG_OUT (Page 0, Base Address = 0x46)

Bits	Description
[15:0]	Y-axis delta angle data; twos complement, $\pm 720^\circ$ range, $0^\circ = 0x0000$, 1 LSB = $720^\circ/2^{15} = \sim 0.022^\circ$

Table 27. Z_DELTANG_OUT (Page 0, Base Address = 0x4A)

Bits	Description
[15:0]	Z-axis delta angle data; twos complement, $\pm 720^\circ$ range, $0^\circ = 0x0000$, 1 LSB = $720^\circ/2^{15} = \sim 0.022^\circ$

Table 28. x_DELTANG_OUT Data Format Examples

Angle (°)	Decimal	Hex	Binary
$+720 \times (2^{15} - 1)/2^{15}$	+32,767	0x7FFF	0111 1111 1111 1111
$+1440/2^{15}$	+2	0x0002	0000 0000 0000 0010
$+720/2^{15}$	+1	0x0001	0000 0000 0000 0001
0	0	0x0000	0000 0000 0000 0000
$-720/2^{15}$	-1	0xFFFF	1111 1111 1111 1111
$-1440/2^{15}$	-2	0xFFFE	1111 1111 1111 1110
-720	-32,768	0x8000	1000 0000 0000 0000

The x_DELTANG_LOW registers (see Table 29, Table 30, and Table 31) provide additional resolution bits for the delta angle and combine with the x_DELTANG_OUT registers to provide a 32-bit, twos complement number. The MSBs in the x_DELTANG_LOW registers have a weight of ~0.011° (720°/2¹⁶), and each subsequent bit carries a weight of ½ of the previous one.

Table 29. X_DELTANG_LOW (Page 0, Base Address = 0x40)

Bits	Description
[15:0]	X-axis delta angle data; additional resolution bits

Table 30. Y_DELTANG_LOW (Page 0, Base Address = 0x44)

Bits	Description
[15:0]	Y-axis delta angle data; additional resolution bits

Table 31. Z_DELTANG_LOW (Page 0, Base Address = 0x48)

Bits	Description
[15:0]	Z-axis delta angle data; additional resolution bits

DELTA VELOCITY

The registers that use the x_DELTVEL_OUT format are the primary registers for the delta velocity calculations. When processing data from these registers, use a 16-bit, twos complement data format (see Table 32, Table 33, and Table 34). Table 35 provides x_DELTVEL_OUT digital coding examples.

The delta velocity outputs represent an integration of the accelerometer measurements and use the following formula for all three axes (x-axis displayed):

$$\Delta V_{x,nD} = \frac{1}{2f_s} \times \sum_{d=0}^{D-1} (a_{x,nD+d} + a_{x,nD+d-1})$$

where:

a_x is the x-axis linear acceleration.

f_s is the sample rate.

n is the sample time prior to the decimation filter.

D is the decimation rate (DEC_RATE + 1).

When using the internal sample clock, f_s is equal to 2,460 SPS. When using the external clock option, f_s is equal to the frequency of the external clock, which is limited to a minimum of 2 kHz, in order to prevent overflow in the x_DELTVEL_xxx registers at high rotation rates. See Table 68 and Figure 20 for more information on the DEC_RATE register (decimation filter).

Table 32. X_DELTVEL_OUT (Page 0, Base Address = 0x4E)

Bits	Description
[15:0]	X-axis delta velocity data; twos complement, ±200 m/sec range, 0 m/sec = 0x0000 1 LSB = 200 m/sec ÷ (2 ¹⁵ - 1) = ~6.104 mm/sec

Table 33. Y_DELTVEL_OUT (Page 0, Base Address = 0x52)

Bits	Description
[15:0]	Y-axis delta velocity data; twos complement, ±200 m/sec range, 0 m/sec = 0x0000 1 LSB = 200 m/sec ÷ (2 ¹⁵ - 1) = ~6.104 mm/sec

Table 34. Z_DELTVEL_OUT (Page 0, Base Address = 0x56)

Bits	Description
[15:0]	Z-axis delta velocity data; twos complement, ±200 m/sec range, 0 m/sec = 0x0000 1 LSB = 200 m/sec ÷ (2 ¹⁵ - 1) = ~6.104 mm/sec

Table 35. x_DELTVEL_OUT, Data Format Examples

Velocity (m/sec)	Decimal	Hex	Binary
+200 × (2 ¹⁵ - 1)/2 ¹⁵	+32,767	0x7FFF	0111 1111 1111 1111
+400/2 ¹⁵	+2	0x0002	0000 0000 0000 0010
+200/2 ¹⁵	+1	0x0001	0000 0000 0000 0001
0	0	0x0000	0000 0000 0000 0000
-200/2 ¹⁵	-1	0xFFFF	1111 1111 1111 1111
-400/2 ¹⁵	-2	0xFFFE	1111 1111 1111 1110
-200	-32,768	0x8000	1000 0000 0000 0000

The x_DELTVEL_LOW registers (see Table 36, Table 37, and Table 38) provide additional resolution bits for the delta velocity and combine with the x_DELTVEL_OUT registers to provide a 32-bit, twos complement number. The MSBs in the x_DELTVEL_LOW registers have a weight of ~3.052 mm/sec (200 m/sec ÷ 2¹⁶), and each subsequent bit carries a weight of ½ of the previous one.

Table 36. X_DELTVEL_LOW (Page 0, Base Address = 0x4C)

Bits	Description
[15:0]	X-axis delta velocity data; additional resolution bits

Table 37. Y_DELTVEL_LOW (Page 0, Base Address = 0x50)

Bits	Description
[15:0]	Y-axis delta velocity data; additional resolution bits

Table 38. Z_DELTVEL_LOW (Page 0, Base Address = 0x54)

Bits	Description
[15:0]	Z-axis delta velocity data; additional resolution bits

MAGNETOMETERS

The registers that use the `x_MAGN_OUT` format are the primary registers for the magnetometer measurements. When processing data from these registers, use a 16-bit, twos complement data format. Table 39, Table 40, and Table 41 provide each register numerical format, and Table 42 provides `x_MAGN_OUT` digital coding examples.

Table 39. X_MAGN_OUT (Page 0, Base Address = 0x28)

Bits	Description
[15:0]	X-axis magnetometer data; twos complement, ± 3.2767 gauss range, 0 gauss = 0x0000, 1 LSB = 0.1 mgauss

Table 40. Y_MAGN_OUT (Page 0, Base Address = 0x2A)

Bits	Description
[15:0]	Y-axis magnetometer data; twos complement, ± 3.2767 gauss range, 0 gauss = 0x0000, 1 LSB = 0.1 mgauss

Table 41. Z_MAGN_OUT (Page 0, Base Address = 0x2C)

Bits	Description
[15:0]	Z-axis magnetometer data; twos complement, ± 3.2767 gauss range, 0 gauss = 0x0000, 1 LSB = 0.1 mgauss

Table 42. x_MAGN_OUT Data Format Examples

Magnetic Field	Decimal	Hex	Binary
+3.2767 gauss	+32,767	0x7FFF	0111 1111 1111 1111
+0.2 mgauss	+2	0x0002	0000 0000 0000 0010
+0.1 mgauss	+1	0x0001	0000 0000 0000 0001
0 gauss	0	0x0000	0000 0000 0000 0000
-0.1 mgauss	-1	0xFFFF	1111 1111 1111 1111
-0.2 mgauss	-2	0xFFFE	1111 1111 1111 1110
-3.2768 gauss	-32,768	0x8000	1000 0000 0000 0000

ROLL, PITCH, YAW ANGLES

The `EKF_CNFG` (Table 95) register contains two bits, which define the output format of the angle estimates. The first one is `EKF_CNFG[4]`, which selects the output format. When `EKF_CNFG[4] = 0`, the output data is in the format of a quaternion vector (see Table 43 through Table 46) and Euler angles (see Table 48 through Table 50). When `EKF_CNFG[4] = 1`, the output data is in the form of a rotation matrix (see Table 43 through Table 51).

INITIAL CONDITIONS

During start-up, reset recovery, sleep mode recovery, and power-down recovery, the [ADIS16480](#) uses the inertial sensor outputs to estimate bias and a number of critical initial states that are critical for stable operation and accurate angle estimates. To assure convergence and accuracy, only initiate start-up or reset commands when the platform of the [ADIS16480](#) is not in motion and the magnetic environment is free of interference.

Quaternion

This four-element hypercomplex number defines the attitude of the body frame, relative to that of the navigation frame. The `Qx_Cxx_OUT` registers (See Table 43 through Table 46) contain the value for each element (q_0, q_1, q_2, q_4). The element, q_0 , is the scalar part of the quaternion and represents the magnitude of the rotation. The vector portion of the quaternion is defined by $(q_1, q_2, q_3)^T$, which identifies the axis about which the rotation takes place, in adjusting the body frame to that of the navigation frame. When the orientation is in its reference position, q_0 is equal to one and q_1, q_2 , and q_3 are equal to zero. These registers update at the same data rate as the gyroscopes and accelerometers.

Euler Angles

The Euler angle names are yaw (ψ), pitch (θ), and roll (ϕ). See Figure 19 for the axial association of these angles. These three elements represent the most intuitive way of describing orientation angles. The process of translating body frame data to the navigation frame can be broken down into three successive translations. These translations follow as the yaw rotation about the z-axis, followed by the pitch rotation about the y-axis, and finally the roll rotation about the x-axis. Reverse this sequence to resolve a reverse rotation. Difficulties in this process arise due to the singularities that occur whenever the pitch approaches $\pm 90^\circ$ thus making the roll indistinguishable from the yaw. For applications that may approach these limits, the quaternion or rotation matrix output may be more appropriate. When the [ADIS16480](#) is in its reference position, all three Euler angles are equal to zero. The update rate for these variables is the same as the gyroscopes and accelerometers.

ROTATION MATRIX DATA

The rotation matrix defines the attitude of the body frame relative to that of the navigation frame. The Cxx_OUT registers (see Table 43 through Table 51) define each element in this 3 × 3 matrix. Each element is the product of the unit vectors that describe the axes of the two frames, which in turn, are equal to the cosines of the angles between the axes. When the ADIS16480 is in its reference position, the rotation matrix are equal to a 3 × 3 identify matrix.

Table 43. Q0_C11_OUT (Page 0, Base Address = 0x60)

Bits	Description
[15:0]	Quarterion scalar, q0 or rotation matrix, C11 Twos complement q0 scale factor = 0.000030518/LSB (1/2 ¹⁵) C11 scale factor = 0.000030518/LSB (1/2 ¹⁵)

Table 44. Q1_C12_OUT (Page 0, Base Address = 0x62)

Bits	Description
[15:0]	Quarterion vector, q1; or rotation matrix, C12 Twos complement q1 scale factor = 0.000030518/LSB (1/2 ¹⁵) C12 scale factor = 0.000030518/LSB (1/2 ¹⁵)

Table 45. Q2_C13_OUT (Page 0, Base Address = 0x64)

Bits	Description
[15:0]	Quarterion vector, q2; or rotation matrix, C13 Twos complement q2 scale factor = 0.000030518/LSB (1/2 ¹⁵) C13 scale factor = 0.000030518/LSB (1/2 ¹⁵)

Table 46. Q3_C21_OUT (Page 0, Base Address = 0x66)

Bits	Description
[15:0]	Quarterion vector, q3; or rotation matrix, C21 Twos complement q3 scale factor = 0.000030518/LSB (1/2 ¹⁵) C21 scale factor = 0.000030518/LSB (1/2 ¹⁵)

Table 47. C22_OUT (Page 0, Base Address = 0x68)

Bits	Description
[15:0]	Rotation matrix, C22, twos complement C22 scale factor = 0.000030518/LSB (1/2 ¹⁵)

Table 48. ROLL_C23_OUT (Page 0, Base Address = 0x6A)

Bits	Description
[15:0]	Euler angle, φ, roll or rotation matrix, C23 Twos complement, range: ±180° (±π radians) Roll angle scale factor = (180/2 ¹⁵)°/LSB Rotation matrix variable, C23 Twos complement C23 scale factor = 0.000030518/LSB (1/2 ¹⁵)

Table 49. PITCH_C31_OUT (Page 0, Base Address = 0x6C)

Bits	Description
[15:0]	Euler angle, θ, pitch or rotation matrix, C31 Twos complement, range: ±90° (±π/2 radians) Pitch angle scale factor = (180/2 ¹⁵)°/LSB Rotation matrix variable, C31 Twos complement, 0.000030518/LSB (1/2 ¹⁵)

Table 50. YAW_C32_OUT (Page 0, Base Address = 0x6E)

Bits	Description
[15:0]	Euler angle, Ψ, yaw or rotation matrix, C32 Twos complement, range: ±180° (±π radians) Yaw angle scale factor = (180/2 ¹⁵)°/LSB Rotation matrix variable, C32 Twos complement, 0.000030518/LSB (1/2 ¹⁵)

Table 51. C33_OUT (Page 0, Base Address = 0x70)

Bits	Description
[15:0]	Rotation matrix, C33, twos complement C22 scale factor = 0.000030518/LSB (1/2 ¹⁵)

Table 52. Rotation Matrix/q1/q2/q3 Data Format Examples

Angle (°)	Decimal	Hex	Binary
(2 ¹⁵ - 1)/2 ¹⁵	+32,767	0x7FFF	0111 1111 1111 1111
2/2 ¹⁵	+2	0x0002	0000 0000 0000 0010
1/2 ¹⁵	+1	0x0001	0000 0000 0000 0001
0	0	0x0000	0000 0000 0000 0000
-1/2 ¹⁵	-1	0xFFFF	1111 1111 1111 1111
-2/2 ¹⁵	-2	0xFFFE	1111 1111 1111 1110
-1	-32,768	0x8000	1000 0000 0000 0000

Table 53. Yaw, Roll, q0 Angle Data Format Examples

Angle (°)	Decimal	Hex	Binary
+180 × (2 ¹⁵ - 1)/2 ¹⁵	+32,767	0x7FFF	0111 1111 1111 1111
+360/2 ¹⁵	+2	0x0002	0000 0000 0000 0010
+180/2 ¹⁵	+1	0x0001	0000 0000 0000 0001
0	0	0x0000	0000 0000 0000 0000
-180/2 ¹⁵	-1	0xFFFF	1111 1111 1111 1111
-360/2 ¹⁵	-2	0xFFFE	1111 1111 1111 1110
-180	-32,768	0x8000	1000 0000 0000 0000

Table 54. Pitch Angle Data Format Examples

Angle (°)	Decimal	Hex	Binary
+90 × (2 ¹⁵ - 1)/2 ¹⁵	+16,383	0x3FFF	0011 1111 1110 1111
+360/2 ¹⁵	+2	0x0002	0000 0000 0000 0010
+180/2 ¹⁵	+1	0x0001	0000 0000 0000 0001
0	0	0x0000	0000 0000 0000 0000
-180/2 ¹⁵	-1	0xFFFF	1111 1111 1111 1111
-360/2 ¹⁵	-2	0xFFFE	1111 1111 1111 1110
-90	-16,384	0xC000	1100 0000 0000 0000

BAROMETER

The BAROM_OUT register (see Table 55) and BAROM_LOW register (see Table 57) provide access to the barometric pressure data. These two registers combine to provide a 32-bit, twos complement format. Some applications are able to use BAROM_OUT by itself. For cases where the finer resolution available from BAROM_LOW is valuable, combine them in the same manner as the gyroscopes (see Figure 18). When processing data from the BAROM_OUT register alone, use a 16-bit, twos complement data format. Table 55 provides the numerical format in BAROM_OUT, and Table 56 provides digital coding examples.

Table 55. BAROM_OUT (Page 0, Base Address = 0x30)

Bits	Description
[15:0]	Barometric pressure; twos complement, ±1.31 bar range, 0 bar = 0x0000, 40 µbar/LSB

Table 56. BAROM_OUT Data Format Examples

Pressure (bar)	Decimal	Hex	Binary
+0.00004 × (2 ¹⁵ – 1)	+32,767	0x7FFF	0111 1111 1111 1111
+0.00008	+2	0x0002	0000 0000 0000 0010
+0.00004	+1	0x0001	0000 0000 0000 0001
0	0	0x0000	0000 0000 0000 0000
–0.00004	–1	0xFFFF	1111 1111 1111 1111
–0.00008	–2	0xFFFE	1111 1111 1111 1110
–0.00004 × 2 ¹⁵	–32,768	0x8000	1000 0000 0000 0000

The BAROM_LOW register provides additional resolution for the barometric pressure measurement. The MSB has a weight of 20 µbar, and each subsequent bit carries a weight of ½ of the previous one.

Table 57. BAROM_LOW (Page 0, Base Address = 0x2E)

Bits	Description
[15:0]	Barometric pressure; additional resolution bits

INTERNAL TEMPERATURE

The TEMP_OUT register provides an internal temperature measurement that can be useful for observing relative temperature changes inside of the ADIS16480 (see Table 58). Table 59 provides TEMP_OUT digital coding examples. Note that this temperature reflects a higher temperature than ambient, due to self heating.

Table 58. TEMP_OUT (Page 0, Base Address = 0x0E)

Bits	Description
[15:0]	Temperature data; twos complement, 0.00565°C per LSB, 25°C = 0x0000

Table 59. TEMP_OUT Data Format Examples

Temperature (°C)	Decimal	Hex	Binary
+85	+10,619	0x297B	0010 1001 0111 1011
+25 + 0.0113	+2	0x0002	0000 0000 0000 0010
+25 + 0.00565	+1	0x0001	0000 0000 0000 0001
+25	0	0x0000	0000 0000 0000 0000
+25 – 0.00565	–1	0xFFFF	1111 1111 1111 1111
+25 – 0.0113	–2	0xFFFE	1111 1111 1111 1110
–40	–11,504	0xD310	1101 0011 0001 0000

STATUS/ALARM INDICATORS

The SYS_E_FLAG register in Table 60 provides the system error flags and new data bits for the magnetometer and barometer outputs. The new data flags are useful for triggering data collection of the magnetometer and barometer (x_MAGN_OUT and BAROM_XXX registers) because they update at a fixed rate that is not dependent on the DEC_RATE setting. Reading the SYS_E_FLAG register clears all of its error flags and returns each bit to a zero value, with the exception of Bit[7]. If SYS_E_FLAG[7] is high, use the software reset (GLOB_CMD[7], see Table 147) to clear this condition and restore normal operation. If any bit in the SYS_E_FLAG register is associated an error condition that remains after reading this register, this bit automatically returns to an alarm value of 1.

Table 60. SYS_E_FLAG (Page 0, Base Address = 0x08)

Bits	Description (Default = 0x0000)
15	Watch dog timer flag (1 = timed out)
14	Not used
13	EKF divergence (1 = divergence has occurred)
12	Gyroscope saturation 1 = saturation conditions exists and the gyroscope weighting factors in the EKF have been automatically reduced 0 = gyroscope measurements within range
11	Magnetometer disturbance 1 = magnetometer measurements exceed MAG_DISTB_THR levels (see Table 97) and the magnetometer influence in the EKF has been automatically eliminated 0 = magnetometer measurements are within the specified normal range
10	Linear acceleration 1 = accelerometer measurements exceed ACC_DISTR_THR levels (see Table 96) and the accelerometer weighting factors in the EKF have been automatically reduced 0 = accelerometer measurements are within the specified normal range
9	New data flag, barometer (1 = new, unread data) ¹
8	New data flag, magnetometer (1 = new, unread data) ²
7	Processing overrun (1 = error)
6	Flash memory update, result of GLOB_CMD[3] = 1 (1 = failed update, 0 = update successful)
5	Inertial self-test failure (1 = DIAG_STS ≠ 0x0000)
4	Sensor overrange (1 = at least one sensor overranged)
3	SPI communication error (1 = error condition, when the number of SCLK pulses is not equal to a multiple of 16)
[2:1]	Not used
0	Alarm status flag (1 = ALM_STS ≠ 0x0000)

¹ This flag restores to zero after reading the contents on BAROM_OUT.

² This flag restores to zero after reading one x_MAGN_OUT register.

The DIAG_STS register in Table 61 provides the flags for the internal self-test function, which is from GLOB_CMD[1] (see Table 147). Note that the barometer flag, DIAG_STS[11], only updates after start-up and reset operations and that reading DIAG_STS also resets it to 0x0000.

Table 61. DIAG_STS (Page 0, Base Address = 0x0A)

Bits	Description (Default = 0x0000)
[15:12]	Not used
11	Self-test failure, barometer (1 = failed at startup)
10	Self-test failure, z-axis magnetometer (1 = failure)
9	Self-test failure, y-axis magnetometer (1 = failure)
8	Self-test failure, x-axis magnetometer (1 = failure)
[7:6]	Not used
5	Self-test failure, z-axis accelerometer (1 = failure)
4	Self-test failure, y-axis accelerometer (1 = failure)
3	Self-test failure, x-axis accelerometer (1 = failure)
2	Self-test failure, z-axis gyroscope (1 = failure)
1	Self-test failure, y-axis gyroscope (1 = failure)
0	Self-test failure, x-axis gyroscope (1 = failure)

The ALM_STS register in Table 62 provides the alarm bits for the programmable alarm levels of each sensor. Note that reading ALM_STS also resets it to 0x0000.

Table 62. ALM_STS (Page 0, Base Address = 0x0C)

Bits	Description (Default = 0x0000)
[15:12]	Not used
11	Barometer alarm flag (1 = alarm is active)
10	Z-axis magnetometer alarm flag (1 = alarm is active)
9	Y-axis magnetometer alarm flag (1 = alarm is active)
8	X-axis magnetometer alarm flag (1 = alarm is active)
[7:6]	Not used
5	Z-axis accelerometer alarm flag (1 = alarm is active)
4	Y-axis accelerometer alarm flag (1 = alarm is active)
3	X-axis accelerometer alarm flag (1 = alarm is active)
2	Z-axis gyroscope alarm flag (1 = alarm is active)
1	Y-axis gyroscope alarm flag (1 = alarm is active)
0	X-axis gyroscope alarm flag (1 = alarm is active)

FIRMWARE REVISION

The FIRM_REV register (see Table 63) provides the firmware revision for the internal processor. Each nibble represents a digit in this revision code. For example, if FIRM_REV = 0x0102, the firmware revision is 1.02.

Table 63. FIRM_REV (Page 3, Base Address = 0x78)

Bits	Description
[15:12]	Binary, revision, 10's digit
[11:8]	Binary, revision, 1's digit
[7:4]	Binary, revision, tenths digit
[3:0]	Binary, revision, hundredths digit

The FIRM_DM register (see Table 64) contains the month and day of the factory configuration date. FIRM_DM[15:12] and FIRM_DM[11:8] contain digits that represent the month of factory configuration. For example, November is the 11th month in a year and represented by FIRM_DM[15:8] = 0x11. FIRM_DM[7:4] and FIRM_DM[3:0] contain digits that represent the day of factory configuration. For example, the 27th day of the month is represented by FIRM_DM[7:0] = 0x27.

Table 64. FIRM_DM (Page 3, Base Address = 0x7A)

Bits	Description
[15:12]	Binary, month 10's digit, range: 0 to 1
[11:8]	Binary, month 1's digit, range: 0 to 9
[7:4]	Binary, day 10's digit, range: 0 to 3
[3:0]	Binary, day 1's digit, range: 0 to 9

The FIRM_Y register (see Table 65) contains the year of the factory configuration date. For example, the year of 2013 is represented by FIRM_Y = 0x2013.

Table 65. FIRM_Y (Page 3, Base Address = 0x7C)

Bits	Description
[15:12]	Binary, year 1000's digit, range: 0 to 9
[11:8]	Binary, year 100's digit, range: 0 to 9
[7:4]	Binary, year 10's digit, range: 0 to 9
[3:0]	Binary, year 1's digit, range: 0 to 9

PRODUCT IDENTIFICATION

The PROD_ID register (see Table 66) contains the binary equivalent of the part number (16,480 = 0x4060), and the SERIAL_NUM register (see Table 67) contains a lot specific serial number.

Table 66. PROD_ID (Page 0, Base Address = 0x7E)

Bits	Description (Default = 0x4060)
[15:0]	Product identification = 0x4060

Table 67. SERIAL_NUM (Page 4, Base Address = 0x20)

Bits	Description
[15:0]	Lot specific serial number

DIGITAL SIGNAL PROCESSING GYROSCOPES/ACCELEROMETERS

Figure 20 provides a block diagram for all of the components and settings that influence the frequency response for the accelerometers and gyroscopes. The sample rate for each accelerometer and gyroscope is 9.84 kHz. Each sensor has its own averaging/decimation filter stage, which reduces the update rate to 2.46 kSPS. When using the external clock option (FNCTIO_CTRL[7:4], see Table 150), the input clock drives a 4-sample burst at a sample rate of 9.84 kSPS, which feeds into the 4× averaging/decimation filter. This results in a data rate that is equal to the input clock frequency. Note that the sensitivity to coning and sculling depends on the sample rate. At 2.46 kHz, the sensitivity is very low, but can become influential at lower sample rates. For best performance when using an external clock, use the maximum input frequency of 2.4 kHz.

AVERAGING/DECIMATION FILTER

The DEC_RATE register (see Table 68) provides user control for the final filter stage (see Figure 20), which averages and decimates the accelerometers, gyroscopes, delta angle, and delta velocity data. Note that the orientation outputs do not go through an averaging stage, prior to decimation. The output sample rate is equal to $2460 / (\text{DEC_RATE} + 1)$. When using the external clock option (FNCTIO_CTRL[7:4], see Table 150), replace the 2460 number in this relationship, with the input clock frequency. For example, turn to Page 3 (DIN = 0x8003), and set DEC_RATE = 0x18 (DIN = 0x8C18, then DIN = 0x8D00) to reduce the output sample rate to 98.4 SPS ($2460 \div 25$).

Table 68. DEC_RATE (Page 3, Base Address = 0x0C)

Bits	Description (Default = 0x0000)
[15:11]	Don't care
[10:0]	Decimation rate, binary format, maximum = 2047 See Figure 20 for impact on sample rate

MAGNETOMETER/BAROMETER

When using the internal sampling clock, the magnetometer output registers (x_MAGN_OUT) update at a rate of 102.5 SPS and the barometer output registers (BAROM_XXX) update at a rate of 51.25 SPS. When using the external clock, the magnetometers update at a rate of 1/24th of the input clock frequency and the barometers update at a rate that is 1/48th of the input clock frequency.

The update rates for the magnetometer and barometers do not change with the DEC_RATE register settings. SYS_E_FLAG[9:8] (see Table 60) offer new data indicator bits that indicate fresh, unread data is in the x_MAGN_OUT and the BAROM_XXX registers. The SEQ_CNT register provides a counter function to help determine when there is new data in the magnetometer and barometer registers.

When SEQ_CNT = 0x0001, there is new data in the magnetometer and barometer output registers. The SEQ_CNT register can be useful during initialization to help synchronize read loops for new data in both magnetometer and barometer outputs. When beginning a continuous read loop, read SEQ_CNT, then subtract this value from the maximum value shown (range) in Table 69 to calculate the number of internal sample cycles until both magnetometer and barometer data is new.

Table 69. SEQ_CNT (Page 0, Base Address = 0x06)

Bits	Description
[15:11]	Don't care
[6:0]	Binary counter: range = 1 to $48 / (\text{DEC_RATE} + 1)$

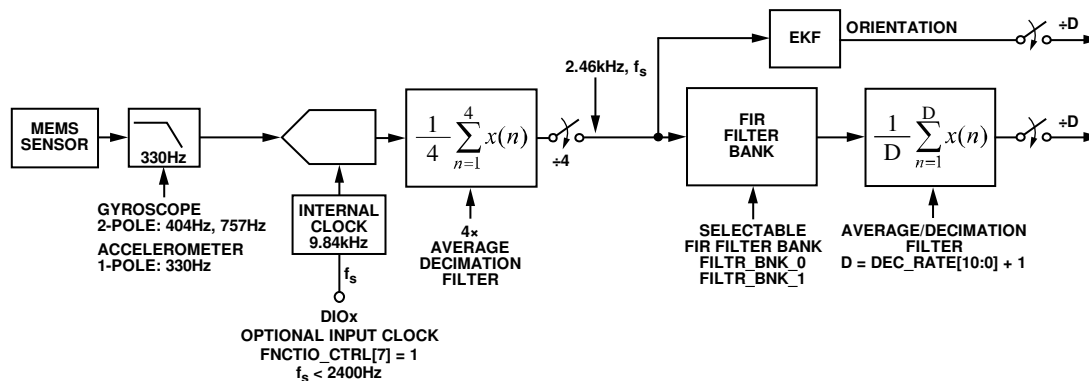

NOTES

1. WHEN FNCTIO_CTRL[7] = 1, EACH CLOCK PULSE ON THE DESIGNATED DIOx LINE (FNCTIO_CTRL[5:4]) STARTS A 4-SAMPLE BURST, AT A SAMPLE RATE OF 9.84kHz. THESE FOUR SAMPLES FEED INTO THE 4x AVERAGE/DECIMATION FILTER, WHICH PRODUCES A DATA RATE THAT IS EQUAL TO THE INPUT CLOCK FREQUENCY.

10278-020

Figure 20. Sampling and Frequency Response Signal Flow

FIR FILTER BANKS

The ADIS16480 provides four configurable, 120-tap FIR filter banks. Each coefficient is 16 bits wide and occupies its own register location with each page. When designing a FIR filter for these banks, use a sample rate of 2.46 kHz and scale the coefficients so that their sum equals 32,768. For filter designs that have less than 120 taps, load the coefficients into the lower portion of the filter and start with Coefficient 1. Make sure that all unused taps are equal to zero, so that they do not add phase delay to the response. The FILTR_BNK_x registers provide three bits per sensor, which configure the filter bank (A, B, C, D) and turn filtering on and off. For example, turn to Page 3 (DIN = 0x8003), then write 0x002F to FILTR_BNK_0 (DIN = 0x962F, DIN = 0x9700) to set the x-axis gyroscope to use the FIR filter in Bank D, to set the y-axis gyroscope to use the FIR filter in Bank B, and to enable these FIR filters in both x- and y-axis gyroscopes. Note that the filter settings update after writing to the upper byte; therefore, always configure the lower byte first. In cases that require configuration to only the lower byte of either FILTR_BNK_0 or FILTR_BNK_1, complete the process by writing 0x00 to the upper byte.

Table 70. FILTR_BNK_0 (Page 3, Base Address = 0x16)

Bits	Description (Default = 0x0000)
15	Don't care
14	Y-axis accelerometer filter enable (1 = enabled)
[13:12]	Y-axis accelerometer filter bank selection: 00 = Bank A, 01 = Bank B, 10 = Bank C, 11 = Bank D
11	X-axis accelerometer filter enable (1 = enabled)
[10:9]	X-axis accelerometer filter bank selection: 00 = Bank A, 01 = Bank B, 10 = Bank C, 11 = Bank D
8	Z-axis gyroscope filter enable (1 = enabled)
[7:6]	Z-axis gyroscope filter bank selection: 00 = Bank A, 01 = Bank B, 10 = Bank C, 11 = Bank D
5	Y-axis gyroscope filter enable (1 = enabled)
[4:3]	Y-axis gyroscope filter bank selection: 00 = Bank A, 01 = Bank B, 10 = Bank C, 11 = Bank D
2	X-axis gyroscope filter enable (1 = enabled)
[1:0]	X-axis gyroscope filter bank selection: 00 = Bank A, 01 = Bank B, 10 = Bank C, 11 = Bank D

Table 71. FILTR_BNK_1 (Page 3, Base Address = 0x18)

Bits	Description (Default = 0x0000)
[15:12]	Don't care
11	Z-axis magnetometer filter enable (1 = enabled)
[10:9]	Z-axis magnetometer filter bank selection: 00 = Bank A, 01 = Bank B, 10 = Bank C, 11 = Bank D
8	Y-axis magnetometer filter enable (1 = enabled)
[7:6]	Y-axis magnetometer filter bank selection: 00 = Bank A, 01 = Bank B, 10 = Bank C, 11 = Bank D
5	X-axis magnetometer filter enable (1 = enabled)
[4:3]	X-axis magnetometer filter bank selection: 00 = Bank A, 01 = Bank B, 10 = Bank C, 11 = Bank D
2	Z-axis accelerometer filter enable (1 = enabled)
[1:0]	Z-axis accelerometer filter bank selection: 00 = Bank A, 01 = Bank B, 10 = Bank C, 11 = Bank D

Filter Memory Organization

Each filter bank uses two pages of the user register structure. See Table 72, Table 73, Table 74, and Table 75 for the register addresses in each filter bank.

Table 72. Filter Bank A Memory Map, FIR_COEF_Axxx

Page	PAGE_ID	Address	Register
5	0x05	0x00	PAGE_ID
5	0x05	0x02 to 0x07	Not used
5	0x05	0x08	FIR_COEF_A000
5	0x05	0x0A	FIR_COEF_A001
5	0x05	0x0C to 0x7C	FIR_COEF_A002 to FIR_COEF_A058
5	0x05	0x7E	FIR_COEF_A059
6	0x06	0x00	PAGE_ID
6	0x06	0x02 to 0x07	Not used
6	0x06	0x08	FIR_COEF_A060
6	0x06	0x0A	FIR_COEF_A061
6	0x06	0x0C to 0x7C	FIR_COEF_A062 to FIR_COEF_A118
6	0x06	0x7E	FIR_COEF_D119

Table 73. Filter Bank B Memory Map, FIR_COEF_Bxxx

Page	PAGE_ID	Address	Register
7	0x07	0x00	PAGE_ID
7	0x07	0x02 to 0x07	Not used
7	0x07	0x08	FIR_COEF_B000
7	0x07	0x0A	FIR_COEF_B001
7	0x07	0x0C to 0x7C	FIR_COEF_B002 to FIR_COEF_B058
7	0x07	0x7E	FIR_COEF_B059
8	0x08	0x00	PAGE_ID
8	0x08	0x02 to 0x07	Not used
8	0x08	0x08	FIR_COEF_B060
8	0x08	0x0A	FIR_COEF_B061
8	0x08	0x0C to 0x7C	FIR_COEF_B062 to FIR_COEF_B118
8	0x08	0x7E	FIR_COEF_B119

Table 74. Filter Bank C Memory Map, FIR_COEF_Cxxx

Page	PAGE_ID	Address	Register
9	0x09	0x00	PAGE_ID
9	0x09	0x02 to 0x07	Not used
9	0x09	0x08	FIR_COEF_C000
9	0x09	0x0A	FIR_COEF_C001
9	0x09	0x0C to 0x7C	FIR_COEF_C002 to FIR_COEF_C058
9	0x09	0x7E	FIR_COEF_C059
10	0x0A	0x00	PAGE_ID
10	0x0A	0x02 to 0x07	Not used
10	0x0A	0x08	FIR_COEF_C060
10	0x0A	0x0A	FIR_COEF_C061
10	0x0A	0x0C to 0x7C	FIR_COEF_C062 to FIR_COEF_C118
10	0x0A	0x7E	FIR_COEF_C119

Table 75. Filter Bank D Memory Map, FIR_COEF_Dxxx

Page	PAGE_ID	Address	Register
11	0x0B	0x00	PAGE_ID
11	0x0B	0x02 to 0x07	Not used
11	0x0B	0x08	FIR_COEF_D000
11	0x0B	0x0A	FIR_COEF_D001
11	0x0B	0x0C to 0x7C	FIR_COEF_D002 to FIR_COEF_D058
11	0x0B	0x7E	FIR_COEF_D059
12	0x0C	0x00	PAGE_ID
12	0x0C	0x02 to 0x07	Not used
12	0x0C	0x08	FIR_COEF_D060
12	0x0C	0x0A	FIR_COEF_D061
12	0x0C	0x0C to 0x7C	FIR_COEF_D062 to FIR_COEF_D118
12	0x0C	0x7E	FIR_COEF_D119

Default Filter Performance

The FIR filter banks have factory programmed filter designs. They are all low-pass filters that have unity dc gain. Table 76 provides a summary of each filter design, and Figure 21 shows the frequency response characteristics. The phase delay is equal to 1/2 of the total number of taps.

Table 76. FIR Filter Descriptions, Default Configuration

FIR Filter Bank	Taps	-3 dB Frequency (Hz)
A	120	310
B	120	55
C	32	275
D	32	63

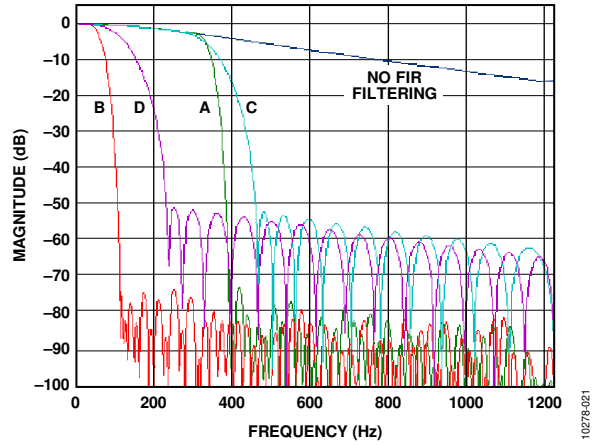

Figure 21. FIR Filter Frequency Response Curves

EXTENDED KALMAN FILTER ALGORITHM

The extended Kalman filter (EKF) continuously estimates the state vector, which includes the four elements in a quaternion orientation array and the bias levels for all three gyroscopes. Figure 22 illustrates the iterative process used in the EKF, which uses angular rate measurements (gyroscopes) to predict orientation updates and then makes corrections using accelerometer and magnetometer measurements. In addition to continuous state estimation, the EKF also estimates the error covariance terms. Using the covariance terms, current orientation, and gyroscope sensor measurements, the algorithm computes a Kalman gain that provides a weighting value for each sensor contribution to the state vector. The ADIS16480 has factory settings for the covariance terms but provides access to them in the form of user-configuration registers, for fine tuning, based on application-specific conditions/requirements.

COVARIANCE TERMS

Table 77 through Table 80 provides register information for the gyroscope noise/RRW process covariance (Q) terms. Table 81 through Table 84 provides register information for the accelerometer/magnetometer measurement covariance (R) terms. These covariance terms use the IEEE 32-bit floating-point format. Each term has two registers, one for the upper word and one for the lower word.

Table 77. QCVR_NOIS_UPR (Page 3, Base Address = 0x62)

Bits	Description (Default = 0x3727)
[15:0]	Gyroscope noise covariance term, upper word

Table 78. QCVR_NOIS_LWR (Page 3, Base Address = 0x60)

Bits	Description (Default = 0xC5AC)
[15:0]	Gyroscope noise covariance term, lower word

Table 79. QCVR_RRW_UPR (Page 3, Base Address = 0x66)

Bits	Description (Default = 0x2E5B)
[15:0]	Gyroscope rate random walk (RRW) covariance term, upper word

Table 80. QCVR_RRW_LWR (Page 3, Base Address = 0x64)

Bits	Description (Default = 0xE6FF)
[15:0]	Gyroscope rate random walk (RRW) covariance term, lower word

Table 81. RCVR_ACC_UPR (Page 3, Base Address = 0x6E)

Bits	Description (Default = 0x3189)
[15:0]	Accelerometer measurement variance term, upper word

Table 82. RCVR_ACC_LWR (Page 3, Base Address = 0x6C)

Bits	Description (Default = 0x705F)
[15:0]	Accelerometer measurement variance term, lower word

Table 83. RCVR_MAG_UPR (Page 3, Base Address = 0x72)

Bits	Description (Default = 0x32AB)
[15:0]	Magnetometer measurement variance term, upper word

Table 84. RCVR_MAG_LWR (Page 3, Base Address = 0x70)

Bits	Description (Default = 0xCC77)
[15:0]	Magnetometer measurement variance term, lower word

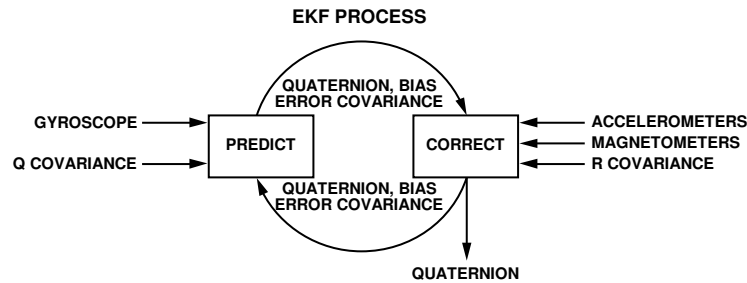

Figure 22. EKF Process

10278-002

REFERENCE FRAME

During the power-on initialization and reset recovery operations, the ADIS16480 sets the accelerometer and magnetometer references for use in the orientation computation. During this process, the gravity vector becomes the accelerometer reference and the magnetometer reference computation includes the following steps: measure horizontal and vertical components of the magnetic field and align the horizontal component to magnetic north. This also measures the inclination, which removes this requirement from an external system. The resulting reference frame is a local ENU inertial frame formed by the y-axis pointing at magnetic north, the z-axis pointing up, and the x-axis completing the right-hand frame by pointing east.

REFERENCE TRANSFORMATION MATRIX

The reference transformation matrix, R_{ij} , provides a user-programmable alignment function for orientation alignment to a local navigation frame. Another common name for this function in navigation system literature is the coordinate transformation matrix.

$$R_{ij} = \begin{bmatrix} R_{11} & R_{12} & R_{13} \\ R_{21} & R_{22} & R_{23} \\ R_{31} & R_{32} & R_{33} \end{bmatrix}$$

When this matrix is equal to an identity matrix (factory default), the local navigation frame matches true level, with respect to gravity, and magnetic north. The tare command automatically calculates and loads the matrix values that establish the current ADIS16480 orientation as the reference orientation. When the ADIS16480 is in the desired reference orientation, initiate the tare command by setting GLOB_CMD[8] = 1 (DIN = 0x8003, then DIN = 0x8301, see Table 147).

Each element in this matrix is associated with a register that provides read and write access. See Table 85 through Table 93, for these registers. Use these registers to define the local navigation frame, based on system generated requirements. Each element is the cross product of the unit vectors that describe the axes of the two frames, which are equal to the cosines of the angles between the axes. Units of rotation vary by ± 1 . When writing to these registers, write to R33 last because a write to the upper byte of this register causes all nine registers to update inside of the ADIS16480.

Table 85. REFMTX_R11 (Page 2, Base Address = 0x62)

Bits	Description (Default = 0x7FFF)
15	Sign bit
[14:0]	Magnitude, binary, 1 LSB = 1/2 ¹⁵

Table 86. REFMTX_R12 (Page 2, Base Address = 0x64)

Bits	Description (Default = 0x0000)
15	Sign bit
[14:0]	Magnitude, binary, 1 LSB = 1/2 ¹⁵

Table 87. REFMTX_R13 (Page 2, Base Address = 0x66)

Bits	Description (Default = 0x0000)
15	Sign bit
[14:0]	Magnitude, binary, 1 LSB = 1/2 ¹⁵

Table 88. REFMTX_R21 (Page 2, Base Address = 0x68)

Bits	Description (Default = 0x0000)
15	Sign bit
[14:0]	Magnitude, binary, 1 LSB = 1/2 ¹⁵

Table 89. REFMTX_R22 (Page 2, Base Address = 0x6A)

Bits	Description (Default = 0x7FFF)
15	Sign bit
[14:0]	Magnitude, binary, 1 LSB = 1/2 ¹⁵

Table 90. REFMTX_R23 (Page 2, Base Address = 0x6C)

Bits	Description (Default = 0x0000)
15	Sign bit
[14:0]	Magnitude, binary, 1 LSB = 1/2 ¹⁵

Table 91. REFMTX_R31 (Page 2, Base Address = 0x6E)

Bits	Description (Default = 0x0000)
15	Sign bit
[14:0]	Magnitude, binary, 1 LSB = 1/2 ¹⁵

Table 92. REFMTX_R32 (Page 2, Base Address = 0x70)

Bits	Description (Default = 0x0000)
15	Sign bit
[14:0]	Magnitude, binary, 1 LSB = 1/2 ¹⁵

Table 93. REFMTX_R33 (Page 2, Base Address = 0x72)

Bits	Description (Default = 0x7FFF)
15	Sign bit
[14:0]	Magnitude, binary, 1 LSB = 1/2 ¹⁵

DECLINATION

The DECLN_ANGL register provides a user-programmable input that can shift the reference frame from magnetic north to geodetic north (or any arbitrary azimuth heading).

Table 94. DECLN_ANGL (Page 3, Base Address = 0x54)

Bits	Description (Default = 0x0000)
[15:0]	Declination angle, twos complement Scale factor = $\pi/2^{15}$ radians/LSB

ADAPTIVE OPERATION

The EKF_CNFG register, in Table 95, offers a number of control bits for customizing EKF operation.

Table 95. EKF_CNFG (Page 3, Base Address = 0x50)

Bits	Description (Default = 0x0200)
[15:13]	Not used
12	Automatic reset recovery from divergence 1 = enable, 0 = disable
[11:10]	Not used
9	Fade enable 1 = enable, 0 = disable
8	Adaptive EKF enable 1 = enable, 0 = disable
[7:5]	Not used
4	Orientation format control 1 = rotation matrix, 0 = quaternion and Euler
3	Body frame/local navigation frame selection 1 = body frame, 0 = local navigation frame
2	Not for external use, always set to 0
1	Magnetometer disable 1 = enable, 0 = disable
0	Gravity removal (from accelerometers) 1 = enable, 0 = disable

Adaptive EKF Enable Bit

EKF_CNFG[8] (see Table 95) provides an on/off control bit for the adaptive part of the EKF function. The adaptive part of the EKF computes the measurement covariance terms (R), which enables real-time adjustments for vibration and magnetic field disturbances. See Table 81 through Table 84 for read access to the measurement covariance terms.

Automatic EKF Divergence Reset Control Bit

The EKF algorithm monitors the normalized innovation squared parameter to detect divergence. The normalized innovation is the innovation (predicted measurements minus actual measurements) divided by the statistically computed expected error, which is based on the error covariance and the measurement covariance. The normalized innovation is used to detect EKF divergence and report it in the SYS_E_FLAG[13] bit (see Table 60), and to trigger an automatic EKF reset when EKF_CFG[12] = 1. The automatic reset process works best when the divergence comes from short-term, transient inertial conditions. Use this function only when predeployment validation testing can confirm that it performs well through all application conditions. If there is any sign of instability, keep this function off (EKF_CFG[12] = 0), monitor SYS_E_FLAG[13] to test for divergence in the EKF, and, after detecting divergence, use the manual EKF reset function in GLOB_CMD[15] (see Table 147) or the full software reset in GLB_CMD[7] to initiate a reset in the EKF. Note that this recovery process requires zero inertial motion and a magnetic environment free of interference to optimize postrecovery accuracy.

Gyroscope Fade Control Bit

EKF_CNFG[9] (see Table 95) provides an on/off control bit for the gyroscope fade function, which is an internal adjustment of the gyroscope process covariance terms. This reduces the impact of gyroscope scale errors during transient events, where the gyroscope rates are quickly changing. The fade function effectively reduces the weighting of the gyroscope measurements, with respect to the accelerometers and magnetometers, during these transient events. The adjustment terminates when the rates return to zero.

Body Frame/Local Navigation Frame Bit

EKF_CNFG[3] (see Table 95) provides a bit for selecting between the body frame and local navigation frame. When using the local navigation frame, the body sensor measurements are translated into the local navigation frame before being loaded into the output registers. Absent any external acceleration, the accelerometer outputs remain unchanged as the ADIS16480 is rotated when in this mode. Set EKF_CNFG[3] = 1 (DIN = 0x8003, DIN = 0xD008, DIN = 0xD102) to establish the body frame as the reference frame and to preserve the fade enable setting.

Orientation Format Control Bit

EKF_CNFG[4] (see Table 95) provides a selection bit for angle data format. Set EKF_CNFG[4] = 1 (DIN = 0x8003, DIN = 0xD010, DIN = 0xD102) to use the rotation matrix format and to preserve the fade enable setting.

Magnetometer Disable Control Bit

EKF_CNFG[1] (see Table 95) provides an on/off control bit for the magnetometer disable function, which disables the magnetometer influence over angle calculations in the EKF.

Gravity Removal Control Bit

EKF_CNFG[0] (see Table 95) provides an on/off control bit for the gravity removal function, which removes the gravity component from the accelerometer outputs. This function applies only when using the local navigation frame mode.

Linear Acceleration/Magnetic Disturbance Detection

The ADIS16480 checks the magnitudes of the accelerometers and magnetometers and compares their values against those of the corresponding reference vectors. If the difference exceeds the percentage programmed in the disturbance thresholds, the algorithm automatically ignores the affected sensor group for the duration of the external disturbance.

Table 96. ACC_DISTB_THR (Page 3, Base Address = 0x56)

Bits	Description (Default = 0x0020)
[15:8]	Not used
[7:0]	Threshold, binary, scale factor = 0.39%/LSB (50%/128)

Table 97. MAG_DISTB_THR (Page 3, Base Address = 0x58)

Bits	Description (Default = 0x0030)
[15:8]	Not used
[7:0]	Threshold, binary, scale factor = 0.39%/LSB (50%/128)

CALIBRATION

The ADIS16480 factory calibration produces correction formulas for the gyroscopes, accelerometers, magnetometers, and barometers, and then programs them into the flash memory. In addition, there are a series of user configurable calibration registers, for in-system tuning.

GYROSCOPES

The use calibration for the gyroscopes includes registers for adjusting bias and sensitivity, as shown in Figure 23.

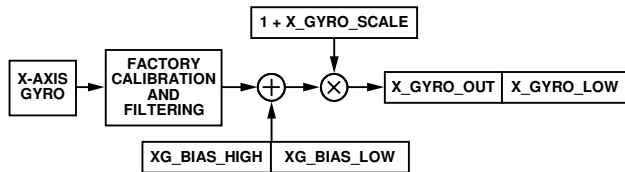

Figure 23. User Calibration Signal Path, Gyroscopes

Manual Bias Correction

The xG_BIAS_HIGH registers (see Table 98, Table 99, and Table 100) and xG_BIAS_LOW registers (see Table 101, Table 102, and Table 103) provide a bias adjustment function for the output of each gyroscope sensor.

Table 98. XG_BIAS_HIGH (Page 2, Base Address = 0x12)

Bits	Description (Default = 0x0000)
[15:0]	X-axis gyroscope offset correction, upper word twos complement, 0°/sec = 0x0000, 1 LSB = 0.02°/sec

Table 99. YG_BIAS_HIGH (Page 2, Base Address = 0x16)

Bits	Description (Default = 0x0000)
[15:0]	Y-axis gyroscope offset correction, upper word; twos complement, 0°/sec = 0x0000, 1 LSB = 0.02°/sec

Table 100. ZG_BIAS_HIGH (Page 2, Base Address = 0x1A)

Bits	Description (Default = 0x0000)
[15:0]	Z-axis gyroscope offset correction, upper word; twos complement, 0°/sec = 0x0000, 1 LSB = 0.02°/sec

Table 101. XG_BIAS_LOW (Page 2, Base Address = 0x10)

Bits	Description (Default = 0x0000)
[15:0]	X-axis gyroscope offset correction, lower word; twos complement, 0°/sec = 0x0000, 1 LSB = 0.02°/sec ÷ 2 ¹⁶ = ~0.000000305°/sec

Table 102. YG_BIAS_LOW (Page 2, Base Address = 0x14)

Bits	Description (Default = 0x0000)
[15:0]	Y-axis gyroscope offset correction, lower word; twos complement, 0°/sec = 0x0000, 1 LSB = 0.02°/sec ÷ 2 ¹⁶ = ~0.000000305°/sec

Table 103. ZG_BIAS_LOW (Page 2, Base Address = 0x18)

Bits	Description (Default = 0x0000)
[15:0]	Z-axis gyroscope offset correction, lower word twos complement, 0°/sec = 0x0000, 1 LSB = 0.02°/sec ÷ 2 ¹⁶ = ~0.000000305°/sec

Manual Sensitivity Correction

The x_GYRO_SCALE registers enable sensitivity adjustment (see Table 104, Table 105, and Table 106).

Table 104. X_GYRO_SCALE (Page 2, Base Address = 0x04)

Bits	Description (Default = 0x0000)
[15:0]	X-axis gyroscope scale correction; twos complement, 0x0000 = unity gain, 1 LSB = 1 ÷ 2 ¹⁵ = ~0.003052%

Table 105. Y_GYRO_SCALE (Page 2, Base Address = 0x06)

Bits	Description (Default = 0x0000)
[15:0]	Y-axis gyroscope scale correction; twos complement, 0x0000 = unity gain, 1 LSB = 1 ÷ 2 ¹⁵ = ~0.003052%

Table 106. Z_GYRO_SCALE (Page 2, Base Address = 0x08)

Bits	Description (Default = 0x0000)
[15:0]	Z-axis gyroscope scale correction; twos complement, 0x0000 = unity gain, 1 LSB = 1 ÷ 2 ¹⁵ = ~0.003052%

Linear Acceleration on Effect on Gyroscope Bias

MEMS gyroscopes typically have a bias response to linear acceleration that is normal to their axis of rotation. The ADIS16480 offers an optional compensation function for this effect. The factory default setting for Register 0x00C0 enables this function. To turn it off, turn to Page 3 (DIN = 0x8003) and set CONFIG[7] = 0 (DIN = 0x8A40, DIN = 0x8B00). Note that this also keeps the point of percussion alignment function enabled.

Table 107. CONFIG (Page 3, Base Address = 0x0A)

Bits	Description (Default = 0x00C0)
[15:8]	Not used
7	Linear-g compensation for gyroscopes (1 = enabled)
6	Point of percussion alignment (1 = enabled)
[5:2]	Not used
1	Real-time clock, daylight savings time (1: enabled, 0: disabled)
0	Real-time clock control (1: relative/elapsed timer mode, 0: calendar mode)

ACCELEROMETERS

The user calibration for the accelerometers includes registers for adjusting bias and sensitivity, as shown in Figure 24.

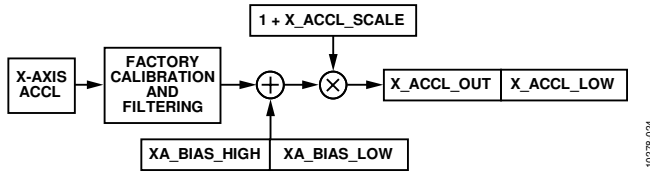

Figure 24. User Calibration Signal Path, Accelerometers

Manual Bias Correction

The xA_BIAS_HIGH registers (see Table 108, Table 109, and Table 110) and xA_BIAS_LOW registers (see Table 111, Table 112, and Table 113) provide a bias adjustment function for the output of each accelerometer sensor. The xA_BIAS_HIGH registers use the same format as x_ACCL_OUT registers. The xA_BIAS_LOW registers use the same format as x_ACCL_LOW registers.

Table 108. XA_BIAS_HIGH (Page 2, Base Address = 0x1E)

Bits	Description (Default = 0x0000)
[15:0]	X-axis accelerometer offset correction, high word, Twos complement, 0 g = 0x0000, 1 LSB = 0.8 mg

Table 109. YA_BIAS_HIGH (Page 2, Base Address = 0x22)

Bits	Description (Default = 0x0000)
[15:0]	Y-axis accelerometer offset correction, high word, Twos complement, 0 g = 0x0000, 1 LSB = 0.8 mg

Table 110. ZA_BIAS_HIGH (Page 2, Base Address = 0x26)

Bits	Description (Default = 0x0000)
[15:0]	Z-axis accelerometer offset correction, high word, Twos complement, 0 g = 0x0000, 1 LSB = 0.8 mg

Table 111. XA_BIAS_LOW (Page 2, Base Address = 0x1C)

Bits	Description (Default = 0x0000)
[15:0]	X-axis accelerometer offset correction, low word, Twos complement, 0 g = 0x0000, 1 LSB = 0.8 mg ÷ 2 ¹⁶ = ~0.0000122 mg

Table 112. YA_BIAS_LOW (Page 2, Base Address = 0x20)

Bits	Description (Default = 0x0000)
[15:0]	Y-axis accelerometer offset correction, low word, Twos complement, 0 g = 0x0000, 1 LSB = 0.8 mg ÷ 2 ¹⁶ = ~0.0000122 mg

Table 113. ZA_BIAS_LOW (Page 2, Base Address = 0x24)

Bits	Description (Default = 0x0000)
[15:0]	Z-axis accelerometer offset correction, low word; Twos complement, 0 g = 0x0000, 1 LSB = 0.8 mg ÷ 2 ¹⁶ = ~0.0000122 mg

Manual Sensitivity Correction

The x_ACCL_SCALE registers enable sensitivity adjustment (see Table 114, Table 115, and Table 116).

Table 114. X_ACCL_SCALE (Page 2, Base Address = 0x0A)

Bits	Description (Default = 0x0000)
[15:0]	X-axis accelerometer scale correction, Twos complement, 0x0000 = unity gain, 1 LSB = 1 ÷ 2 ¹⁵ = ~0.003052%

Table 115. Y_ACCL_SCALE (Page 2, Base Address = 0x0C)

Bits	Description (Default = 0x0000)
[15:0]	Y-axis accelerometer scale correction, Twos complement, 0x0000 = unity gain, 1 LSB = 1 ÷ 2 ¹⁵ = ~0.003052%

Table 116. Z_ACCL_SCALE (Page 2, Base Address = 0x0E)

Bits	Description (Default = 0x0000)
[15:0]	Z-axis accelerometer scale correction, Twos complement, 0x0000 = unity gain, 1 LSB = 1 ÷ 2 ¹⁵ = ~0.003052%

MAGNETOMETERS

The user calibration registers enable both hard iron and soft iron correction, as shown in the following relationship:

$$\begin{bmatrix} M_{XC} \\ M_{YC} \\ M_{ZC} \end{bmatrix} = \begin{bmatrix} 1 + S_{11} & S_{12} & S_{13} \\ S_{21} & 1 + S_{22} & S_{23} \\ S_{31} & S_{32} & 1 + S_{33} \end{bmatrix} \times \begin{bmatrix} M_X \\ M_Y \\ M_Z \end{bmatrix} + \begin{bmatrix} H_X \\ H_Y \\ H_Z \end{bmatrix}$$

The M_X, M_Y, and M_Z variables represent the magnetometer data, prior to application of the user correction formula. The M_{XC}, M_{YC}, and M_{ZC} represent the magnetometer data, after the application of the user correction formula.

Hard Iron Correction

Table 117, Table 118, and Table 119 describe the register format for the hard iron correction factors: H_x, H_y, and H_z. These registers use a twos complement format. Table 120 provides some numerical examples for converting the digital codes for these registers into their decimal equivalents.

Table 117. HARD_IRON_X (Page 2, Base Address = 0x28)

Bits	Description (Default = 0x0000)
[15:0]	X-axis magnetometer hard iron correction factor, H _x Twos complement, ±3.2767 gauss range, 0.1 mgauss/LSB, 0 gauss = 0x0000 (see Table 120)

Table 118. HARD_IRON_Y (Page 2, Base Address = 0x2A)

Bits	Description (Default = 0x0000)
[15:0]	Y-axis magnetometer hard iron correction factor, H _y Twos complement, ±3.2767 gauss range, 0.1 mgauss/LSB, 0 gauss = 0x0000 (see Table 120)

Table 119. HARD_IRON_Z (Page 2, Base Address = 0x2C)

Bits	Description (Default = 0x0000)
[15:0]	Z-axis magnetometer hard iron correction factor, H _z Twos complement, ±3.2767 gauss range, 0.1 mgauss/LSB, 0 gauss = 0x0000 (see Table 120)

Table 120. HARD_IRON_x Data Format Examples

Magnetic Field	Decimal	Hex	Binary
+3.2767 gauss	+32,767	0x7FFF	0111 1111 1111 1111
+0.2 mgauss	+2	0x0002	0000 0000 0000 0010
+0.1 mgauss	+1	0x0001	0000 0000 0000 0001
0 gauss	0	0x0000	0000 0000 0000 0000
-0.1 mgauss	-1	0xFFFF	1111 1111 1111 1111
-0.2 mgauss	-2	0xFFFE	1111 1111 1111 1110
-3.2768 gauss	-32,768	0x8000	1000 0000 0000 0000

Soft Iron Correction Matrix

The soft iron correction matrix contains correction factors for both sensitivity (S₁₁, S₂₂, S₃₃) and alignment (S₁₂, S₁₃, S₂₁, S₂₃, S₃₁, S₃₂). The registers that represent each soft iron correction factor are in Table 121 (S₁₁), Table 122 (S₁₂), Table 123 (S₁₃), Table 124 (S₂₁), Table 125 (S₂₂), Table 126 (S₂₃), Table 127 (S₃₁), Table 128 (S₃₂), and Table 129 (S₃₃). Table 130 offers some numerical examples for converting between the digital codes and their effect on the magnetometer output, in terms of percent-change.

Table 121. SOFT_IRON_S11 (Page 2, Base Address = 0x2E)

Bits	Description (Default = 0x0000)
[15:0]	Magnetometer soft iron correction factor, S ₁₁ Twos complement format, see Table 130 for examples

Table 122. SOFT_IRON_S12 (Page 2, Base Address = 0x30)

Bits	Description (Default = 0x0000)
[15:0]	Magnetometer soft iron correction factor, S ₁₂ Twos complement format, see Table 130 for examples

Table 123. SOFT_IRON_S13 (Page 2, Base Address = 0x32)

Bits	Description (Default = 0x0000)
[15:0]	Magnetometer soft iron correction factor, S ₁₃ Twos complement format, see Table 130 for examples

Table 124. SOFT_IRON_S21 (Page 2, Base Address = 0x34)

Bits	Description (Default = 0x0000)
[15:0]	Magnetometer soft iron correction factor, S ₂₁ Twos complement format, see Table 130 for examples

Table 125. SOFT_IRON_S22 (Page 2, Base Address = 0x36)

Bits	Description (Default = 0x0000)
[15:0]	Magnetometer soft iron correction factor, S ₂₂ Twos complement format, see Table 130 for examples

Table 126. SOFT_IRON_S23 (Page 2, Base Address = 0x38)

Bits	Description (Default = 0x0000)
[15:0]	Magnetometer soft iron correction factor, S ₂₃ Twos complement format, see Table 130 for examples

Table 127. SOFT_IRON_S31 (Page 2, Base Address = 0x3A)

Bits	Description (Default = 0x0000)
[15:0]	Magnetometer soft iron correction factor, S ₃₁ Twos complement format, see Table 130 for examples

Table 128. SOFT_IRON_S32 (Page 2, Base Address = 0x3C)

Bits	Description (Default = 0x0000)
[15:0]	Magnetometer soft iron correction factor, S ₃₂ Twos complement format, see Table 130 for examples

Table 129. SOFT_IRON_S33 (Page 2, Base Address = 0x3E)

Bits	Description (Default = 0x0000)
[15:0]	Magnetometer soft iron correction factor, S ₃₃ Twos complement format, see Table 130 for examples

Table 130. Soft Iron Correction, Numerical Examples

Delta (%)	Decimal	Hex	Binary
+100 - 1/2 ¹⁶	+32,767	0x7FFF	0111 1111 1111 1111
+200/2 ¹⁵	+2	0x0002	0000 0000 0000 0010
+100/2 ¹⁵	+1	0x0001	0000 0000 0000 0001
0	0	0x0000	0000 0000 0000 0000
-100/2 ¹⁵	-1	0xFFFF	1111 1111 1111 1111
-200/2 ¹⁵	-2	0xFFFE	1111 1111 1111 1110
-100	-32,768	0x8000	1000 0000 0000 0000

BAROMETERS

The BR_BIAS_HIGH register (see Table 131) and BR_BIAS_LOW register (Table 132) provide an offset control function and use the same format as the output registers, BAROM_OUT and BAROM_LOW.

Table 131. BR_BIAS_HIGH (Page 2, Base Address = 0x42)

Bits	Description (Default = 0x0000)
[15:0]	Barometric pressure bias correction factor, high word Twos complement, ±1.3 bar measurement range, 0 bar = 0x0000, 1 LSB = 40 μbar

Table 132. BR_BIAS_LOW (Page 2, Base Address = 0x40)

Bits	Description (Default = 0x0000)
[15:0]	Barometric pressure bias correction factor, low word Twos complement, ±1.3 bar measurement range, 0 bar = 0x0000, 1 LSB = $40 \mu\text{bar} \div 2^{16} = \sim 0.00061 \mu\text{bar}$

RESTORING FACTORY CALIBRATION

Turn to Page 3 (DIN = 0x8003) and set GLOB_CMD[6] = 1 (DIN = 0x8240, DIN = 0x8300) to execute the factory calibration restore function. This function resets each user calibration register to zero, resets all sensor data to 0, and automatically updates the flash memory within 72 ms. See Table 147 for more information on GLOB_CMD.

POINT OF PERCUSSION ALIGNMENT

CONFIG[6] offers a point of percussion alignment function that maps the accelerometer sensors to the corner of the package identified in Figure 25. To activate this feature, turn to Page 3 (DIN = 0x8003), then set CONFIG[6] = 1 (DIN = 0x8A40, DIN = 0x8B00). See Table 107 for more information on the CONFIG register.

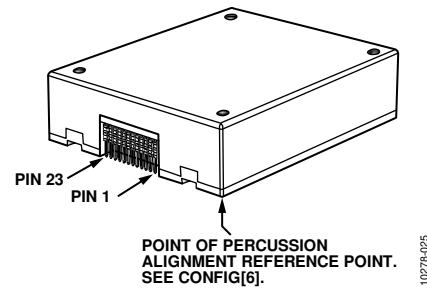

Figure 25. Point of Percussion Reference Point

ALARMS

Each sensor has an independent alarm function that provides controls for alarm magnitude, polarity, and enabling a dynamic rate of change option. The ALM_STS register (see Table 62) contains the alarm output flags and the FNCTIO_CTRL register (see Table 150) provides an option for configuring one of the digital I/O lines as an alarm indicator.

STATIC ALARM USE

The static alarm setting compares each sensor output with the trigger settings in the xx_ALM_MAGN registers (see Table 133 through Table 142) of that sensor. The polarity controls for each alarm are in the ALM_CNFG_x registers (see Table 143, Table 144, Table 145) establish the relationship for the condition that causes the corresponding alarm flag to be active. For example, when ALM_CNFG_0[13] = 1, the alarm flag for the x-axis accelerometer (ALM_STS[3], see Table 62) becomes active (equal to 1) when X_ACCL_OUT is greater than XA_ALM_MAGN.

DYNAMIC ALARM USE

The dynamic alarm setting provides the option to compare the change in each sensor output over a period of 48.7 ms with the xx_ALM_MAGN register of that sensor.

Table 133. XG_ALM_MAGN (Page 3, Base Address = 0x28)

Bits	Description (Default = 0x0000)
[15:0]	X-axis gyroscope alarm threshold settings, Twos complement, 0°/sec = 0x0000, 1 LSB = 0.02°/sec

Table 134. YG_ALM_MAGN (Page 3, Base Address = 0x2A)

Bits	Description (Default = 0x0000)
[15:0]	Y-axis gyroscope alarm threshold settings, Twos complement, 0°/sec = 0x0000, 1 LSB = 0.02°/sec

Table 135. ZG_ALM_MAGN (Page 3, Base Address = 0x2C)

Bits	Description (Default = 0x0000)
[15:0]	Z-axis gyroscope alarm threshold settings, Twos complement, 0°/sec = 0x0000, 1 LSB = 0.02°/sec

Table 136. XA_ALM_MAGN (Page 3, Base Address = 0x2E)

Bits	Description (Default = 0x0000)
[15:0]	X-axis accelerometer alarm threshold settings, Twos complement, 0 g = 0x0000, 1 LSB = 0.8 mg

Table 137. YA_ALM_MAGN (Page 3, Base Address = 0x30)

Bits	Description (Default = 0x0000)
[15:0]	Y-axis accelerometer alarm threshold settings, Twos complement, 0 g = 0x0000, 1 LSB = 0.8 mg

Table 138. ZA_ALM_MAGN (Page 3, Base Address = 0x32)

Bits	Description (Default = 0x0000)
[15:0]	Z-axis accelerometer alarm threshold settings, Twos complement, 0 g = 0x0000, 1 LSB = 0.8 mg

Table 139. XM_ALM_MAGN (Page 3, Base Address = 0x34)

Bits	Description (Default = 0x0000)
[15:0]	X-axis magnetometer alarm threshold settings, Twos complement, 0 gauss = 0x0000, 1 LSB = 0.1 mgauss

Table 140. YM_ALM_MAGN (Page 3, Base Address = 0x36)

Bits	Description (Default = 0x0000)
[15:0]	Y-axis magnetometer alarm threshold settings, Twos complement, 0 gauss = 0x0000, 1 LSB = 0.1 mgauss

Table 141. ZM_ALM_MAGN (Page 3, Base Address = 0x38)

Bits	Description (Default = 0x0000)
[15:0]	Z-axis magnetometer alarm threshold settings, Twos complement, 0 gauss = 0x0000, 1 LSB = 0.1 mgauss

Table 142. BR_ALM_MAGN (Page 3, Base Address = 0x3A)

Bits	Description (Default = 0x0000)
[15:0]	Z-axis barometer alarm threshold settings, Twos complement, 0 bar = 0x0000, 1 LSB = 40 μbar

Table 143. ALM_CNFG_0 (Page 3, Base Address = 0x20)

Bits	Description (Default = 0x0000)
15	X-axis accelerometer alarm (1 = enabled)
14	Not used
13	X-axis accelerometer alarm polarity (1 = greater than)
12	X-axis accelerometer dynamic enable (1 = enabled)
11	Z-axis gyroscope alarm (1 = enabled)
10	Not used
9	Z-axis gyroscope alarm polarity (1 = greater than)
8	Z-axis gyroscope dynamic enable (1 = enabled)
7	Y-axis gyroscope alarm (1 = enabled)
6	Not used
5	Y-axis gyroscope alarm polarity (1 = greater than)
4	Y-axis gyroscope dynamic enable (1 = enabled)
3	X-axis gyroscope alarm (1 = enabled)
2	Not used
1	X-axis gyroscope alarm polarity (1 = greater than)
0	X-axis gyroscope dynamic enable (1 = enabled)

Table 144. ALM_CNFG_1 (Page 3, Base Address = 0x22)

Bits	Description (Default = 0x0000)
15	Y-axis magnetometer alarm (1 = enabled)
14	Not used
13	Y-axis magnetometer alarm polarity (1 = greater than)
12	Y-axis magnetometer dynamic enable (1 = enabled)
11	X-axis magnetometer (1 = enabled)
10	Not used
9	X-axis magnetometer alarm polarity (1 = greater than)
8	X-axis magnetometer dynamic enable (1 = enabled)
7	Z-axis accelerometer alarm (1 = enabled)
6	Not used
5	Z-axis accelerometer alarm polarity (1 = greater than)
4	Z-axis accelerometer dynamic enable (1 = enabled)
3	Y-axis accelerometer alarm (1 = enabled)
2	Not used
1	Y-axis accelerometer alarm polarity (1 = greater than)
0	Y-axis accelerometer dynamic enable (1 = enabled)

Table 145. ALM_CNFG_2 (Page 3, Base Address = 0x24)

Bits	Description (Default = 0x0000)
[15:8]	Not used
7	Barometer alarm (1 = enabled)
6	Not used
5	Barometer alarm polarity (1 = greater than)
4	Barometer dynamic enable (1 = enabled)
3	Z-axis magnetometer alarm (1 = enabled)
2	Not used
1	Z-axis magnetometer alarm polarity (1 = greater than)
0	Z-axis magnetometer dynamic enable (1 = enabled)

Alarm Example

Table 146 offers an alarm configuration example, which sets the z-axis gyroscope alarm to trip when $Z_GYRO_OUT > 131.1^\circ/\text{sec}$ (0x199B).

Table 146. Alarm Configuration Example

DIN	Description
0xAC9B	Set ZG_ALM_MAGN[7:0] = 0x9B
0xAD19	Set ZG_ALM_MAGN[15:8] = 0x19
0xA000	Set ALM_CNFG_0[7:0] = 0x00
0xA10A	Set ALM_CNFG_0[15:8] = 0x0A

SYSTEM CONTROLS

The ADIS16480 provides a number of system level controls for managing its operation, which include reset, self-test, calibration, memory management, and I/O configuration.

GLOBAL COMMANDS

The GLOB_CMD register (see Table 147) provides trigger bits for several operations. Write 1 to the appropriate bit in GLOB_CMD to start a function. After the function completes, the bit restores to 0.

Table 147. GLOB_CMD (Page 3, Base Address = 0x02)

Bits	Description	Execution Time
15	EKF reset	416 ms
[14:10]	Not used	Not applicable
9	Reset the reference rotation matrix	1 sample period
8	Tare command	1 sample period
7	Software reset	1.8 seconds
6	Factory calibration restore	1 sample period
[5:4]	Not used	Not applicable
3	Flash memory update	1100 ms
2	Flash memory test	53 ms
1	Self-test	12 ms
0	Not used	Not applicable

Software Reset

Turn to Page 3 (DIN = 0x8003) and then set GLOB_CMD[7] = 1 (DIN = 0x8280, DIN = 0x8300) to reset the operation, which removes all data, initializes all registers from their flash settings, and starts data collection. This function provides a firmware alternative to the RST pin (see Table 6, Pin 8).

Automatic Self-Test

Turn to Page 3 (DIN = 0x8003) and then set GLOB_CMD[1] = 1 (DIN = 0x8202, then DIN = 0x8300) to run an automatic self-test routine, which executes the following steps:

1. Measure output on each sensor.
2. Activate self-test on each sensor.
3. Measure output on each sensor.
4. Deactivate the self-test on each sensor.
5. Calculate the difference with self-test on and off.
6. Compare the difference with internal pass/fail criteria.
7. Report the pass/fail results for each sensor in DIAG_STS.

After waiting 12 ms for this test to complete, turn to Page 0 (DIN = 0x8000) and read DIAG_STS using DIN = 0x0A00. Note that using an external clock can extend this time. When using an external clock of 100 Hz, this time extends to 35 ms. Note that 100 Hz is too slow for optimal sensor performance.

MEMORY MANAGEMENT

The data retention of the flash memory depends on the temperature and the number of write cycles. Figure 26 characterizes the dependence on temperature, and the FLSHCNT_LOW and FLSHCNT_HIGH registers (see Table 148 and Table 149) provide a running count of flash write cycles. The flash updates every time GLOB_CMD[6] or GLOB_CMD[3] is set to 1.

Table 148. FLSHCNT_LOW (Page 2, Base Address = 0x7C)

Bits	Description
[15:0]	Binary counter; number of flash updates, lower word

Table 149. FLSHCNT_HIGH (Page 2, Base Address = 0x7E)

Bits	Description
[15:0]	Binary counter; number of flash updates, upper word

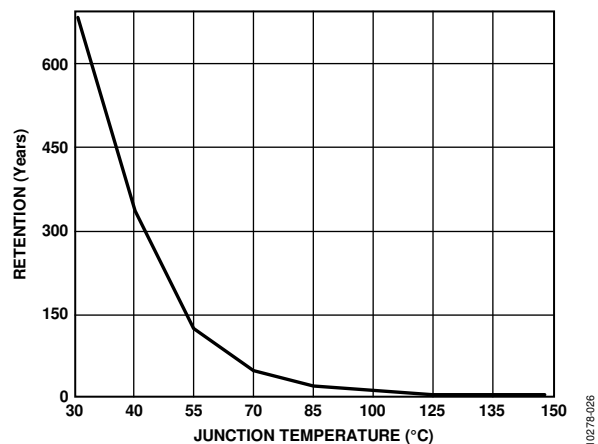

Figure 26. Flash Memory Retention

Flash Memory Test

Turn to Page 3 (DIN = 0x8003), and then set GLOB_CMD[2] = 1 (DIN = 0x8204, DIN = 0x8300) to run a checksum test of the internal flash memory, which compares a factory programmed value with the current sum of the same memory locations. The result of this test loads into SYS_E_FLAG[6]. Turn to Page 0 (DIN = 0x8000) and use DIN = 0x0800 to read SYS_E_FLAG.

GENERAL-PURPOSE I/O

There are four general-purpose I/O pins: DIO1, DIO2, DIO3, and DIO4. The FNCTIO_CTRL register controls the basic function of each I/O pin. Each I/O pin only supports one function at a time. In cases where a single pin has two different assignments, the enable bit for the lower priority function automatically resets to zero and is disabled. The priority is (1) data-ready, (2) sync clock input, (3) alarm indicator, and (4) general-purpose, where 1 identifies the highest priority and 4 indicates the lowest priority.

Table 150. FNCTIO_CTRL (Page 3, Base Address = 0x06)

Bits	Description (Default = 0x000D)
[15:12]	Not used
11	Alarm indicator: 1 = enabled, 0 = disabled
10	Alarm indicator polarity: 1 = positive, 0 = negative
[9:8]	Alarm indicator line selection: 00 = DIO1, 01 = DIO2, 10 = DIO3, 11 = DIO4
7	Sync clock input enable: 1 = enabled, 0 = disabled
6	Sync clock input polarity: 1 = rising edge, 0 = falling edge
[5:4]	Sync clock input line selection: 00 = DIO1, 01 = DIO2, 10 = DIO3, 11 = DIO4
3	Data-ready enable: 1 = enabled, 0 = disabled
2	Data-ready polarity: 1 = positive, 0 = negative
[1:0]	Data-ready line selection: 00 = DIO1, 01 = DIO2, 10 = DIO3, 11 = DIO4

Data-Ready Indicator

FNCTIO_CTRL[3:0] provide some configuration options for using one of the DIOx pins as a data-ready indicator signal, which can drive a processor interrupt control line. The factory default assigns DIO2 as a positive polarity, data-ready signal. Use the following sequence to change this assignment to DIO1 with a negative polarity: turn to Page 3 (DIN = 0x8003) and set FNCTIO_CTRL[3:0] = 1000 (DIN = 0x8608, then DIN = 0x8700). The timing jitter on the data-ready signal is $\pm 1.4 \mu\text{s}$.

Input Sync/Clock Control

FNCTIO_CTRL[7:4] provide some configuration options for using one of the DIOx pins as an input synchronization signal for sampling inertial sensor data. For example, use the following sequence to establish DIO4 as a positive polarity, input clock pin and keep the factory default setting for the data-ready function: turn to Page 3 (DIN = 0x8003) and set FNCTIO_CTRL[7:0] = 0xFD (DIN = 0x86FD, then DIN = 0x8700). Note that this command also disables the internal sampling clock, and no data sampling takes place without the input clock signal. When selecting a clock input frequency, consider the 330 Hz sensor bandwidth, because under sampling the sensors can degrade noise and stability performance.

General-Purpose I/O Control

When FNCTIO_CTRL does not configure a DIOx pin, GPIO_CTRL provides register controls for general-purpose use of the pin. GPIO_CTRL[3:0] provides input/output assignment controls for each pin. When the DIOx pins are inputs, monitor their levels by reading GPIO_CTRL[7:4]. When the DIOx pins are used as outputs, set their levels by writing to GPIO_CTRL[7:4]. For example, use the following sequence to set DIO1 and DIO3 as high and low output pins, respectively, and set DIO2 and DIO4 as input pins. Turn to Page 3 (DIN = 0x8003) and set GPIO_CTRL[7:0] = 0x15 (DIN = 0x8815, then DIN = 0x8900).

Table 151. GPIO_CTRL (Page 3, Base Address = 0x08)

Bits	Description (Default = 0x00X0) ¹
[15:8]	Don't care
7	General-Purpose I/O Pin 4 (DIO4) data level
6	General-Purpose I/O Pin 3 (DIO3) data level
5	General-Purpose I/O Pin 2 (DIO2) data level
4	General-Purpose I/O Pin 1 (DIO1) data level
3	General-Purpose I/O Pin 4 (DIO4) direction control (1 = output, 0 = input)
2	General-Purpose I/O Pin 3 (DIO3) direction control (1 = output, 0 = input)
1	General-Purpose I/O Pin 2 (DIO2) direction control (1 = output, 0 = input)
0	General-Purpose I/O Pin 1 (DIO1) direction control (1 = output, 0 = input)

¹ GPIO_CTRL[7:4] reflects levels on the DIOx pins and does not have a default setting

POWER MANAGEMENT

The SLP_CNT register (see Table 152) provides controls for both power-down mode and sleep mode. The trade-off between power-down mode and sleep mode is between idle power and recovery time. Power-down mode offers the best idle power consumption but requires the most time to recover. Also, all volatile settings are lost during power-down but are preserved during sleep mode.

For timed sleep mode, turn to Page 3 (DIN = 0x8003), write the amount of sleep time to SLP_CNT[7:0] and then, set SLP_CNT[8] = 1 (DIN = 0x9101) to start the sleep period. For a timed power-down period, change the last command to set SLP_CNT[9] = 1 (DIN = 0x9102). To power down or sleep for an indefinite period, set SLP_CNT[7:0] = 0x00 first, then set either SLP_CNT[8] or SLP_CNT[9] to 1. Note that the command takes effect when the $\overline{\text{CS}}$ pin goes high. To awaken the device from sleep or power-down mode, use one of the following options to restore normal operation:

- Assert $\overline{\text{CS}}$ from high to low.
- Pulse $\overline{\text{RST}}$ low, then high again.
- Cycle the power.

For example, set SLP_CNT[7:0] = 0x64 (DIN = 0x9064), then set SLP_CNT[8] = 1 (DIN = 0x9101) to start a sleep period of 100 seconds.

Table 152. SLP_CNT (Page 3, Base Address = 0x10)

Bits	Description
[15:10]	Not used
9	Power-down mode
8	Normal sleep mode
[7:0]	Programmable time bits; 1 sec/LSB; 0x00 = indefinite

If the sleep mode and power-down mode bits are both set high, the normal sleep mode (SLP_CNT[8]) bit takes precedence.

General-Purpose Registers

The USER_SCR_x registers (see Table 153, Table 154, Table 155, and Table 156) provide four 16-bit registers for storing data.

Table 153. USER_SCR_1 (Page 2, Base Address = 0x74)

Bits	Description
[15:0]	User-defined

Table 154. USER_SCR_2 (Page 2, Base Address = 0x76)

Bits	Description
[15:0]	User-defined

Table 155. USER_SCR_3 (Page 2, Base Address = 0x78)

Bits	Description
[15:0]	User-defined

Table 156. USER_SCR_4 (Page 2, Base Address = 0x7A)

Bits	Description
[15:0]	User-defined

Real-Time Clock Configuration/Data

The VDDRTC power supply pin (see Table 6, Pin 23) provides a separate supply for the real-time clock (RTC) function. This enables the RTC to keep track of time, even when the main supply (VDD) is off. Configure the RTC function by selecting one of two modes in CONFIG[0] (see Table 107). The real-time clock data is available in the TIME_MS_OUT register (see Table 157), TIME_DH_OUT register (see Table 158), and TIME_YM_OUT register (see Table 159). When using the elapsed timer mode, the time data registers start at 0x0000 when the device starts up (or resets) and begin keeping time in a manner that is similar to a stopwatch.

When using the clock/calendar mode, write the current time to the real-time registers in the following sequence: seconds (TIME_MS_OUT[5:0]), minutes (TIME_MS_OUT[13:8]), hours (TIME_DH_OUT[5:0]), day (TIME_DH_OUT[12:8]), month (TIME_YM_OUT[3:0]), and year (TIME_YM_OUT[14:8]). The updates to the timer do not become active until there is a successful write to the TIME_YM_OUT[14:8] byte. The real-time clock registers reflect the newly updated values only after the next seconds tick of the clock that follows the write to TIME_YM_OUT[14:8] (year). Writing to TIME_YM_OUT[14:8] activates all timing values; therefore, always write to this location last when updating the timer, even if the year information does not require updating.

Write the current time to each time data register after setting CONFIG[0] = 1 (DIN = 0x8003, DIN = 0x8A01). Note that CONFIG[1] provides a bit for managing daylight savings time. After the CONFIG and TIME_xx_OUT registers are configured, set GLOB_CMD[3] = 1 (DIN = 0x8003, DIN = 0x8208, DIN = 0x8300) to back up these settings in flash, and use a separate 3.3 V source to supply power to the VDDRTC function. Note that access to time data in the TIME_xx_OUT registers requires normal operation (VDD = 3.3 V and full startup), but the timer function only requires that VDDRTC = 3.3 V when the rest of the ADIS16480 is turned off.

Table 157. TIME_MS_OUT (Page 0, Base Address = 0x78)

Bits	Description
[15:14]	Not used
[13:8]	Minutes, binary data, range = 0 to 59
[7:6]	Not used
[5:0]	Seconds, binary data, range = 0 to 59

Table 158. TIME_DH_OUT (Page 0, Base Address = 0x7A)

Bits	Description
[15:13]	Not used
[12:8]	Day, binary data, range = 1 to 31
[7:6]	Not used
[5:0]	Hours, binary data, range = 0 to 23

Table 159. TIME_YM_OUT (Page 0, Base Address = 0x7C)

Bits	Description
[15]	Not used
[14:8]	Year, binary data, range = 0 to 99, relative to 2000 A.D.
[7:4]	Not used
[3:0]	Month, binary data, range = 1 to 12

APPLICATIONS INFORMATION

MOUNTING TIPS

For best performance, follow these simple rules when installing the ADIS16480 into a system:

1. Eliminate opportunity for translational force (x-axis and y-axis direction, see Figure 6) application on the electrical connector.
2. Isolate mounting force to the four corners, on the part of the package surface that surrounds the mounting holes.
3. Use uniform mounting forces on all four corners. The suggested torque setting is 40 inch-ounces (0.285 N-m).

These three rules help prevent nonuniform force profiles, which can warp the package and introduce bias errors in the sensors. Figure 27 provides an example that leverages washers to set the package off the mounting surface and uses 2.85 mm pass-through holes and backside washers/nuts for attachment. Figure 28 and Figure 29 provide some details for mounting hole and connector alignment pin drill locations. For more information on mounting the ADIS16480, see the AN-1295 Application Note.

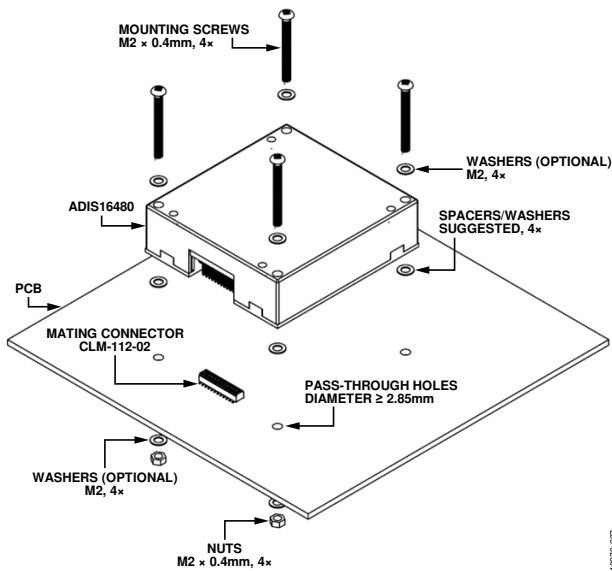
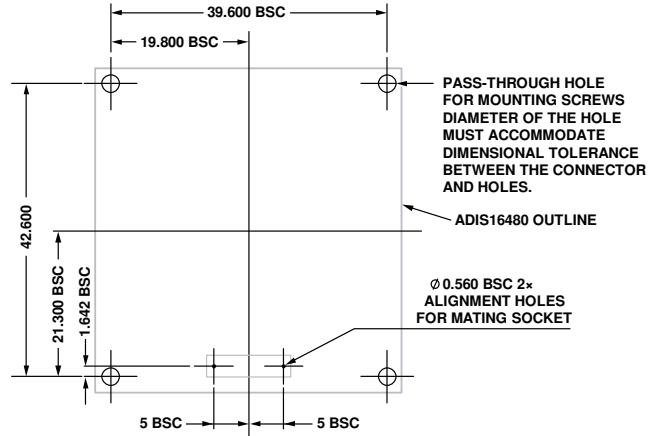

Figure 27. Mounting Example



- NOTES
 1. ALL DIMENSIONS IN mm UNITS.
 2. THE CONNECTOR FACES DOWN AND ARE NOT VISIBLE FROM THIS VIEW.

Figure 28. Suggested PCB Layout Pattern, Connector Down

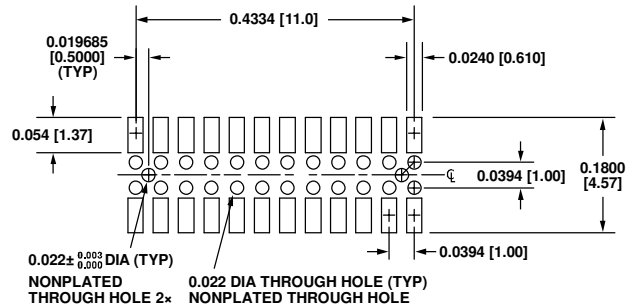

Figure 29. Suggested Layout and Mechanical Design When Using Samtec P/N CLM-112-02-G-D-A for the Mating Connector

EVALUATION TOOLS

Breakout Board, ADIS16IMU1/PCB

The ADIS16IMU1/PCBZ (sold separately) provides a breakout board function for the ADIS16480, which means that it provides access to the ADIS16480 through larger connectors that support standard 1 mm ribbon cabling. It also provides four mounting holes for attachment of the ADIS16480 to the breakout board. For more information on the ADIS16IMU1/PCBZ, see www.analog.com/ADIS16IMU1/PCBZ.

PC-Based Evaluation, EVAL-ADIS2

Use the EVAL-ADIS2 and ADIS16IMU1/PCBZ to evaluate the ADIS16480 on a PC-based platform.

POWER SUPPLY CONSIDERATIONS

The ADIS16480 has approximately ~24 μF of capacitance across the VDD and GND pins. While this capacitor bank provides a large amount of localized filtering, it also presents an opportunity for excessive charging current when the VDD voltage ramps too quickly. Use the following relationship to help determine the appropriate VDD voltage profile, with respect to any current limit functions that can cause the power supply to lose regulation and potentially introduce unsafe conditions for the ADIS16480.

$$i(t) = C \frac{dV}{dt}$$

In addition to managing the initial voltage ramp, take note of the transient current demand that the ADIS16480 requires during its start-up/self-initialization process. Once VDD reaches 2.85 V, the ADIS16480 begins its start-up process. Figure 30 offers a broad perspective that communicates when to expect the spikes in current, while Figure 31 provides more detail on the current/time behavior during the peak transient condition, which typically occurs approximately 350 ms after VDD reaches 2.85 V. In Figure 31, notice that the peak current approaches 600 mA and the transient condition lasts for approximately 1.75 ms.

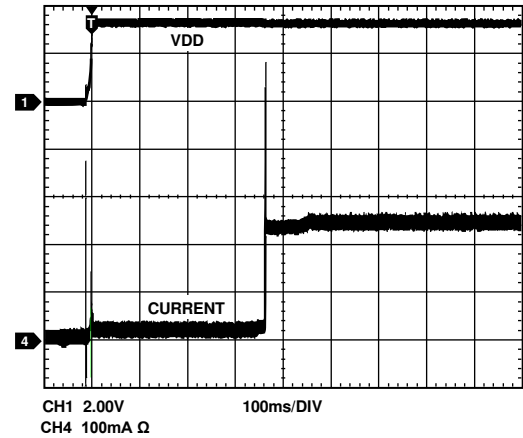

Figure 30. Transient Current Demand, Start-up

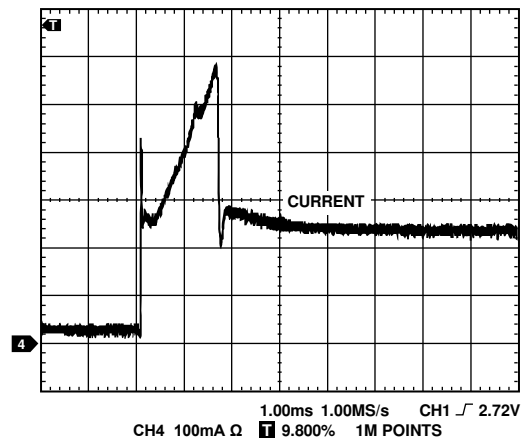

Figure 31. Transient Current Demand, Peak Demand

X-RAY SENSITIVITY

Exposure to high dose rate X-rays, such as those in production systems that inspect solder joints in electronic assemblies, may affect accelerometer bias errors. For optimal performance, avoid exposing the ADIS16480 to this type of inspection.

OUTLINE DIMENSIONS

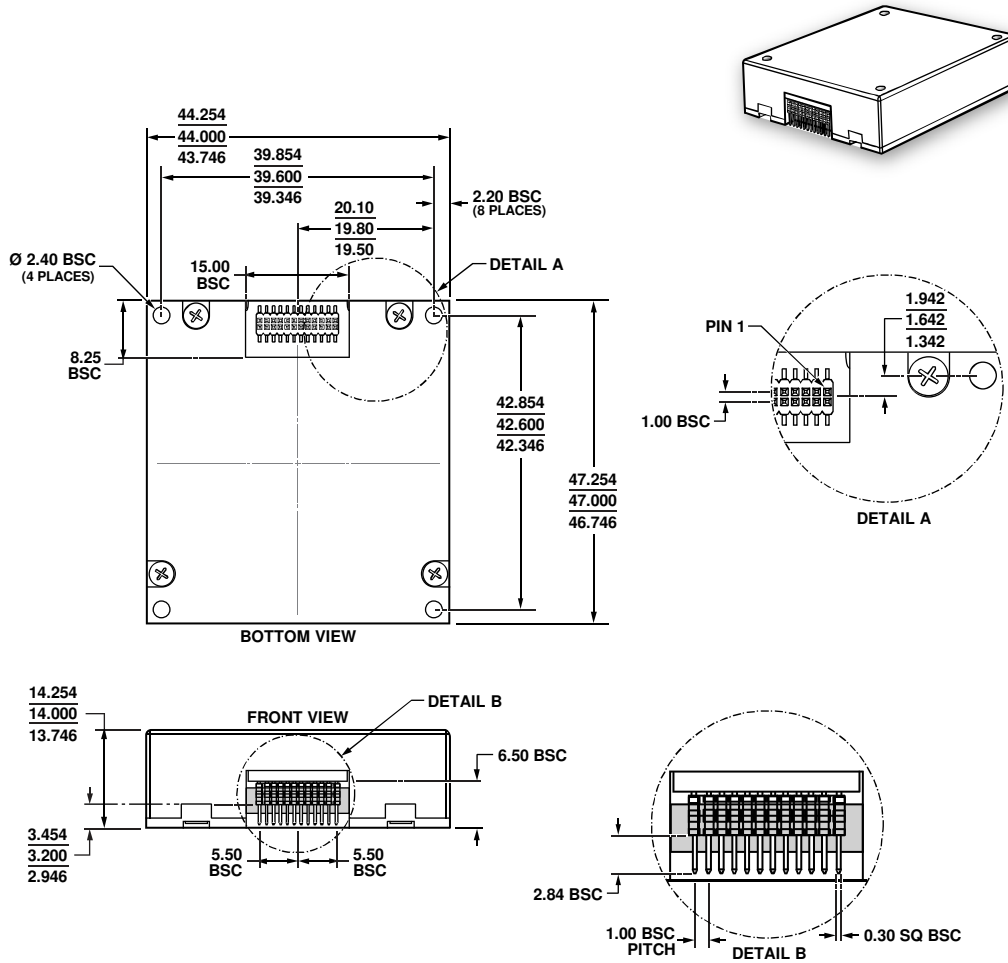

Figure 32. 24-Lead Module with Connector Interface [MODULE]
(ML-24-6)
Dimensions shown in millimeters

12-07-2012.E

ORDERING GUIDE

Model ¹	Temperature Range	Package Description	Package Option
ADIS16480BMLZ	-40°C to +105°C	24-Lead Module with Connector Interface [MODULE]	ML-24-6

¹ Z = RoHS Compliant Part.