

REVISIONS					
REV	ECO	DESCRIPTION	DATE	BY	APPR
A1	-	FIRST RELEASE	APR.13,2016	Drack	Tommy
A2	-	UPDATE DRAWING	Oct.30,2017	White	Tommy

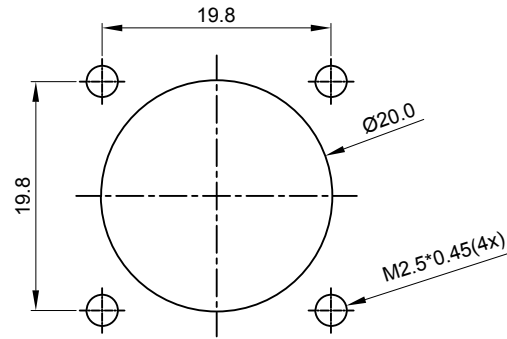

MOUNTING HOLE

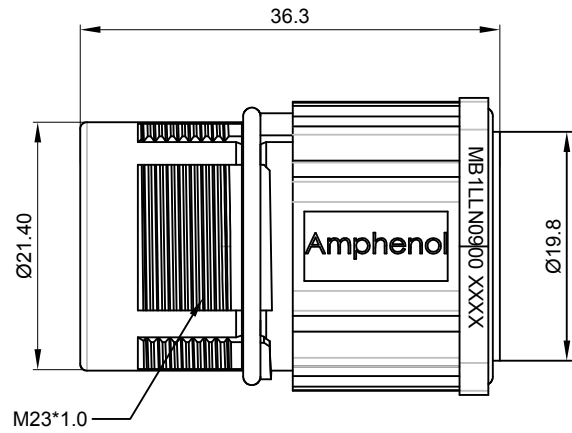
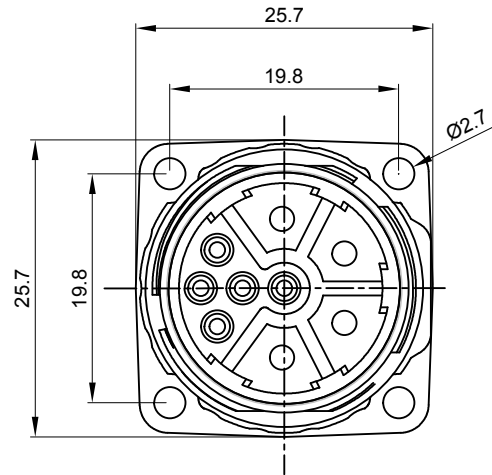
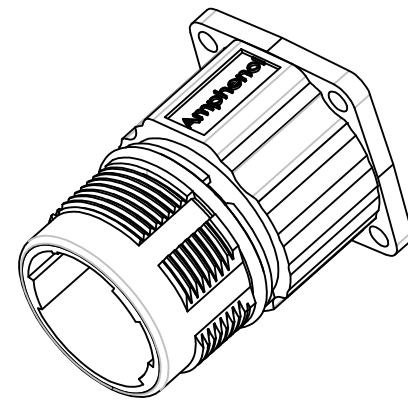

NOTES: UNLESS OTHERWISE SPECIFIED

- MATERIAL:
INSULATION INSERT: PA66, UL94 V0
SEAL: VITON
HOUSING BODY: ZINC DIE CAST, NICKEL PLATED
CONTACT: COPPER ALLOY, GOLD PLATED
- SPECIFICATIONS:
2.1 CURRENT RATING: SIGNAL: 10 AMPS
POWER: 30AMPS
2.2 VOLTAGE RATING: SIGNAL: 250V AC/DC
POWER: 630V AC/DC
2.3 CONTACT RESISTANCE: SIGNAL: <5 mOHMS
POWER: <3 mOHMS
2.4 OPERATING TEMPERATURE: -20°C TO +130°C
2.5 DIELECTRIC WITHSTANDING VOLTAGE: LESS THAN 2 MILLIAMPS CURRENT LEAKAGE @ SIGNAL: 2500VOLTS AC.
POWER: 6000 VOLTS AC.
2.6 DEGREE OF PROTECTION: IP67 (MATED CONDITION)
2.7 DEGREE OF POLLUTION: 3 PER UL840
2.8 OVERVOLTAGE CATEGORY: III PER UL840
2.9 MATING CYCLE DURABILITY: >500 CYCLES
2.10 RoHS COMPLIANT

3. ALL DIMENSIONS ARE FOR REFERENCE USE ONLY.

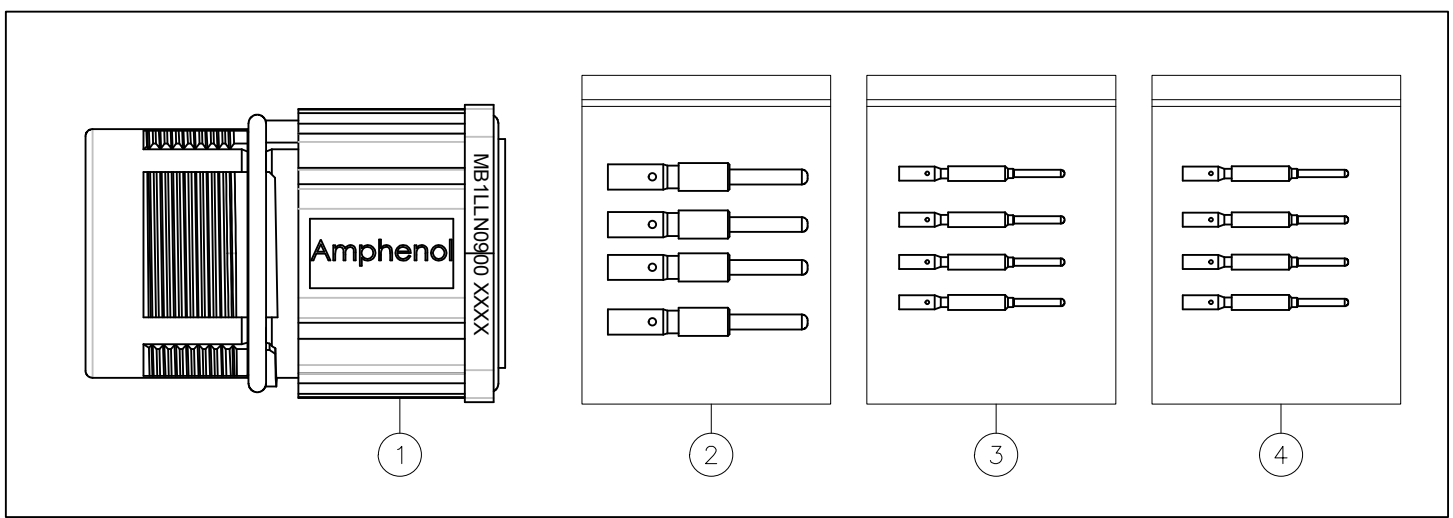

QUANTITY	PART NUMBER	DESCRIPTION	ITEM
5	SC000146	CONTACT, PIN, Ø1.0mm ,Crimp 28~24AWG	4
5	SC000035	CONTACT, PIN, Ø1.0mm ,Crimp 22~18AWG	3
4	SC000036	CONTACT, PIN, Ø2.0mm ,Crimp 14~18AWG	2
1	MB1LLN0900	CONNECTOR	1

SIGNATURES			DATE
DRAWN: White		Oct.30,2017	
CHECKED: Tod		Oct.30,2017	
ENGINEER:			
APPROVAL: Tommy		Oct.30,2017	
CUSTOMER:			
THIS DRAWING IS SUPPLIED FOR INFORMATION ONLY. DESIGN FEATURES, SPECIFICATIONS AND PERFORMANCE DATA SHOWN HEREON ARE THE PROPERTY OF THE AMPHENOL CORPORATION. NO RIGHTS OF REPRODUCTION ARE IMPLIED. ALL DIMENSIONS ARE SUBJECT TO NORMAL MANUFACTURING VARIATIONS.			
SIZE: B	TYPE: C-	DWG NO: MB1LLN0900-KIT	REVISION: A2
SCALE: NONE		SHEET 1 OF 1	

TITLE: KIT;M23B,REC.,STR,9POS(4+5),FLANGE MOUNT,EXTENSION
DWG NO: MB1LLN0900-KIT
REV: A2
SH: 1
OF: 1