

Description

The E-T-A power distribution system SVS02 is designed to accommodate the electronic circuit breaker series ESS20-003 or electronic circuit protector ESX10. It distributes the current supplied by a switch mode power supply up to 40 A to 4, 8, 12 or 16 channels. Input connections are via screw terminals. The individual circuit breakers can be plugged in. Loads are connected via spring-loaded screwless terminals. The power distribution includes integral wiring of the signalisation of the individual channels which can be combined to a group signal. The SVS02 can be snapped onto a DIN symmetrical rail.

- Suitable for**
- ESS20-003
 - ESX10-103
 - 2210-S21

Ordering information

Type

- SVS02** Power distribution system for ESS20-003
- short circuit current limited DC 24 V applications
 - max. 40 A continuous load
 - two integral circuit breakers (CB1 and CB2): overcurrent protection of group signalisation of power distribution system, red LED glashes upon trip of CB1
 - 2 insulated wire bridges Y 303 881 08 included
 - without jumpers SB-S11-P1-01-1-1A (for unused positions)

Version, max. number of circuit breakers ESS20-003 on the power distribution system

- 04** 4 channels (F1...F4)
- 08** 8 channels (F1...F8)
- 12** 12 channels (F1...F12)
- 16** 16 channels (F1...F16)

Screw terminals for power supply DC 24 V

- P310** 3 loop-through terminals (X 21) max. 10 mm² for DC 24 V (+) / DC 24 V (-) / FE functional earth

Load outputs per channel (F1 .. Fn, n = 04, 08, 12, 16)

- L50** 5 load outputs per channel, max. 8 A each
- (L+S) group output (+) internally bridged over all channels
 - (L+L) protected load output (+), per channel
 - (-) DC 24 V (-)
 - (-) DC 24 V (-)
 - (FE) functional earth

Signal outputs

- S15** 1 signal terminal (X31) for group signal, 5-pole, complete with plug-in terminal, wiring 5 x max. 2.5 mm² / without connector sleeve, max. 0.5 A:
- (+) internal +DC 24 V supply for signalisation via insulated wire bridge from (+) to (SC)
 - (SC) external supply possible +DC 24 V for signalisation
 - (S0) signal output group signalisation
 - (-) additional output DC 24 V (-)
 - (FE) additional functional earth

Control input

- E00** without control input

Fitting variants

- B10** complete with screwless spring-loaded terminals, (max. 2.5 mm², without connector sleeve) (standard)
- B20** complete with plug-in screw terminals (max. 2.5 mm², without connector sleeve)

SVS02 - 16-P310 - L50 - S15 - E00 - B10

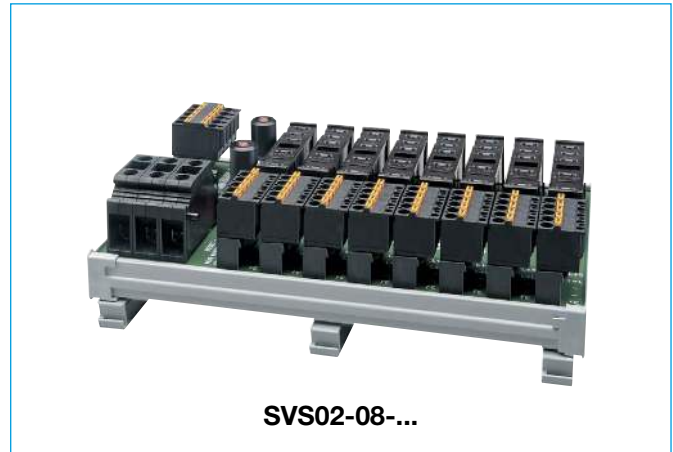

SVS02-08-...

Technical data

- Modular Power distribution system for short-circuit limited DC 24 V applications up to max. 40 A continuous load, max. voltage DC 32 V.
- Three screw terminals (max. 10 mm²/AWG 8) for:
 - DC 24 V (+) = X 21 +
 - DC 24 V (-) = X 21 -
 - FE (functional earth) = X 21 FE
 for connecting the DC 24 V power supply max. 40 A
- Modular design ESS20-positions F1...F4 (..F8, ...F12 or ...F16):
 - SVS02-04 / 4 channels / F1...F4 = Kl. X1...X4
 - SVS02-08 / 8 channels / F1...F8 = Kl. X1...X8
 - SVS02-12 / 12 channels / F1...F12 = Kl. X1...X12
 - SVS02-16 / 16 channels / F1...F16 = Kl. X1...X16
- 5 load outputs per channel complete with Combicon screwless connectors, wiring 5 x max. 2.5 mm² (AWG 14)/ without connector sleeve max. 8 A:
 - (L+S) group output (+), internally bridged across all channels
 - (L+L) load output (+), per channel
 - (-) DC 24 V (-)
 - (-) DC 24 V (-)
 - (FE) functional earth
- Signal terminal (X31) for group signal complete with Combicon screwless connectors, wiring 5 x max. 2.5 mm² (AWG 14)/ without connector sleeve, max. 0.5 A (signal contact ESS20):
 - (+) internal +DC 24 V supply for signalisation of terminal X 21 + via insulated jumper from (+) to (SC), protected by CB2
 - (SC) external supply possible +DC 24 V for signalisation, protected by CB1
 - (S0) signal output group signalisation
 - (-) additional output DC 24 V (-)
 - (FE) additional functional earth
- Selective overcurrent protection CB1 and CB2 for group signalisation of the power distribution system, red LED blinks after CB1 has tripped (see schematic diagram). Reset of circuit breakers: momentarily press red actuator button
- Protection class to: IP20
- Insulation co-ordination to IEC 60934: 0.5 kV / pollution degree 2
- Dielectric strength AC 500 V
- Temperature range: 0...50 °C (without condensation)
- for DIN symmetrical rail mounting EN 50022 - 35 x 7.5
- Dimensions: see dimensional drawing

Dimensions SVS02-16

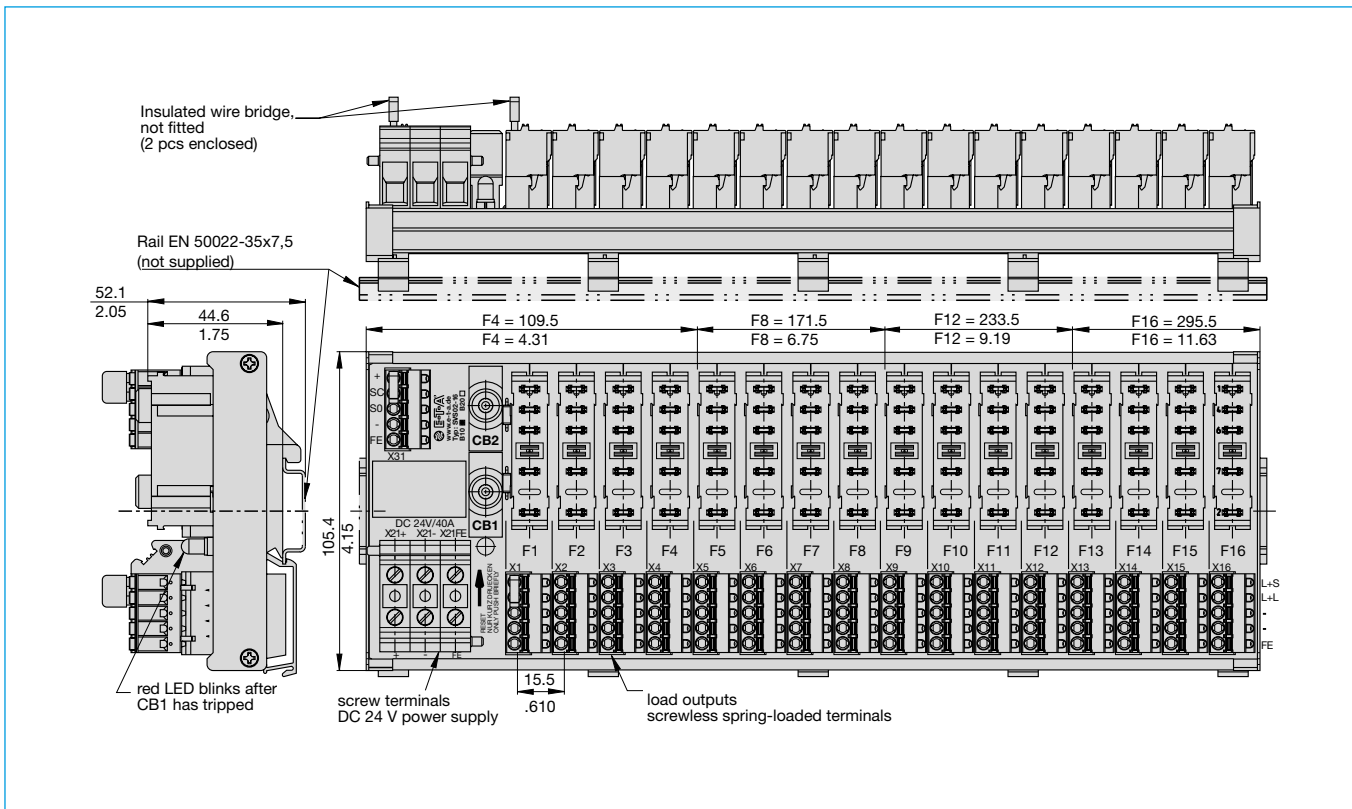

This is a metric design and millimeter dimensions take precedence ($\frac{\text{mm}}{\text{inch}}$)

Schematic diagram SVS02-(n) n = 04, 08, 12, 16

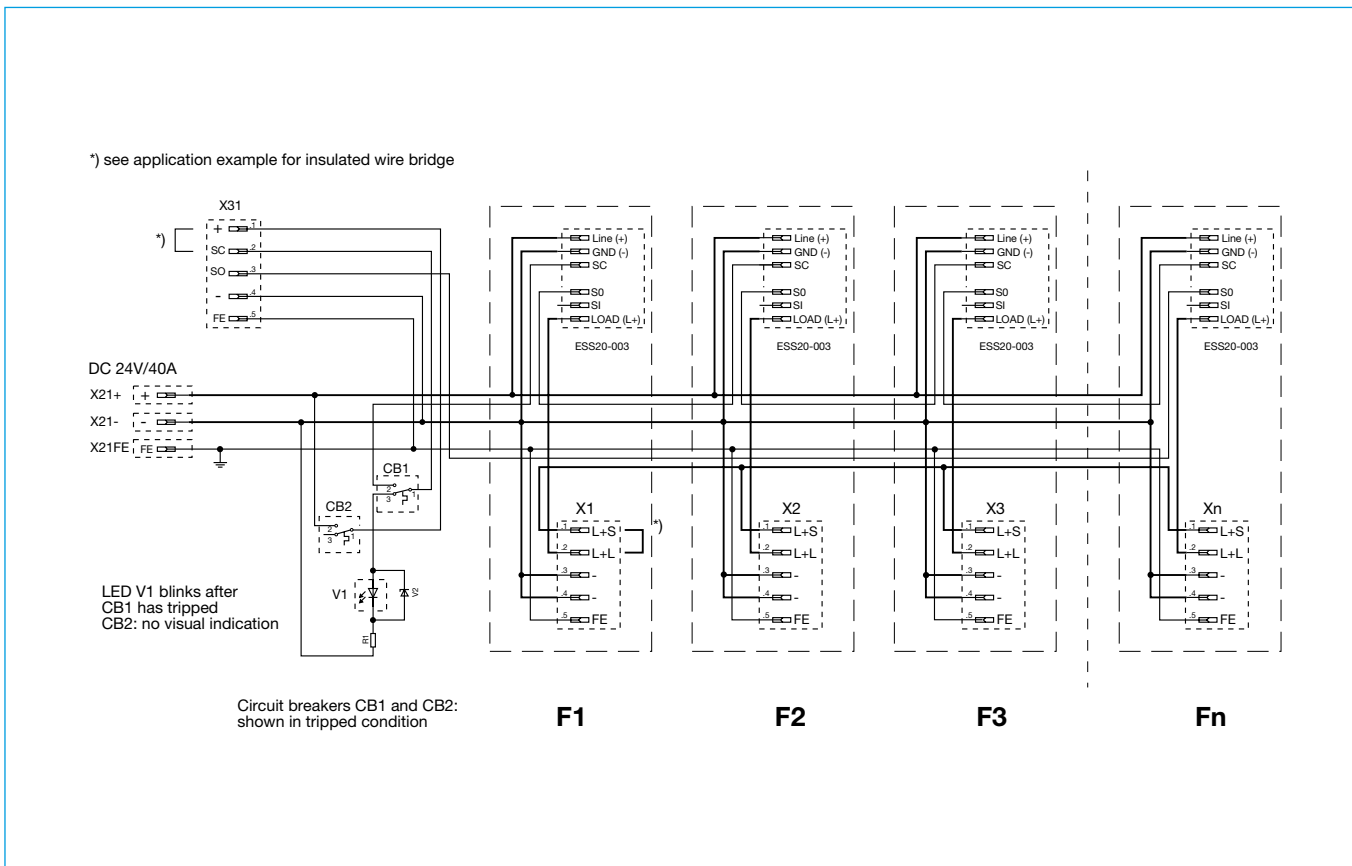

6

Dimensions SVS02-04, fitted with ESS20-003

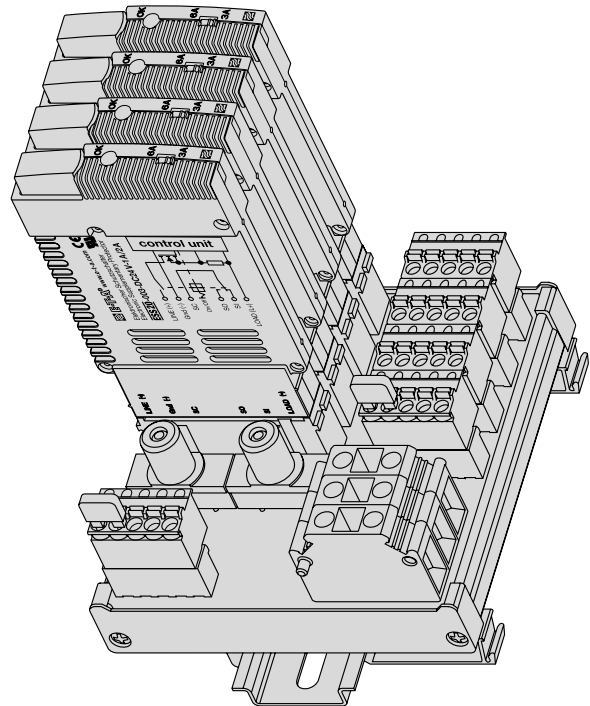
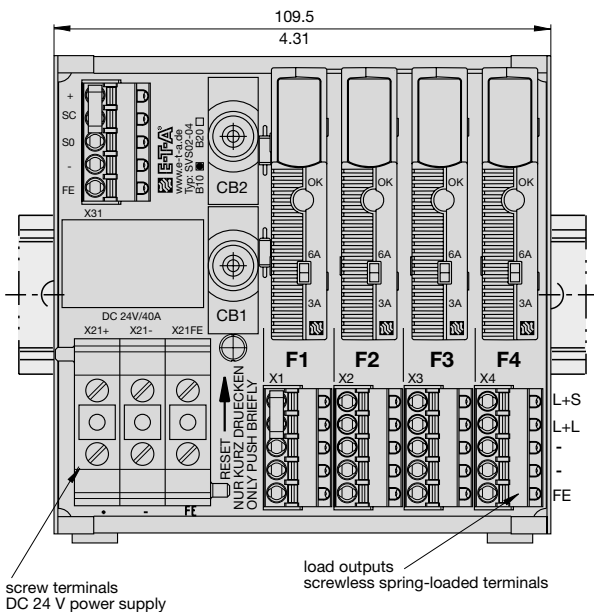
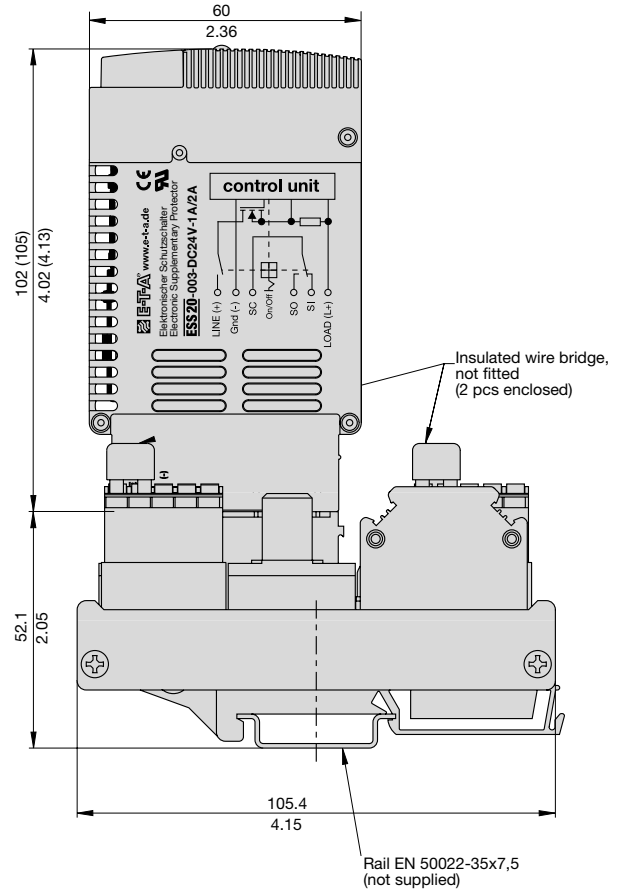
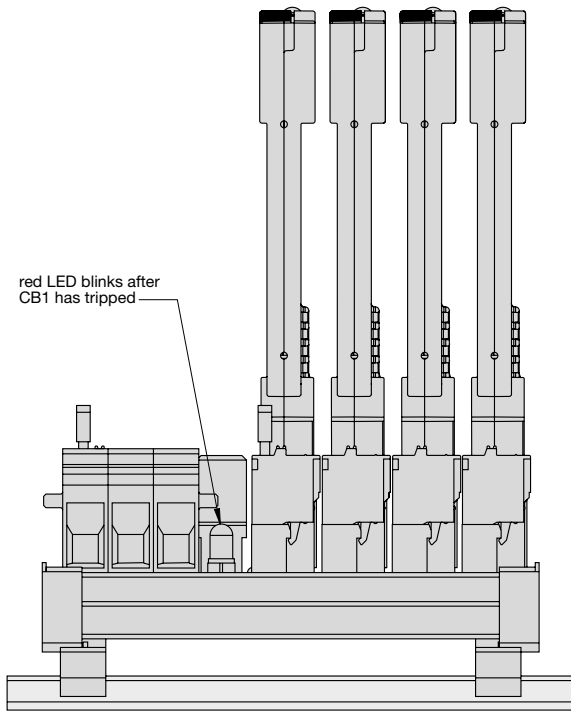

This is a metric design and millimeter dimensions take precedence ($\frac{mm}{inch}$)

Dimensions SVS02-04, fitted with ESX10-103

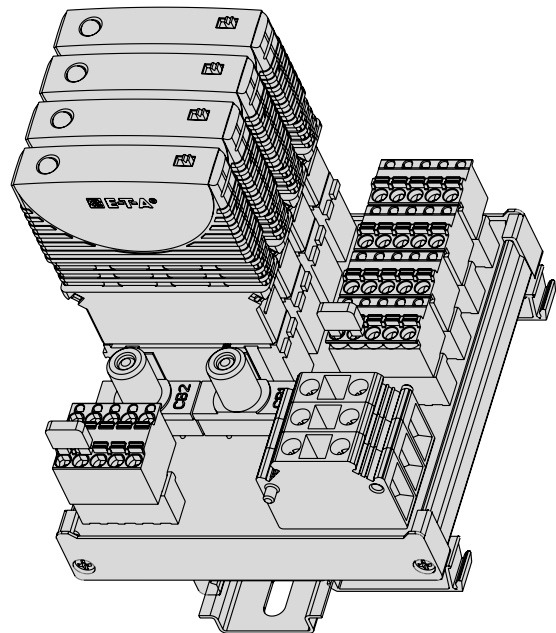
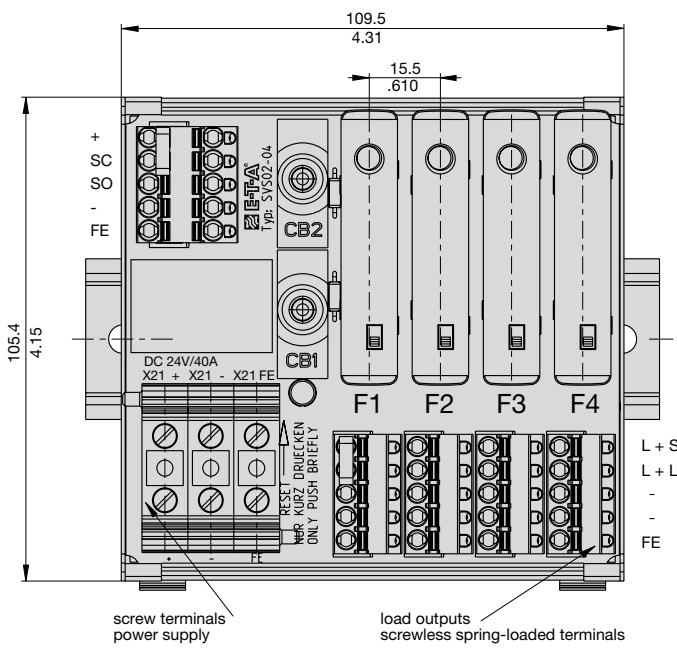
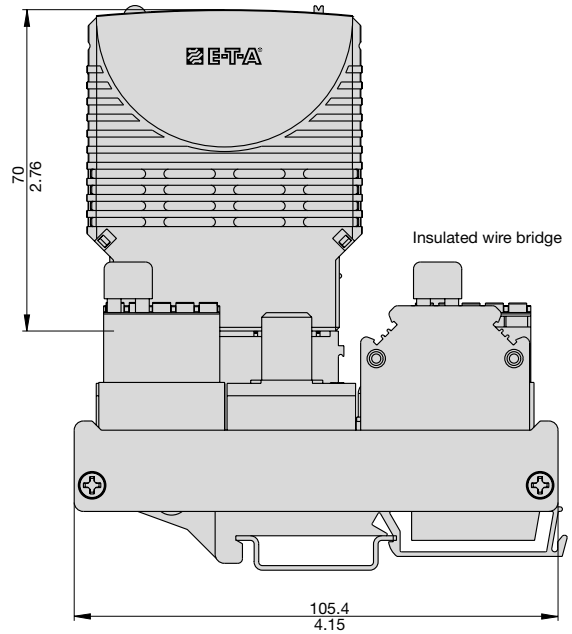
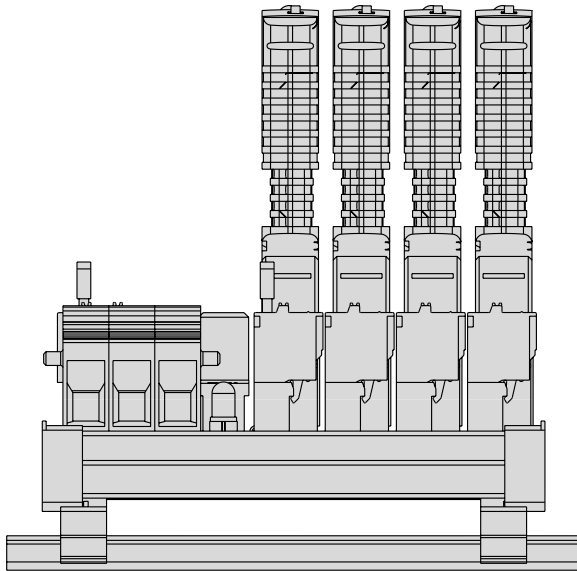

6

Application example for jumper to replace

The signalling pathway of the group signalisation is as follows:

- feed-in of +DC 24 V potential in (SC = terminal 31.2)
- via in-built overcurrent protection CB1
- via all signal contacts of the fitted circuit breakers type ESS20-003
- back to signal output of group signalisation (S0 = terminal 31.3)

In operating condition (i.e. all circuit breakers plugged in and functional) the signalling pathway (SC) to (S0) is closed.

If the distribution rail is not completely fitted with ESS20-003, the open pathway (SC) to (S0) may be closed by means of a jumper type SB-S11-P1-01-1-1A

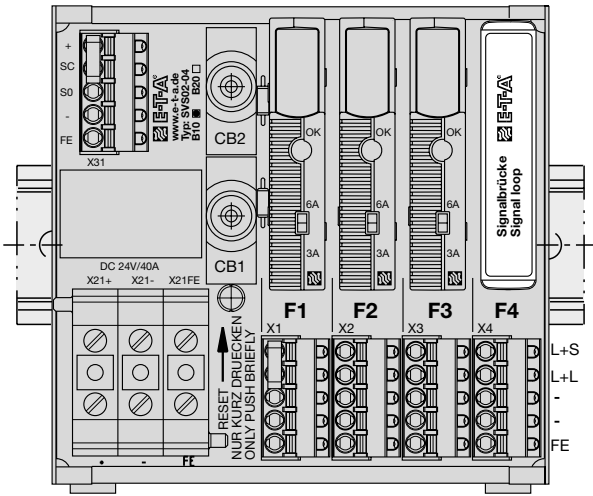

Application example for insulated wire bridge

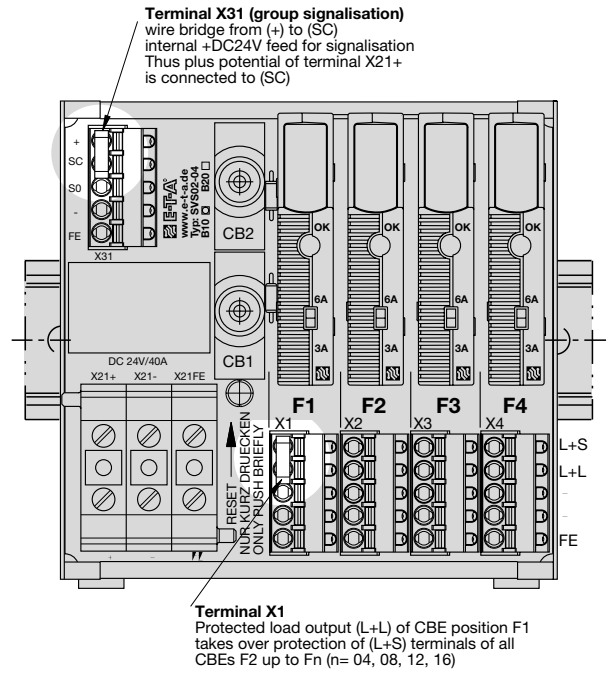

Accessories

Jumper SB-S11-P1-01-1-1A

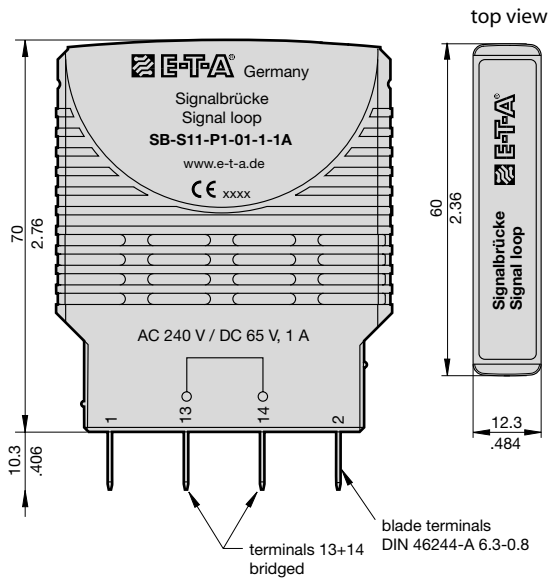

Insulated wire bridge Y 303 881 08

Two insulated wire bridges are supplied with the power distribution system. They may be used for:

- Channel X31: internal +DC 24 V supply for signalisation wire bridge from (+) to (SC)
Signal circuit (+) to (SC) protected by CB2
Signal circuit (SC) to (S0) protected by CB1
- Channel X1: Protected load output (L+L) of CBE position F1 takes over protection of (L+S) terminals of all CBEs F2 up to Fn (n= 04, 08, 12, 16)

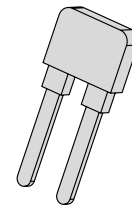

This is a metric design and millimeter dimensions take precedence ($\frac{mm}{inch}$)

All dimensions without tolerances are for reference only. In the interest of improved design, performance and cost effectiveness the right to make changes in these specifications without notice is reserved. Product markings may not be exactly as the ordering codes. Errors and omissions excepted.

