

# OBSOLETE

## Closest Alternative is AP5727FDCG-7

### ZXLD1601

---

#### ADJUSTABLE DC - DC BOOST CONVERTER WITH INTERNAL SWITCH IN SC70

---

##### DESCRIPTION

The ZXLD1601 is a PFM inductive boost converter designed to provide output voltages of up to 28V from a 2.5V to 5.5V input supply.

The ZXLD1601 includes the output switch and peak current sense resistor, and can provide up to 10mA output current at maximum output voltage. Higher current is available at lower output voltages.

Quiescent current is typically 60µA and a shutdown function is provided to reduce this current to less than 100nA in the 'off' state.

Output voltage is set to a nominal value between 26V and 28V, by an internal resistor network, but can be adjusted to lower values by external resistors, an external PWM control signal applied to the 'Enable' pin, or a combination of the two. Depending upon the control frequency, the PWM signal will provide either continuous (low ripple) or gated control. The PWM filter components are contained within the chip. Minimum output voltage is determined by the input supply.

The device is assembled in a low profile SC70-6 pin package.

##### ADVANCED FEATURES

- Internal 30V NDMOS switch, current sense and output setting resistors.
- True analogue output voltage control via PWM with internal filter

##### FEATURES

- Low profile SC70-6 pin package
- Internal PWM filter for adjustable output
- High efficiency (85% typ)
- Wide input voltage range: 2.5V to 5.5V
- Up to 250mA output current at 5V
- Low quiescent current: (60µA typ)
- 100nA maximum shutdown current
- Up to 1MHz switching frequency
- Low external component count

##### APPLICATIONS

- LCD and OLED bias
- Cellular / mobile phones
- Digital cameras
- PDAs
- LCD modules
- Varactor and PIN diode bias
- Palmtop computers

##### TYPICAL APPLICATION CIRCUIT

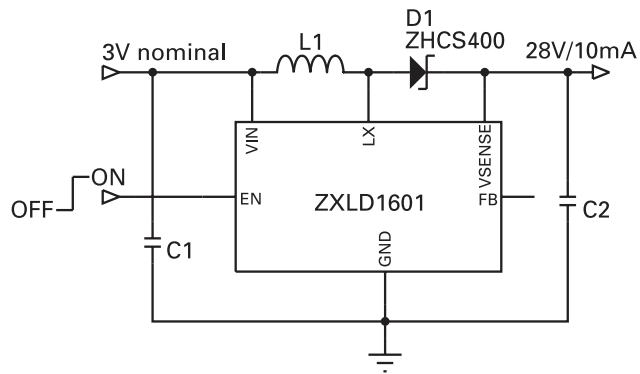

##### PINOUT

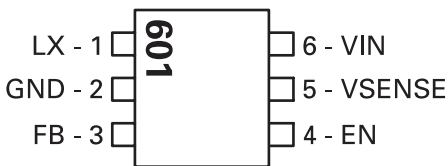

##### TOP VIEW

# OBSOLETE

## Closest Alternative is AP5727FDCG-7

### ZXLD1601

#### ABSOLUTE MAXIMUM RATINGS

(Voltages to GND unless otherwise stated)

Input voltage ( $V_{IN}$ )	7V
LX output voltage ( $V_{LX}$ )	30V
Switch output current ( $I_{LX}$ )	500mA
Power dissipation (PD)	300mW
Operating temperature ( $T_{OP}$ )	-40 to 85°C
Storage temperature ( $T_{ST}$ )	-55 to 150°C
Junction temperature ( $T_{j\ MAX}$ )	125°C

**ELECTRICAL CHARACTERISTICS:** (Test conditions:  $V_{IN}=V_{EN}=3V$ ,  $T_{AMB}=25^{\circ}C$  unless otherwise stated<sup>(1)</sup>)

Symbol	Parameter	Conditions	Min	Typ	Max	Units
$V_{IN}$	Input voltage		2.5		5.5	V
$I_{IN}$	Supply current					
	Quiescent	$V_{EN} = V_{IN}$ , $I_{LX} = 0$ , Output not switching		60	100	$\mu A$
	Shutdown	$V_{EN} = 0V$		<10	100	nA
$V_{FB}$	FB pin control voltage		0.98		1.07	V
$R_1$	Internal resistor from FB pin to GND pin			135		k $\Omega$
$R_2$	Internal resistor from FB pin to $V_{SENSE}$ pin			3.45		M $\Omega$
$f_{LX}$	Operating frequency	$L=10\mu H$ , $V_{OUT}=28V$ , 5mA load		600		kHz
$T_{OFF}$	LX output 'OFF' time		350	500		ns
$T_{ON}^{(2)}$	LX output 'ON' time				5	$\mu s$
$I_{LXpk}$	Switch peak current limit	$L=10\mu H$ , $V_{OUT}=28V$ , 5mA load		320		mA
$R_{LX}$	Switch 'On' resistance			1.75		$\Omega$
$I_{LX(leak)}$	Switch leakage current	$V_{LX}=20V$			1	$\mu A$
$V_{OUT}$	Controller default output voltage	FB pin floating	26		28	V
$V_{ENH}$	EN pin high level Input voltage	Device active	1.5		$V_{IN}$	V
$V_{ENL}$	EN pin low level Input voltage	Device in shutdown			0.4	V
$I_{ENL}$	EN pin low level input current	$V_{EN}=0V$			-100	nA
$I_{ENH}$	EN pin high level input current	$V_{EN}=V_{IN}$			1	$\mu A$
$T_{EN(hold)}^{(3)}$	EN pin turn off delay	$V_{EN}$ switched from high to low		120		$\mu s$

**NOTES:**

- 1 Production testing of the device is performed at 25°C. Functional operation of the device over a -40°C to +85°C temperature range is guaranteed by design, characterization and process control.
- 2 Nominal 'on' time ( $T_{ONnom}$ ) is defined by the input voltage ( $V_{IN}$ ), coil inductance (L) and peak current ( $I_{LXpkdc}$ ) according to the expression:  
 $T_{ONnom} = (I_{LX(pkdc)} \times L / V_{IN}) + 200ns$
- 3 This is the time for which the device remains active after the EN pin has been asserted low. This delay is necessary to allow the output to be maintained during dc PWM mode operation.

# OBSOLETE

## Closest Alternative is AP5727FDCG-7

### ZXLD1601

**ELECTRICAL CHARACTERISTICS (Cont.):** (Test conditions:  $V_{IN}=V_{EN}=3V$ ,  $T_{AMB}=25^{\circ}C$  unless otherwise stated<sup>(1)</sup>)

Symbol	Parameter	Conditions	Min	Typ	Max	Units
$\Delta T/T$	PWM duty cycle range at 'EN' input for dc output voltage control	$10kHz < f < 100kHz$ , $V_{ENH} = V_{IN}$	20		100	%
fLFP	Internal PWM low pass filter cut-off frequency			4		kHz
ALPF	Filter attenuation	$f=30kHz$		52.5		dB
$\Delta T/T$ <sup>(4)</sup>	PWM duty cycle range at 'EN' input for 'gated' output voltage control	$f < 1kHz$ , $V_{ENH} = V_{IN}$	0		100	%

**NOTES:**

4 The maximum PWM signal frequency during this mode of operation should be kept as low as possible to minimize errors due to the turn-off delay

# OBSOLETE

## Closest Alternative is AP5727FDCG-7

### ZXLD1601

#### PIN DESCRIPTION

Pin No.	Name	Description
1	LX	Output of NDMOS switch
2	GND	Ground (0V)
3	FB	Feedback pin for voltage control loop Nominal voltage 1.025V
4	EN	Enable input (active high to turn on device) Also used to adjust output current by PWM signal. Connect to $V_{in}$ for permanent operation.
5	$V_{SENSE}$	Output voltage sense
6	$V_{IN}$	Input voltage (2.5V to 5.5V). Decouple with capacitor close to device.

#### BLOCK DIAGRAM

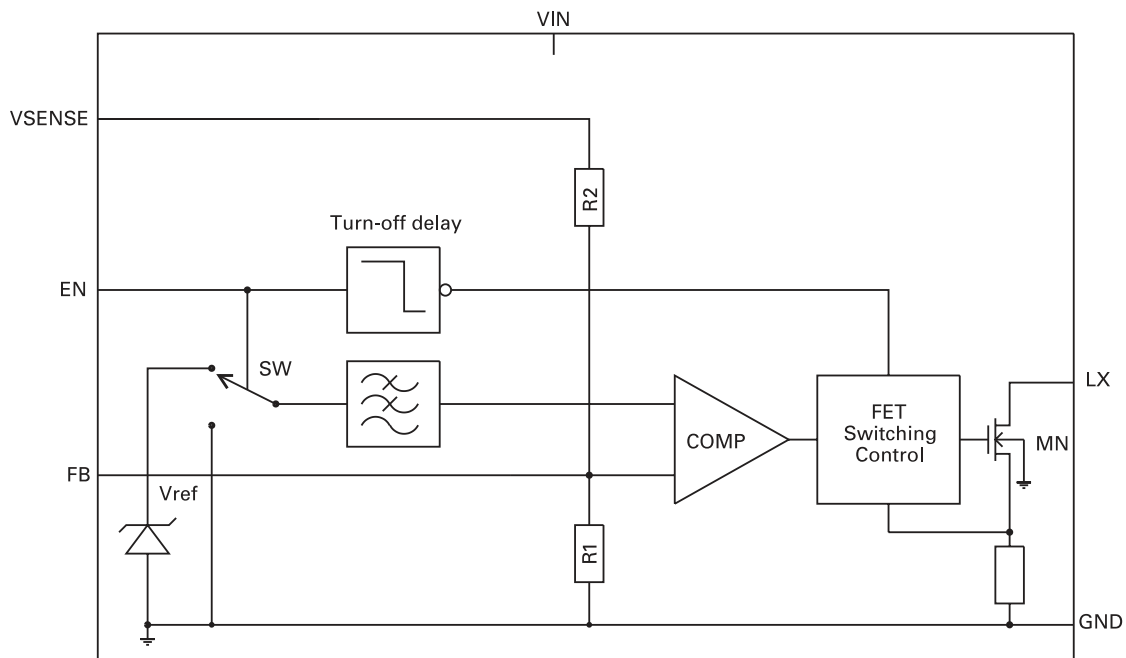

# OBSOLETE

## Closest Alternative is AP5727FDCG-7

ZXLD1601

### Device Description

The device is a PFM flyback dc-dc boost converter, working in discontinuous mode.

With reference to the chip block diagram and typical application circuit, the operation of the device is as follows:

#### Control loop

When 'EN' is high, the control circuits become active and the low side of the coil (L1) is switched to ground via NDMOS transistor (MN). The current in L1 is allowed to build up to an internally defined level (nominally 320mA) before MN is turned off. The energy stored in L1 is then transferred to the output capacitor (C2) via Schottky diode (D1). The output voltage is sensed at pin 'VSENSE' by internal resistors R1 and R2 (which may be shunted externally at pin 'FB') and compared to a reference voltage  $V_{REF}$  (1.025V nominal). A comparator senses when the output voltage is above that set by the reference and its output is used to control the 'off' time of the output switch. The control loop is self-oscillating, producing pulses of up to 5 $\mu$ s maximum duration (switch 'on'), at a frequency that varies in proportion to the output current. The feedback loop maintains a voltage of  $V_{REF}$  at the FB pin and therefore defines a maximum output voltage equal to  $V_{REF} * (R1+R2)/R1$ . The minimum 'off' time of the output switch is fixed at 0.5 $\mu$ s nominal, to allow time for the coil's energy to be dissipated before the switch is turned on again. This maintains stable and efficient operation in discontinuous mode.

#### Filtered PWM operation

The input of an internal low pass filter is switched to  $V_{REF}$  when the EN pin is high and switched to ground when the EN pin is low. The output of this filter drives the comparator within the control loop. A continuous high state on EN therefore provides a filtered voltage of value  $V_{REF}$  to the comparator. However, by varying the duty cycle of the EN signal at a suitably high frequency ( $f > 10\text{kHz}$ ), the control loop will see a voltage, that has an average value equal to the duty cycle multiplied by  $V_{REF}$ . This provides a means of adjusting the output voltage to a lower value. It also allows the device to be both turned on and adjusted with a single signal at the 'EN' pin. The output during this mode of operation will be a dc voltage equal to  $V_{REF} * (R1+R2)/R1 \times \text{duty cycle}$ .

#### Gated PWM operation

The internal circuitry of the ZXLD1601 is turned off when no signal is present on the 'EN' pin for more than 120 $\mu$ s (nominal). A low frequency signal applied to the EN pin will therefore gate the device 'on' and 'off' at the gating frequency and the duty cycle of this signal can be varied to provide an average output equal to  $V_{REF} * (R1+R2)/R1 \times \text{duty cycle}$ . For best accuracy, the gating frequency should be made as low as possible (e.g. below 1kHz), such that the turn off delay of the chip is only a small proportion of the gating period.

Further details of setting output current are given in the application notes.

# OBSOLETE

## Closest Alternative is AP5727FDCG-7

### ZXLD1601

#### TYPICAL CHARACTERISTICS

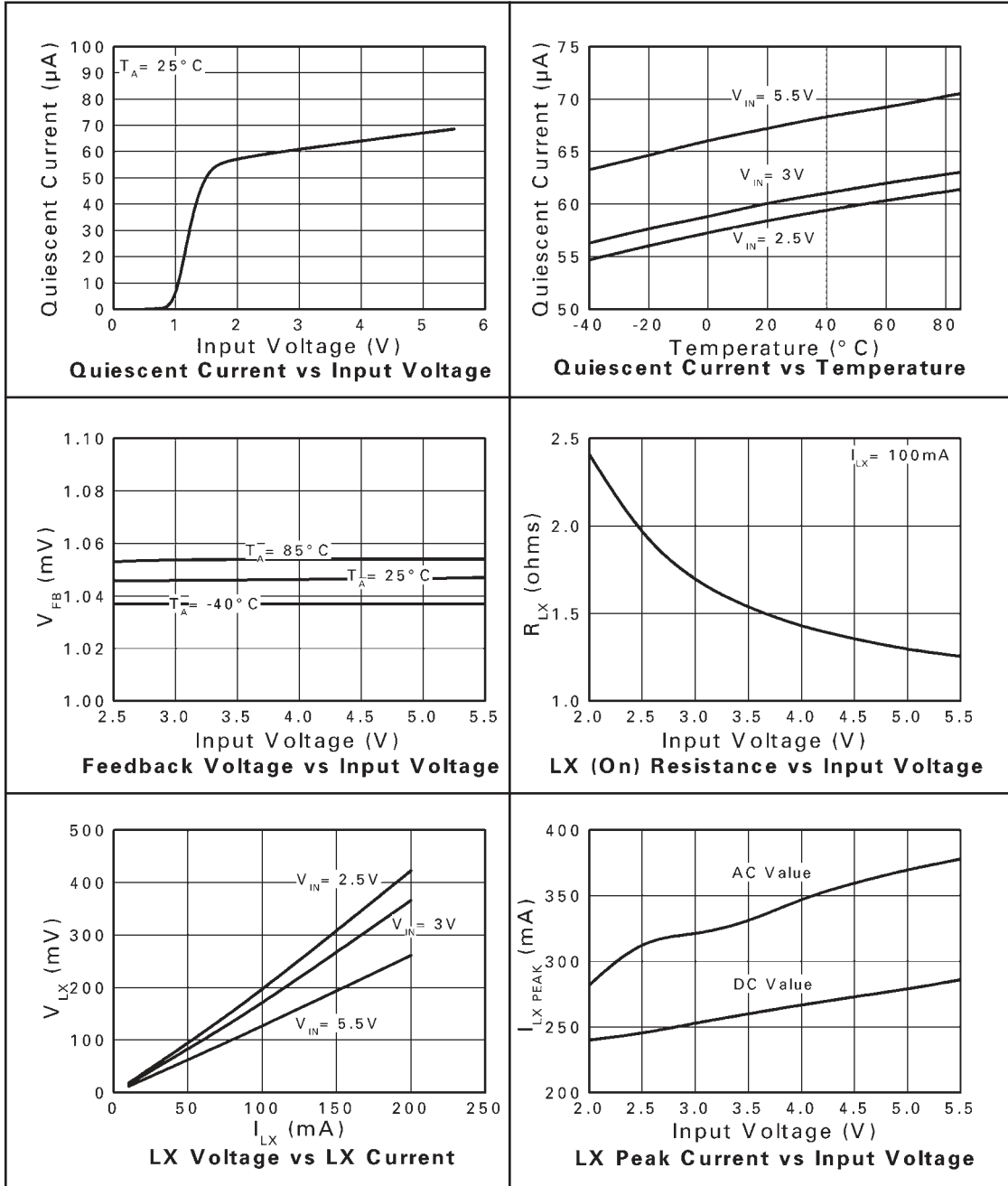

# OBSOLETE

## Closest Alternative is AP5727FDCG-7

**ZXLD1601**

### TYPICAL PERFORMANCE GRAPHS

(For typical applications circuit at  $V_{IN}=3V$ ,  $L=22\mu H$  Murata LQH32CN series,  $T_A=25^\circ C$  unless otherwise stated)

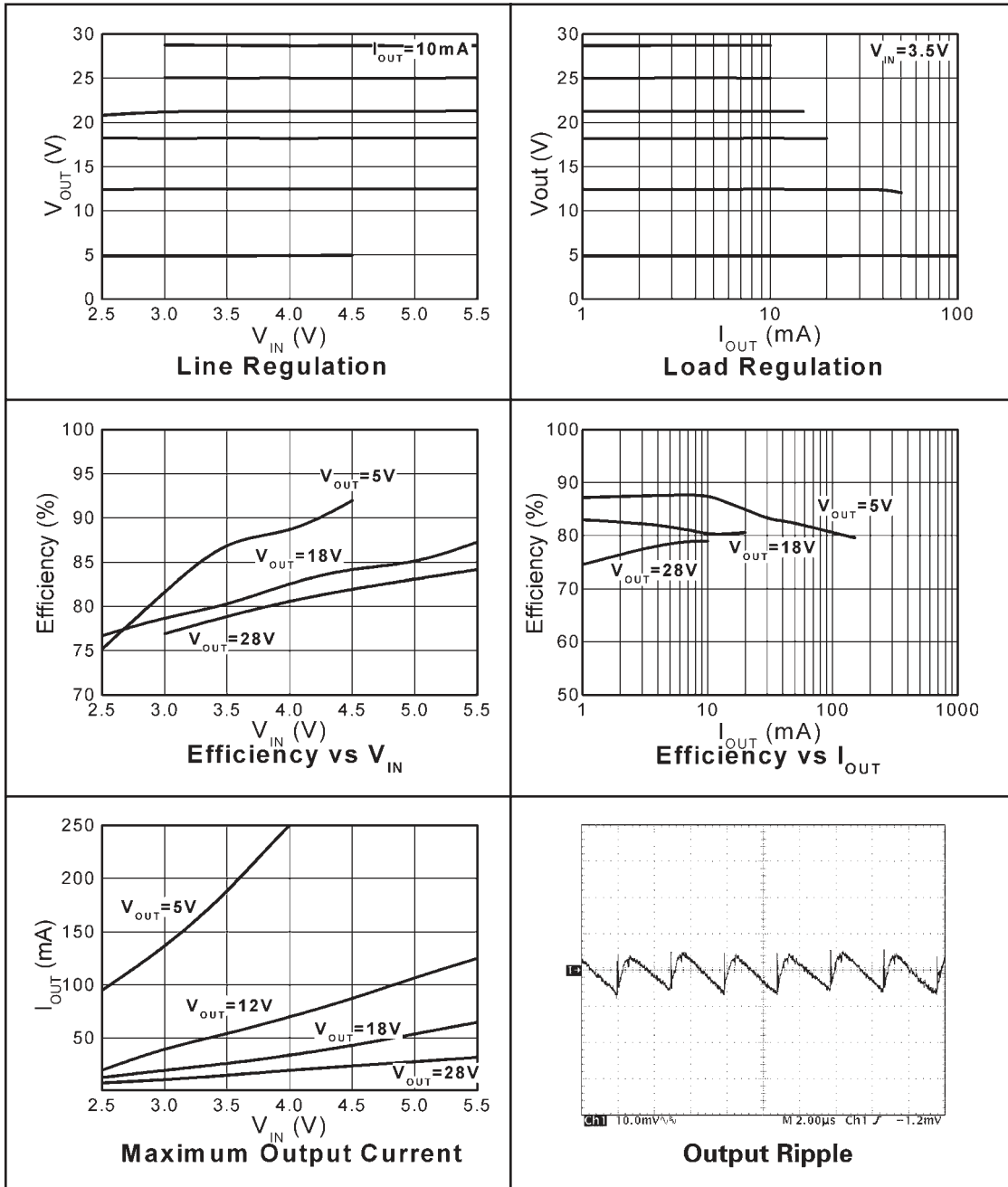

# OBSOLETE

## Closest Alternative is AP5727FDCG-7

### ZXLD1601

#### APPLICATIONS

##### Setting output voltage

When connected as shown in the typical application circuit, the ZXLD1601 will produce a nominal default output of between 26V and 28V. This is set by the internal potential divider comprising of resistors R1 and R2. (See device block diagram).

The internal potential divider network R1/R2 is accessible at the FB pin and can be shunted by means of external resistors to set different nominal output voltages. The potential divider defines output voltage according to the relationship:

$$V_{OUT} = V_{FB} \left( 1 + \frac{R2}{R1} \right)$$

where  $V_{FB} = 1.025V$ .

When using external resistors, these should be chosen with lower values than the internal resistors to minimize errors caused by the device to device variation in absolute value of the internal resistors ( $\pm 30\%$  max). The internal resistors have high values in order to minimize these errors.

Required output voltage	External resistor across R1	External resistor across R2
5V	43K $\Omega$	130K $\Omega$
12V	56K $\Omega$	487K $\Omega$
18V	43K $\Omega$	649K $\Omega$
21V	34.8K $\Omega$	649K $\Omega$
25V	27K $\Omega$	620K $\Omega$
28V	40.2K $\Omega$	1.07M $\Omega$

The following table gives suggested values for various output voltages.

Once the nominal output voltage has been set, it can be adjusted to a lower value by applying a pulse width modulated (PWM) control signal to the EN pin, using one of the two methods described below.

PWM adjustment permits the device to be turned on and the output voltage set by a single logic signal applied to the EN pin. No external resistors are required and the amplitude of the control signal is not critical, providing it conforms to the limits defined in the electrical characteristics.

##### 1) PWM output voltage adjustment (analogue mode)

During this mode of operation the device operation is continuous, providing a low ripple output voltage ( $V_{OUT}$ ) directly proportional to the duty cycle (D) of the logic signal applied to the EN pin according to the relationship:

$$V_{OUT} = D \times V_{OUT(nom)}$$

Square wave signals applied to the EN pin, for example, will turn the device on and produce a nominal regulated output of 13.5V.

The ZXLD1601 contains a timing circuit that switches the device on a few microseconds after the application of a rising edge to EN and turns it back off again nominally 120 $\mu$ s after the falling edge of EN. For continuous PWM mode operation, the frequency of the control signal must therefore be maintained above 10kHz at all times, to prevent the internal delay circuit from timing out and switching the device into standby mode. The maximum frequency applied to EN should be limited to 100kHz to minimize errors due to internal switching delays.

##### 2) PWM output voltage adjustment (gated mode)

This method of adjustment can be used in applications where the output ripple is less important than the supply current. The method of adjustment is the same as in 1) above, however, during this mode of operation, the device is gated on and off, providing an average output voltage ( $V_{OUT}$ ) directly proportional to the duty cycle (D) of the logic signal applied to the EN pin according to the relationship:

$$V_{OUT(AVG)} = D \times V_{OUT(nom)}$$

The ripple on this voltage will be determined by the size of the output capacitor.

The output voltage can be adjusted all the way down to the input voltage by either method of PWM control, but for best results, the duty cycle range should be kept within the specified range. Lower duty cycles will result in increased output ripple and non-linearity in the relationship between duty cycle and output voltage. If a greater control range is required, the nominal output can be reduced by the use of external resistors before the PWM signal is applied.

##### Minimizing output voltage ripple

For applications requiring lower output ripple it may be necessary to add a small ceramic capacitor in parallel with R2. A value of 4.7pF is suitable for most output ranges.



# OBSOLETE

## Closest Alternative is AP5727FDCG-7

### ZXLD1601

#### Capacitor selection

A ceramic capacitor grounded close to the GND pin of the package is recommended at the output of the device. Surface mount types offer the best performance due to their lower inductance. A minimum value of 0.22 $\mu$ F is advised, although higher values will lower switching frequency and improve efficiency especially at lower load currents. A higher value will also minimize ripple when using the device to provide an adjustable dc output current.

A good quality, low ESR capacitor should also be used for input decoupling, as the ESR of this capacitor is effectively in series with the source impedance and lowers overall efficiency. This capacitor has to supply the relatively high peak current to the coil and smooth the current ripple on the input supply. A minimum value of 4.7 $\mu$ F is acceptable if the input source is close to the device, but higher values will improve performance at lower input voltages, when the source impedance is high. The input capacitor should be mounted as close as possible to the IC

For maximum stability over temperature, capacitors with X7R dielectric are recommended, as these have a much smaller temperature coefficient than other types.

A table of recommended manufacturers is provided below:

Manufacturer	Website
Murata	<a href="http://www.murata.com">www.murata.com</a>
Taiyo Yuden	<a href="http://www.t-yuden.com">www.t-yuden.com</a>
Kemet	<a href="http://www.kement.com">www.kement.com</a>
AVX	<a href="http://www.avxcorp.com">www.avxcorp.com</a>

#### Inductor selection

The choice of inductor will depend on available board space as well as required performance. Small value inductors have the advantage of smaller physical size and may offer lower series resistance and higher saturation current compared to larger values. A disadvantage of lower inductor values is that they result in higher frequency switching, which in turn causes reduced efficiency due to switch losses. Higher inductor values can provide better performance at lower supply voltages. However, if the inductance is too high, the output power will be limited by the internal oscillator, which will prevent the coil current from reaching its peak value. This condition will arise whenever the ramp time ( $I_{LX(peak)} \times L/V_{IN}$ ) exceeds the nominal 5 $\mu$ s maximum 'on' time limit for the LX output.

Recommended inductor values for the ZXLD1601 are in the range 6.8 $\mu$ H to 22 $\mu$ H. The inductor should be mounted as close to the device as possible with low resistance connections to the LX and VIN pins.

Suitable coils for use with the ZXLD1601 are shown in the table below:

Part No.	L ( $\mu$ H)	DCR ( $\Omega$ )	I <sub>SAT</sub> (A)	Manufacturer
CMD4D11-100MC	10	0.457	0.5	Sumida <a href="http://www.sumida.com">www.sumida.com</a>
DO1608-103	10	0.16	1.1	Coilcraft <a href="http://www.coilcraft.com">www.coilcraft.com</a>
LQH31CN100	10	1.3	0.23	Murata <a href="http://www.murata.com">www.murata.com</a>
LB2012Y100MR	10	0.5	0.1	Taiyo Yuden <a href="http://www.t-yuden.com">www.t-yuden.com</a>

# OBSOLETE

## Closest Alternative is AP5727FDCG-7

### ZXLD1601

#### Diode selection

The rectifier diode (D1) should be a fast low capacitance Schottky diode with low reverse leakage at the working voltage. It should also have a peak current rating above the peak coil current and a continuous current rating higher than the maximum output load current.

The table below gives some typical characteristics for diodes that can be used with the ZXLD1601:

Diode	$V_F$ @ 100mA (mV)	$I_{FSM}$ (mA)	$I_C$ (mA)	$I_R$ at 30V ( $\mu$ A)	Package
ZHCS400	300	1000	400	15	SOD323
ZHCS500	300	1000	500	15	SOT23

#### Layout considerations

PCB tracks should be kept as short as possible to minimize ground bounce, and the ground pin of the device should be soldered directly to the ground plane. It is particularly important to mount the coil and the input/output capacitors close to the device to minimize parasitic resistance and inductance, which will degrade efficiency. The FB pin is a high impedance input, so PCB track lengths to this should also be kept as short as possible to reduce noise pickup. Excess capacitance from the FB pin to ground should be avoided.

**OBSOLETE**  
**Closest Alternative is AP5727FDCG-7**

**ZXLD1601**

**NOTES:**

# OBSOLETE

## Closest Alternative is AP5727FDCG-7

### ZXLD1601

#### PACKAGE OUTLINE

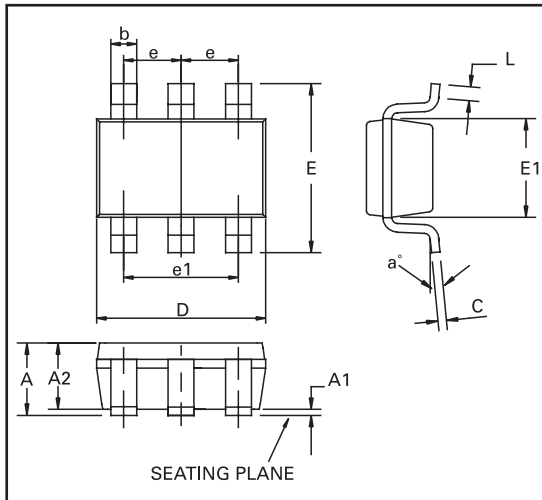

#### PACKAGE DIMENSIONS

DIM	Millimeters		Inches	
	Min	Max	Min	Max
A	0.80	1.10	0.0315	0.0433
A1	-	0.10	-	0.0039
A2	0.80	1.00	0.0315	0.0394
b	0.15	0.30	0.006	0.0118
C	0.08	0.25	0.0031	0.0098
D	2.00 BSC		0.0787 BSC	
E	2.10 BSC		0.0826 BSC	
E1	1.25	1.35	0.0492	0.0531
e	0.65 BSC		0.0255 BSC	
e1	1.30 BSC		0.0511 BSC	
L	0.26	0.46	0.0102	0.0181
a°	0°	8°	0°	8°

#### ORDERING INFORMATION

DEVICE	DEVICE DESCRIPTION	TEMPERATURE RANGE	PART MARK	TAPING OPTIONS
ZXLD1601H6	Boost converter in SC70-6	-40°C to +85°C	601	TA, TC

TA reels 3000 devices, TC reels 10000 devices

© Zetex Semiconductors plc 2004

Europe	Americas	Asia Pacific	Corporate Headquarters
Zetex GmbH Streitfeldstraße 19 D-81673 München Germany	Zetex Inc 700 Veterans Memorial Hwy Hauppauge, NY 11788 USA	Zetex (Asia) Ltd 3701-04 Metroplaza Tower 1 Hing Fong Road, Kwai Fong Hong Kong	Zetex Semiconductors plc Lansdowne Road, Chadderton Oldham, OL9 9TY United Kingdom
Telefon: (49) 89 45 49 49 0 Fax: (49) 89 45 49 49 49 <a href="mailto:europa.sales@zetex.com">europa.sales@zetex.com</a>	Telephone: (1) 631 360 2222 Fax: (1) 631 360 8222 <a href="mailto:usa.sales@zetex.com">usa.sales@zetex.com</a>	Telephone: (852) 26100 611 Fax: (852) 24250 494 <a href="mailto:asia.sales@zetex.com">asia.sales@zetex.com</a>	Telephone (44) 161 622 4444 Fax: (44) 161 622 4446 <a href="mailto:hq@zetex.com">hq@zetex.com</a>

These offices are supported by agents and distributors in major countries world-wide.

This publication is issued to provide outline information only which (unless agreed by the Company in writing) may not be used, applied or reproduced for any purpose or form part of any order or contract or be regarded as a representation relating to the products or services concerned. The Company reserves the right to alter without notice the specification, design, price or conditions of supply of any product or service.

For the latest product information, log on to [www.zetex.com](http://www.zetex.com).



ISSUE 3 - AUGUST 2004