

**COST EFFECTIVE GREEN PWM CONTROLLER****AP3105/V/L/R****General Description**

The AP3105/V/L/R is a low startup current, current mode PWM controller with green-mode power-saving operation. The PWM switching frequency at normal operation is set with 65kHz typically and the dithering of frequency will also improve the EMI feature. When the load decreases, the frequency will reduce and when at a very low load, the IC will enter the ‘burst mode’ to minimize switching loss.

About 20kHz frequency switching is to avoid the audible noise as well as reducing the standby loss. The skip mode point can be adjusted through the external resistor connected to the current sense resistor.

The AP3105/V/L/R features a lot of functions such as the Leading-Edge Blanking (LEB) of the current sensing, internal slope compensation and several protection functions including cycle-by-cycle current limit (OCP), VCC Over Voltage Protection (VOVP), OTP and OLP protection. The versatile latch function can be set by the customer through few components.

This IC is available in SOT-23-6 package.

Features

- Very Low Start-up Current
- Current Mode Control
- Non-audible-noise Green-mode Control
- Skip Mode Adjustable
- Internal Slope Compensation
- Soft Start During Startup Process
- Frequency Fold Back for High Average Efficiency
- Secondary Short Winding Protection with FOCP
- Soft Switching for Reducing EMI
- VCC Maintain Mode
- Latch Function for OTP/OVP
- Useful Pin Fault Protection:
 - SENSE Pin Floating
 - CTRL Pin Short to Ground
 - FB/Opto-coupler Open/Short
- Comprehensive System Protection Feature:
 - VCC Over Voltage Protection (VOVP)
 - Over Load Protection (OLP)
- Mini Size with Packages
- Pin to Pin Compatible with AP3103

Applications

- Switching AC-DC Adapter/Charger
- ATX/BTX Auxiliary Power
- Set-top Box(STB) Power Supply
- Open Frame Switching Power Supply

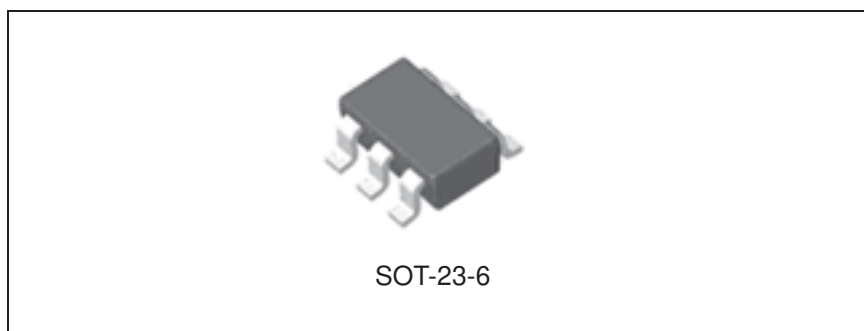

Figure 1. Package Type of AP3105/V/L/R

COST EFFECTIVE GREEN PWM CONTROLLER

AP3105/V/L/R

Pin Configuration

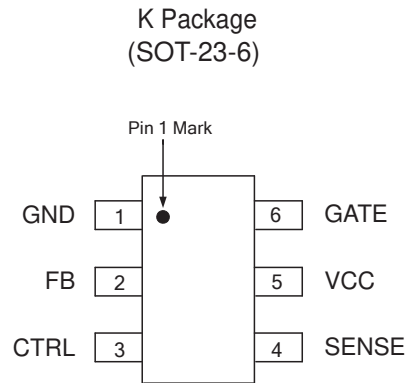

Figure 2. Pin Configuration of AP3105/V/L/R (Top View)

Pin Description

Pin Number	Pin Name	Function
1	GND	Signal ground. Current return for driver and control circuits
2	FB	Feedback. Directly connected to the opto-coupler
3	CTRL	Latch trigger if this pin voltage drops below a threshold or over another threshold, leave CTRL pin open if this function is not needed. Connecting a NTC thermistor to GND can achieve OTP protection
4	SENSE	Current Sense
5	VCC	Supply voltage of driver and control circuits
6	GATE	Gate driver output



COST EFFECTIVE GREEN PWM CONTROLLER

AP3105/V/L/R

Ordering Information

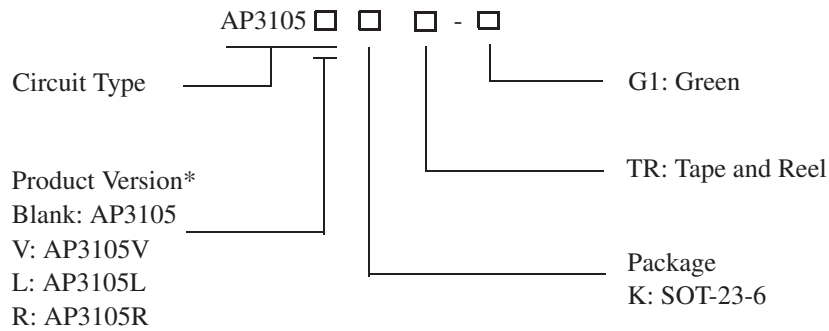

Package	Part Number	Marking ID	Packing Type
SOT-23-6	AP3105KTR-G1	GHN	Tape & Reel
	AP3105VKTR-G1	GHO	Tape & Reel
	AP3105LKTR-G1	GHP	Tape & Reel
	AP3105RKTR-G1	GHQ	Tape & Reel

BCD Semiconductor's products, as designated with "G1" suffix in the part number, are RoHS compliant and Green.

*** Product Version Classification (with Different Protection Functions)**

Product Version	Frequency	VOVP	OLP& SOCP	CTRL (Low)	CTRL (High)
AP3105	65kHz	Auto-Recoverable	Auto-Recoverable	Latch	Auto-Recoverable
AP3105V	65kHz	Latch	Auto-Recoverable	Latch	Latch
AP3105L	65kHz	Latch	Latch	Latch	Latch
AP3105R	65kHz	Auto-Recoverable	Auto-Recoverable	Auto-Recoverable	Latch

**COST EFFECTIVE GREEN PWM CONTROLLER****AP3105/V/L/R****Absolute Maximum Ratings (Note 1)**

Parameter	Symbol	Value	Unit
Power Supply Voltage	V_{CC}	30	V
Gate Output Current	I_O	350	mA
Input Voltage to FB, SENSE, CTRL	$V_{FB}, V_{SENSE}, V_{CTRL}$	-0.3 to 7	V
Thermal Resistance (Junction to Ambient)	θ_{JA}	250	°C/W
Power Dissipation at $T_A < 25^\circ\text{C}$	P_D	500	mW
Operating Junction Temperature	T_J	-40 to 150	°C
Storage Temperature Range	T_{STG}	150	°C
ESD (Human Body Model)		3000	V
ESD (Machine Model)		300	V

Note 1: Stresses greater than those listed under "Absolute Maximum Ratings" may cause permanent damage to the device. These are stress ratings only, and functional operation of the device at these or any other conditions beyond those indicated under "Recommended Operating Conditions" is not implied. Exposure to "Absolute Maximum Ratings" for extended periods may affect device reliability.

Recommended Operating Conditions

Parameter	Symbol	Min	Max	Unit
Supply Voltage	V_{CC}	10	25	V



COST EFFECTIVE GREEN PWM CONTROLLER

AP3105/V/L/R

Electrical Characteristics

V_{CC}=16V, T_A=25°C, unless otherwise specified.

Parameter	Symbol	Conditions	Min	Typ	Max	Unit
Supply Voltage (VCC Pin)						
Startup Current	I _{STARTUP}		2	5	25	μA
Operating Supply Current	I _{CC}	V _{FB} =0V, C _L =1nF	0.5	0.85	1.2	mA
		V _{FB} =3V, C _L =0nF	0.6	1.2	2.0	
UVLO (on)			14.5	15.5	16.5	V
VCC Maintain			9.7	10.2	10.7	V
UVLO (off)			7.6	8.6	9.6	V
VCC OVP			27	28.5	30	V
VCC Clamp		I _{CC} =5mA	31	34		V
PWM Section/Oscillator Section						
Maximum Duty Cycle			70	75	80	%
Oscillation Frequency			60	65	70	kHz
Green Mode Frequency			20		30	kHz
Frequency Temperature Stability		-20°C to 125°C (Note 2)			5	%
Frequency Voltage Stability		V _{CC} =12V to 30V			3	%
Frequency Dithering			±4	±6	±8	%
Current Sense Section (SENSE Pin)						
Maximum SENSE Voltage	V _{CS}	V _{FB} =3.6V	0.800	0.850	0.900	V
FOCP Voltage			1.65	1.8	1.95	V
LEB Time of SENSE			150	250	350	ns
Delay to Output (Note 2)				100		ns
Soft-start Time			3	5	8	ms
Feedback Input Section (FB Pin)						
The Ratio of Input Voltage to Current Sense Voltage			2.5	3	3.5	V/V
Input Impedance			7	10	13	kΩ
Source Current		V _{FB} =0V	-0.75	-0.5	-0.25	mA
Green Mode Threshold				2		V
Input Voltage for Zero Duty			1.3	1.55	1.8	V

**COST EFFECTIVE GREEN PWM CONTROLLER****AP3105/V/L/R****Electrical Characteristics** $V_{CC}=16V$, $T_A=25^{\circ}C$, unless otherwise specified.

Parameter	Symbol	Conditions	Min	Typ	Max	Unit
Output Section (GATE Pin)						
Output Low Level		$I_O=20mA$, $V_{CC}=12V$			1	V
Output High Level		$I_O=20mA$, $V_{CC}=12V$	8			V
Output Clamping			11	13	15	V
Rising Time (Note 2)		$C_L=1nF$, $V_{CC}=13V$		150	250	ns
Falling Time (Note 2)		$C_L=1nF$, $V_{CC}=13V$		50	100	ns
Protection Section (CTRL Pin)						
Source Current			90	100	110	μA
Internal Reference Voltage				1.5		V
Low Threshold Trigger for Latch			0.47	0.5	0.53	V
High Threshold Trigger for Latch			2.35	2.5	2.65	V
Pull-up Current (Note 3)					2	mA
Delay Time Section						
Delay of Short Circuit Protection			22	32	40	ms
Delay of Hiccup Protection		VCC OVP		25		μs

Note 2. Guaranteed by design.

Note 3. The sourcing current of CTRL pin must be limited below 5mA. Otherwise it may cause permanent damage to the device.



Typical Performance Characteristics

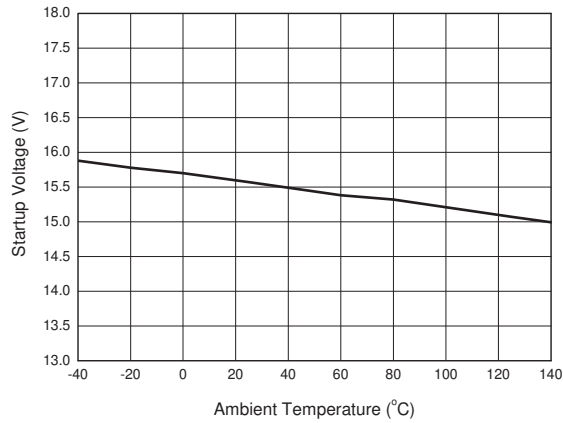

Figure 4. Startup Voltage vs. Ambient Temperature

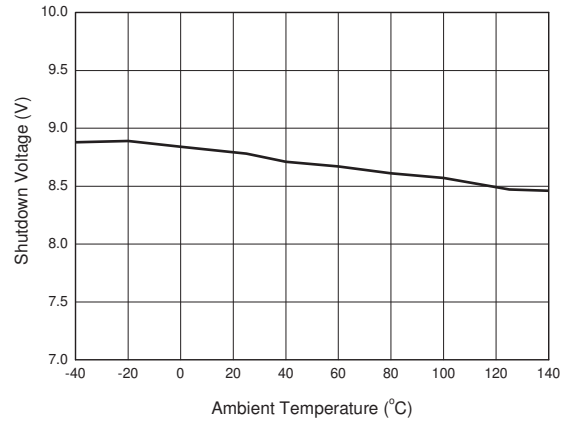

Figure 5. Shutdown Voltage vs. Ambient Temperature

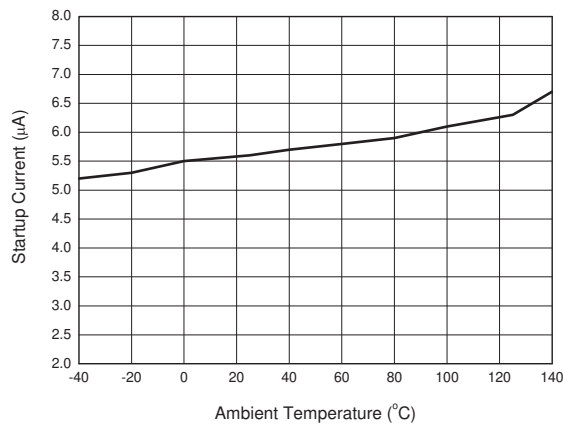

Figure 6. Startup Current vs. Ambient Temperature

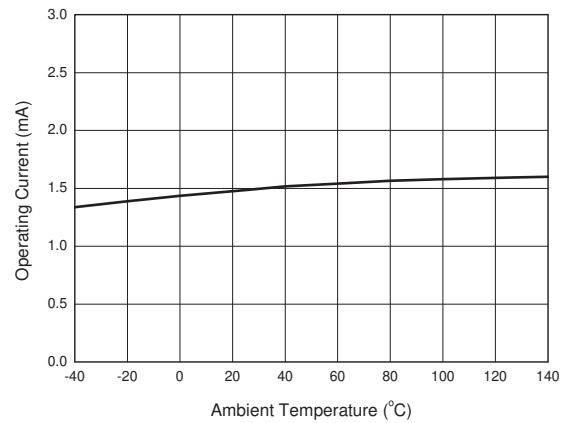
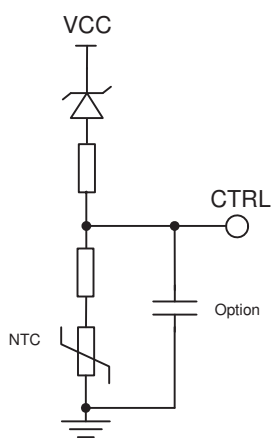
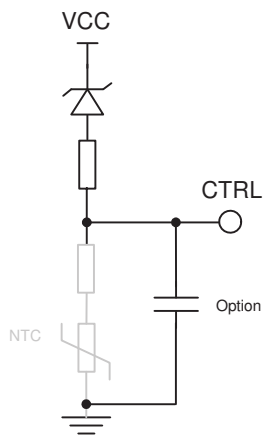

Figure 7. Operating Current vs. Ambient Temperature

CTRL Utilization for Latch



OVP and OTP



OVP

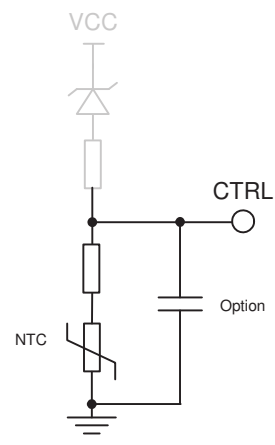

OTP

COST EFFECTIVE GREEN PWM CONTROLLER

AP3105/V/L/R

Operation Description

The AP3105/V/L/R is specifically designed for off-line AC-DC power supply used in LCD monitor, notebook adapter and battery charger applications. It offers a cost effective solution with a versatile protection function.

Start-up Current and UVLO

The start-up current of AP3105/V/L/R is optimized to realize ultra low current (5μA typical) so that VCC capacitor can be charged more quickly. The direct benefit of low start-up current is the availability of using large start-up resistor, which minimizes the resistor power loss for high voltage AC input.

An UVLO comparator is included in AP3105/V/L/R to detect the voltage on VCC pin. It ensures that AP3105/V/L/R can draw adequate energy from hold-up capacitor during power-on. The turn-on threshold is 15.5V and the turn-off threshold is 8.6V.

Current Sense Comparator and PWM Latch

The AP3105/V/L/R operates as a current mode controller, the output switch conduction is initiated by every oscillator cycle and is terminated when the peak inductor current reaches the threshold level established by the FB pin. The inductor current signal is converted to a voltage signal by inserting a reference sense resistor R_S . The inductor current under normal operating conditions is controlled by the voltage at FB pin. The relation between peak inductor current (I_{PK}) and V_{FB} is:

$$I_{PK} = (V_{FB} - 0.8) / 3R_S$$

Moreover, FOCV with 1.8V threshold is only about 100ns delay, which can avoid some catastrophic damages such as secondary rectifier short test. Few drive cycles can alleviate the destruction range and get better protection.

Leading-edge Blanking

A narrow spike on the leading edge of the current waveform can usually be observed when the power MOSFET is turned on. A 250ns leading-edge blank is built-in to prevent the false-triggering caused by the turn-on spike. During this period, the current limit

comparator is disabled and the gate driver can not be switched off.

At the time of turning on the MOSFET, a negative undershoot (maybe larger than -0.3V) can occur on the SENSE pin. So it is strongly recommended to add a small RC filter or at least connect a resistor “R” on this pin to protect the IC (Shown as Figure 8).

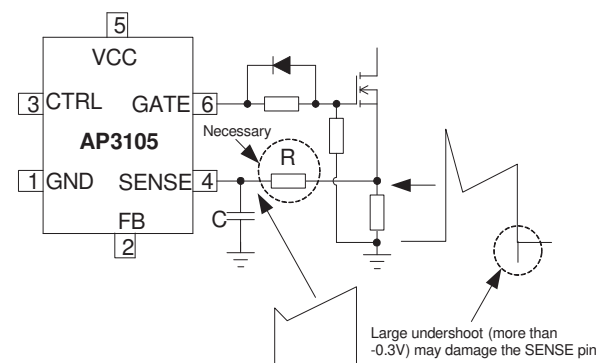

Figure 8

Built-in Slope Compensation

It is well known that a continuous current mode SMPS may become unstable when the duty cycle exceeds 50%. The built-in slope compensation can improve the stability, so there is no need for design engineer to spend much time on that.

FB Pin and Short Circuit Protection

This pin is normally connected to the opto-coupler and always paralleled with a capacitor for loop compensation. When the voltage at this pin is greater than 4.2V and lasts for about 32ms, the IC will enter the protection mode. For AP3105/V/R, the system will enter hiccup mode to wait the V_{CC} decreasing to low UVLO level, then the IC will try to restart until the failure removed. And when this voltage is less than 1.55V, the IC will stop the drive pulse immediately. Therefore, this feature can be used for short circuit protection, which makes the system immune from damage. Normally, output short makes the V_{FB} value to the maximum because the opto-coupler is cut off.

V_{CC} Maintain Mode

During light load or step load, V_{FB} will drop and be

COST EFFECTIVE GREEN PWM CONTROLLER

AP3105V/L/R

Operation Description (Continued)

lower than 1.55V, thus the PWM drive signal will be stopped, and there is no more new energy transferred due to no switching. Therefore, the IC supply voltage may reduce to the shutdown threshold voltage and system may enter the unexpected restart mode. To avoid this, the AP3105V/L/R hold a so-called V_{CC} maintain mode which can supply energy to V_{CC} .

When V_{CC} decreases to a setting threshold, the V_{CC} maintain comparator will output some drive signal to make the system switch and provide a proper energy to V_{CC} pin. The V_{CC} maintain function will cooperate the PWM and burst mode loop which can make the output voltage variation be within the regulation. This mode is very useful for reducing startup resistor loss and achieve a better standby performance with a low value V_{CC} capacitor. The V_{CC} is not easy to touch the shutdown threshold during the startup process and step load. This will also simplify the system design. The normal V_{CC} voltage is suggested to be designed a little higher than V_{CC} maintain threshold thus can achieve the best balance between the standby and step load performance.

System Protection and Pin Fault Protection

The AP3105V/L/R provides versatile system and pin fault protections. The OCP comparator realizes the cycle-by-cycle current limiting (OCP). In universal input line voltage, the IC realizes the constant over load protection (OLP). V_{CC} over voltage protection can be applied as the primary OVP or opto-coupler broken protection. The AP3105V/L/R also has pin fault connection protection including floating and short connection. The floating pin protection include the SENSE, FB, etc.. The short pin protection includes the CTRL pin short protection. When these pins are floated or CTRL pin is shorted to ground, PWM switching will be disabled, thus protecting the power system.

Latch Protection Function

For some applications, the system requires the latch protection function. The CTRL pin has two kinds of modes to trigger the latch protection: high level trigger and low level trigger. The low threshold is 0.5V and high threshold voltage is 2.5V. Some version will have only one mode. Once the latch protection is triggered, the IC will disable the output signal, and the bulk capacitor provides the energy to IC through the startup resistor to ensure the IC disable the output (latch mode). This mode will be not released until the AC input is shut off. So, the de-latch time is mainly depending on the HV startup bulk capacitor value. Therefore, if the system want a short de-latch time, it is better for the startup resistor take power from the point before the rectifier bridge as illustrated in below figure.

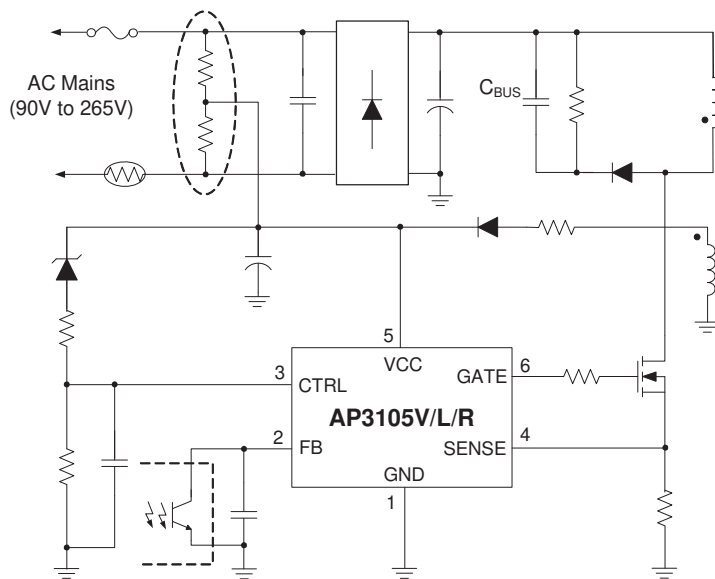



COST EFFECTIVE GREEN PWM CONTROLLER

AP3105/V/L/R

Mechanical Dimensions

SOT-23-6

Unit: mm(inch)

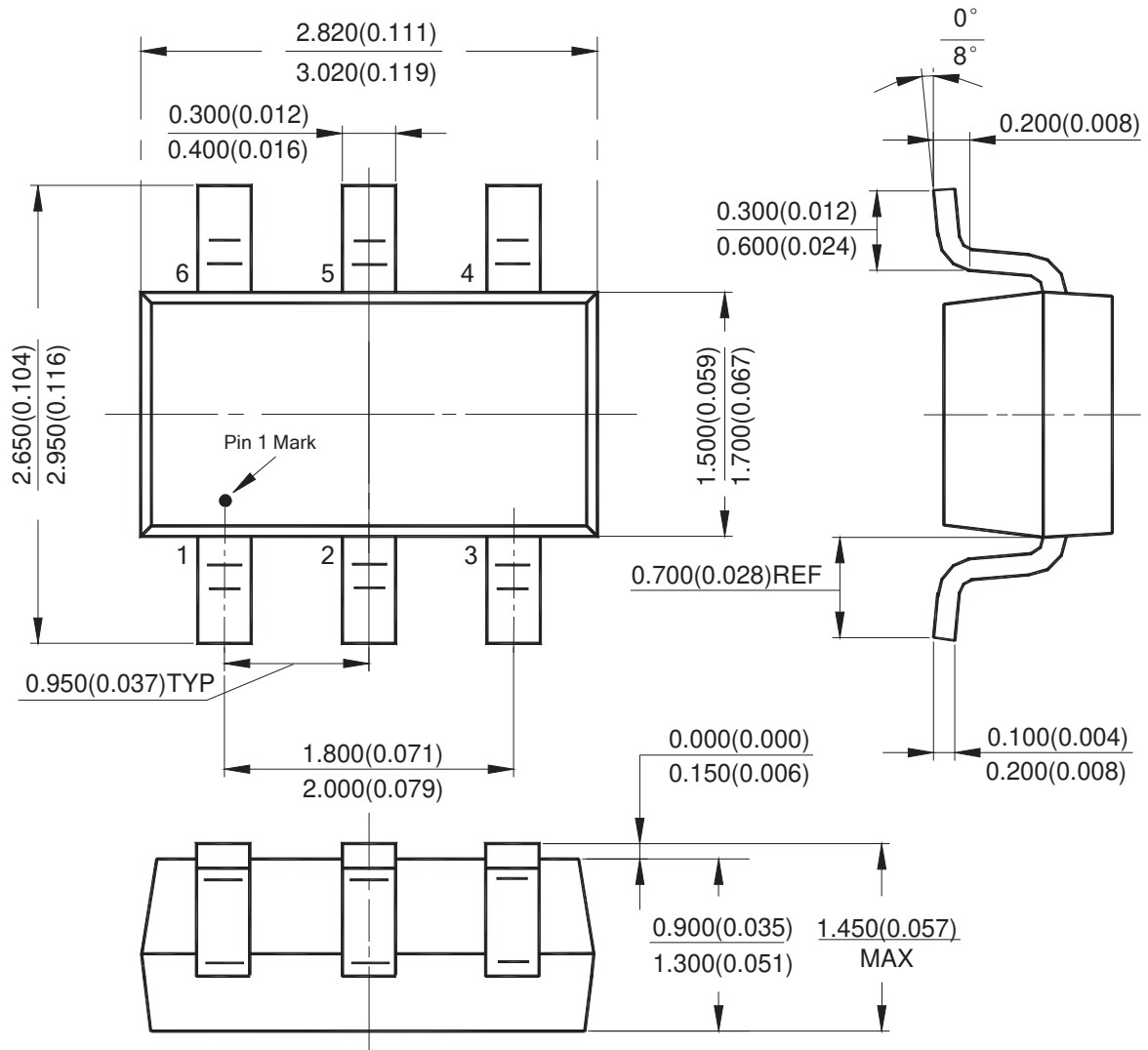



BCD Semiconductor Manufacturing Limited

<http://www.bcdsemi.com>

IMPORTANT NOTICE

BCD Semiconductor Manufacturing Limited reserves the right to make changes without further notice to any products or specifications herein. BCD Semiconductor Manufacturing Limited does not assume any responsibility for use of any its products for any particular purpose, nor does BCD Semiconductor Manufacturing Limited assume any liability arising out of the application or use of any its products or circuits. BCD Semiconductor Manufacturing Limited does not convey any license under its patent rights or other rights nor the rights of others.

MAIN SITE

- Headquarters

BCD Semiconductor Manufacturing Limited

No. 1600, Zi Xing Road, Shanghai Zizhu Science-based Industrial Park, 200241, China
Tel: +86-21-24162266, Fax: +86-21-24162277

- Wafer Fab

Shanghai SIM-BCD Semiconductor Manufacturing Co., Ltd.

800 Yi Shan Road, Shanghai 200233, China
Tel: +86-21-6485 1491, Fax: +86-21-5450 0008

REGIONAL SALES OFFICE

Shenzhen Office

Shanghai SIM-BCD Semiconductor Manufacturing Co., Ltd., Shenzhen Office

Unit A Room 1203, Skyworth Bldg., Gaoxin Ave.1.S., Nanshan District, Shenzhen, China
Tel: +86-755-8826 7951
Fax: +86-755-8826 7865

Taiwan Office

BCD Semiconductor (Taiwan) Company Limited

4F, 298-1, Rui Guang Road, Nei-Hu District, Taipei, Taiwan
Tel: +886-2-2656 2808
Fax: +886-2-2656 2806

USA Office

BCD Semiconductor Corp.

30920 Huntwood Ave. Hayward, CA 94544, USA
Tel : +1-510-324-2988
Fax: +1-510-324-2788