



IR Emitter and Detector Product Data Sheet

LTR-4206

Spec No.: DS-50-92-0072

Effective Date: 08/14/2002

Revision: D

LITE-ON DCC

RELEASE

BNS-OD-FC001/A4

LITEON LITE-ON TECHNOLOGY CORPORATION

Property of LITE-ON Only

FEATURES

- * WIDE RANGE OF COLLECTOR CURRENT
- * LENSED FOR HIGH SENSITIVITY
- * LOW COST PLASTIC PACKAGE

PACKAGE DIMENSIONS

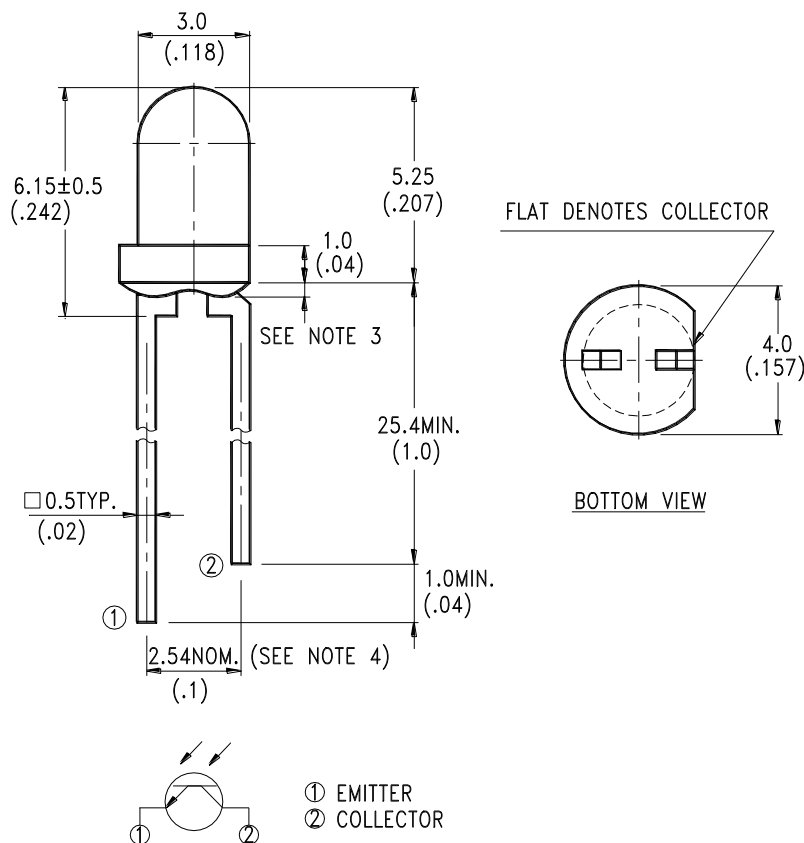

NOTES:

1. All dimensions are in millimeters (inches).
2. Tolerance is $\pm 0.25\text{mm}(.010\text{'})$ unless otherwise noted.
3. Protruded resin under flange is $1.5\text{mm}(.059\text{'})$ max.
4. Lead spacing is measured where the leads emerge from the package.
5. Specifications are subject to change without notice for performance improvement.

ABSOLUTE MAXIMUM RATINGS AT T_A=25°C

PARAMETER	MAXIMUM RATING	UNIT
Power Dissipation	100	mW
Collector-Emitter Voltage	30	V
Emitter-Collector Voltage	5	V
Operating Temperature Range	-40°C to + 85°C	
Storage Temperature Range	-55°C to + 100°C	
Lead Soldering Temperature [1.6mm(.063") From Body]	260°C for 5 Seconds	

ELECTRICAL / OPTICAL CHARACTERISTICS AT T_A=25°C

PARAMETER	SYMBOL	MIN.	TYP.	MAX.	UNIT	TEST CONDITION	BIN NO.
Collector-Emitter Breakdown Voltage	V _{(BR)CEO}	30			V	I _C = 1mA Ee = 0mW/cm ²	
Emitter-Collector Breakdown Voltage	V _{(BR)ECO}	5			V	I _E = 100 μA Ee = 0mW/cm ²	
Collector Emitter Saturation Voltage	V _{CE(SAT)}			0.4	V	I _C = 0.5mA Ee = 1mW/cm ²	
Rise Time	Tr		10		μs	V _{CC} = 5V I _C = 1mA R _L = 1KΩ	
Fall Time	Tf		10		μs		
Collector Dark Current	I _{CEO}			100	nA	V _{CE} = 10V Ee = 0mW/cm ²	
On State Collector Current	I _{C(ON)}	0.8		2.4	mA	V _{CE} = 5V Ee = 1mW/cm ² λ = 940nm	BIN C
		1.6		4.8			BIN D
		3.2		9.6			BIN E
		6.4					BIN F

TYPICAL ELECTRICAL / OPTICAL CHARACTERISTICS CURVES

(25°C Ambient Temperature Unless Otherwise Noted)

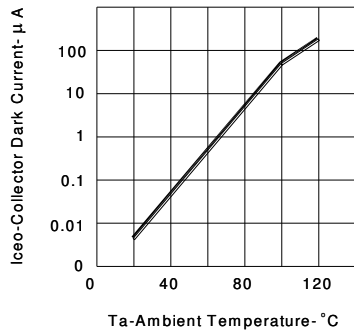

FIG.1 COLLECTOR DARK CURRENT VS AMBIENT TEMPERATURE

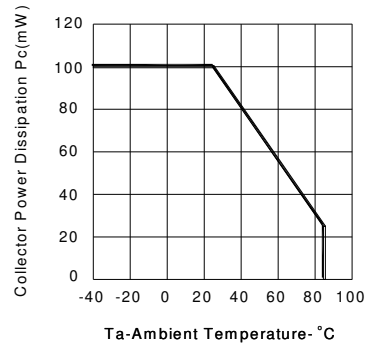

FIG.2 COLLECTOR POWER DISSIPATION VS AMBIENT TEMPERATURE

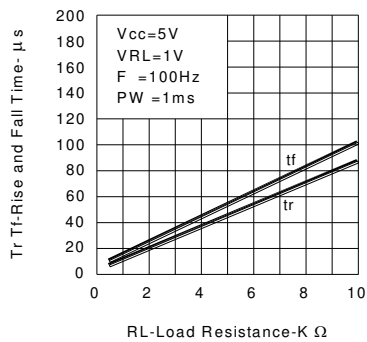

FIG.3 RISE AND FALL TIME VS LOAD RESISTANCE

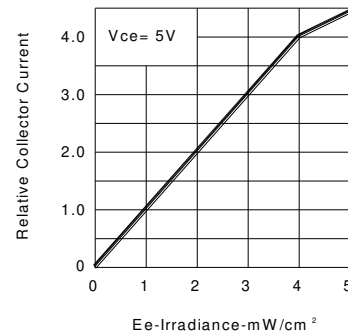

FIG.4 RELATIVE COLLECTOR CURRENT VS IRRADIANCE

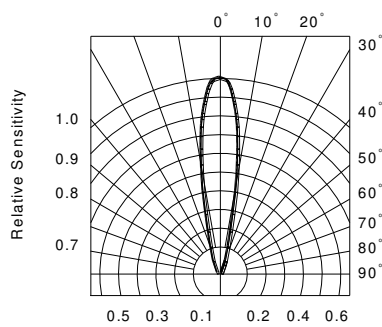

FIG.5 SENSITIVITY DIAGRAM