

ICB, M12 - Extra short body version



Proximity inductive sensors with extended range and nickel-plated brass housing



Benefits

- Sensing distance: 4 to 8 mm
- Flush or non-flush types
- Extra short body versions
- Rated operational voltage (U_b): 10 - 36 VDC
- Output: DC 200 mA, NPN or PNP
- Normally open or Normally closed
- LED indication for output ON
- Protection: reverse polarity, short circuit, transients
- Cable or M12 plug versions
- According to IEC 60947-5-2
- Laser engraved on front cap, permanently legible
- Extended temperature range of -25°C to $+70^{\circ}\text{C}$

Description

A family of inductive proximity switches in industrial standard nickel-plated brass housings. They are characterized by extremely high performance in a very small design, to satisfy the most demanding applications, also where the space available for the sensor is limited and extended sensing range is requested.

Output is open collector NPN or PNP transistors.

References

Order code

 **ICB12S23**

Enter the code option instead of

Code	Option	Description
ICB	-	Proximity inductive sensors, nickel-plated brass housing
12	-	Housing size
S	-	Housing length
23	-	Thread length
<input type="checkbox"/>	F	Detection principle: flush mounting
	N	Detection principle: non-flush mounting
<input type="checkbox"/>	04	Sensing distance: 4mm
	08	Sensing distance: 8mm
<input type="checkbox"/>	M1	M12 plug
	A2	2 m PVC cable
<input type="checkbox"/>	N	Output type: NPN
	P	Output type: PNP
<input type="checkbox"/>	O	Output configuration: normally open
	C	Output configuration: normally closed

Selection guide

Con- nec- tion	Rated operating distance Sn	Ordering no. NPN, Normally open	Ordering no. PNP, Normally open	Ordering no. NPN, Normally closed	Ordering no. PNP, Normally closed
Cable	4 mm ¹⁾	ICB12S23F04A2NO	ICB12S23F04A2PO	ICB12S23F04A2NC	ICB12S23F04A2PC
Cable	8 mm ²⁾	ICB12S23N08A2NO	ICB12S23N08A2PO	ICB12S23N08A2NC	ICB12S23N08A2PC
Plug	4 mm ¹⁾	ICB12S23F04M1NO	ICB12S23F04M1PO	ICB12S23F04M1NC	ICB12S23F04M1PC
Plug	8 mm ²⁾	ICB12S23N08M1NO	ICB12S23N08M1PO	ICB12S23N08M1NC	ICB12S23N08M1PC

¹⁾ For flush mounting in metal

²⁾ For non-flush mounting in metal

Structure

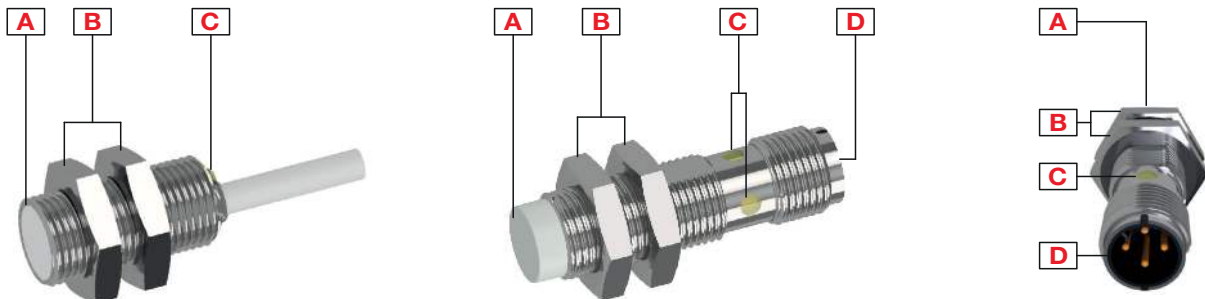

Element	Component	Function
A	Sensing face	Flush or non-flush
B	2 nuts	For sensor mounting
C	LED	Yellow LED: Output flashing: short circuit or overload indication
D	M12 x 1, 4 pin, male connector	For plug versions only

Sensing

Detection

Assured operating sensing distance (S_a)	$0 \leq S_a \leq 0.81 \times S_n$
Effective operating distance (S_r)	$0.9 \times S_n \leq S_r \leq 1.1 \times S_n$
Usable operating distance (S_u)	$0.9 \times S_r \leq S_u \leq 1.1 \times S_r$
Differential travel (H) (Hysteresis)	1 to 20% of sensing dist.

Correction factors

The specific operating distance S_n refers to defined measuring conditions. The following data have to be considered as general guidelines.

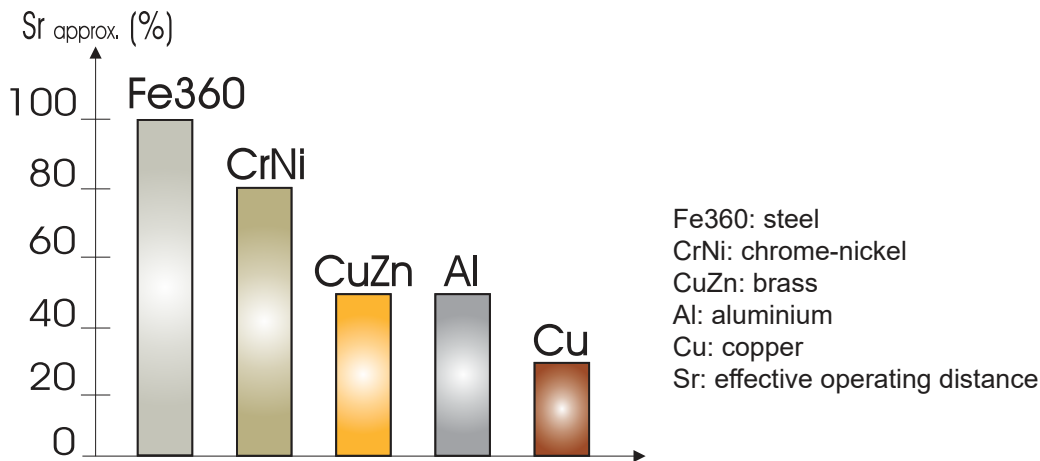

Fig. 1 The rated operating distance is reduced by the use of metals and alloys other than Fe360. The most important reduction factors for inductive proximity sensors are shown in the figure.

Accuracy

Repeat accuracy (R)	$\leq 10\%$
---------------------	-------------

Features

Power Supply

Rated operational voltage (U_b)	10 to 36 VDC (ripple incl.)
Ripple (U_{rpp})	$\leq 10\%$
No load supply current (I_o)	≤ 16 mA
Power ON delay (t_v)	≤ 40 ms

Outputs

Output current (I_o)	≤ 200 mA
OFF-state current (I_o)	≤ 50 μ A
Voltage drop (U_d)	Max. 2.5 VDC @ 200 mA
Protection	Reverse polarity, short-circuit, transients
Voltage transient	1 kV/0.5 J

Response times

Max. operating frequency (f)	≤ 2000 Hz
------------------------------	----------------



Indication

Indication for output ON NO version NC version	Activated LED, yellow Target present Target not present
Indication for short circuit/ overload	LED blinking (f = 2 Hz)

Environmental

Ambient temperature Operating Storage	-25° to +70°C (-13° to +158°F) -25° to +80°C (-13° to +176°F)
Shock and vibration	IEC 60947-5-2/7.4
Degree of protection	IP67

Compatibility and conformity

EMC protection - According to IEC 60947-5-2	
Electrostatic discharge (ESD)	IEC 61000-4-2 8 kV air discharge, 4 kV contact discharge
Radiated radio frequency	IEC 61000-4-3 3 V/m
Burst immunity	IEC 61000-4-4 2 kV
Conducted radio frequency	IEC 61000-4-6 3 V
Power frequency magnetic fields	IEC 61000-4-8 30 A/m
MTTF _d	3090 years @ 50°C (122°F)
Approvals	 
	CCC is not required for products rated ≤ 36 V

Mechanical data

Weight (cable/nuts included)	Max. 68 g
Mounting	Flush or non flush mountable
Material	Body: nickel-plated brass Front: grey thermoplastic polyester
Tightening torque	10 Nm

Electrical connection

Cable	Ø 4.1 x 2 m, 3 x 0.25 mm ² , grey PVC, oil proof
Plug	M12 x 1

Connection Diagrams

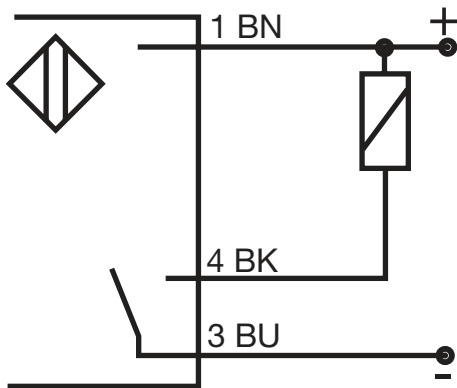

Fig. 2 NPN - Normally open

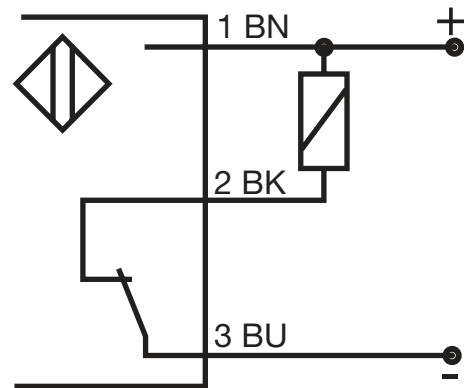

Fig. 3 NPN - Normally closed

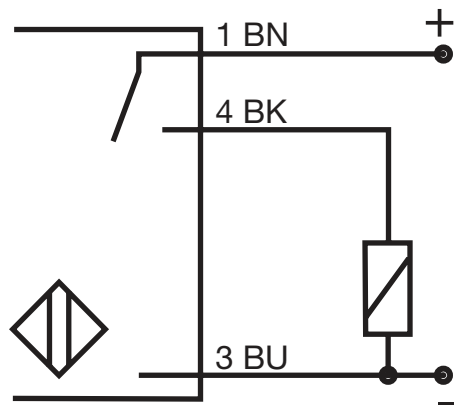

Fig. 4 PNP - Normally open

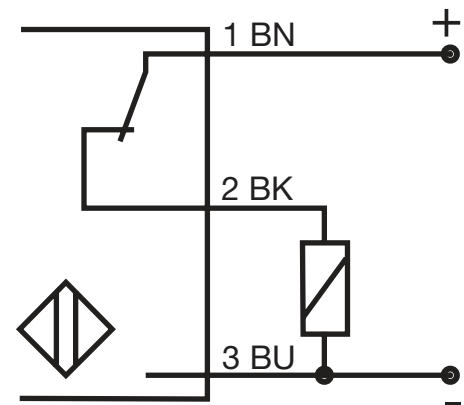

Fig. 5 PNP - Normally closed

Colour code		
BN: brown	BK: black	BU: blue

Dimensions

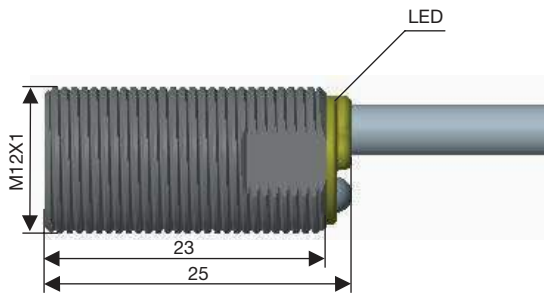

Fig. 6 Short body, flush version, cable

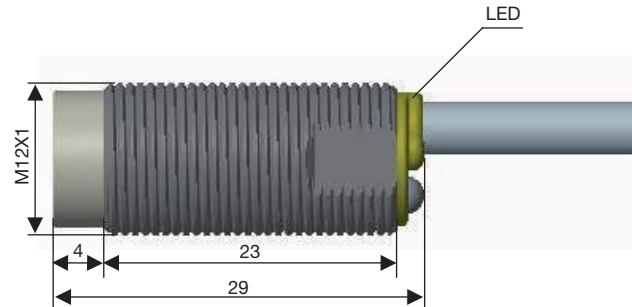

Fig. 7 Short body, non-flush version, cable

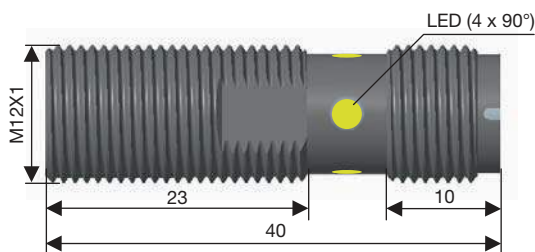

Fig. 8 Short body, flush version, plug

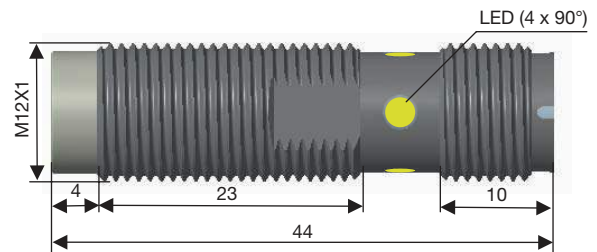
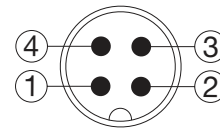
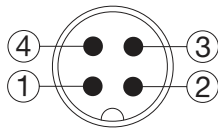

Fig. 9 Short body, non-flush version, plug



Installation

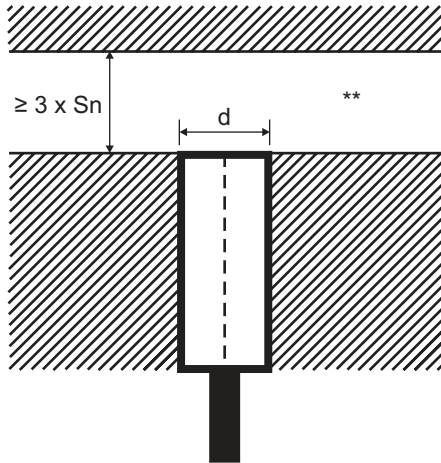

Fig. 10 Flush sensor, when installed in damping material

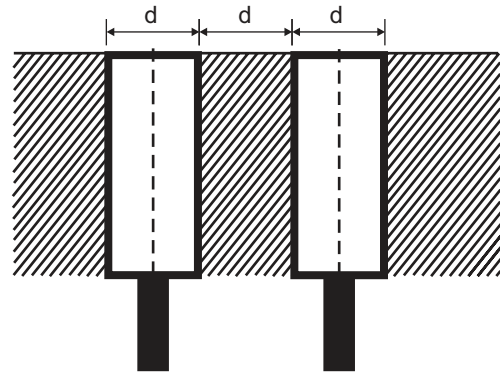

Fig. 11 Flush sensors, when installed together in damping material

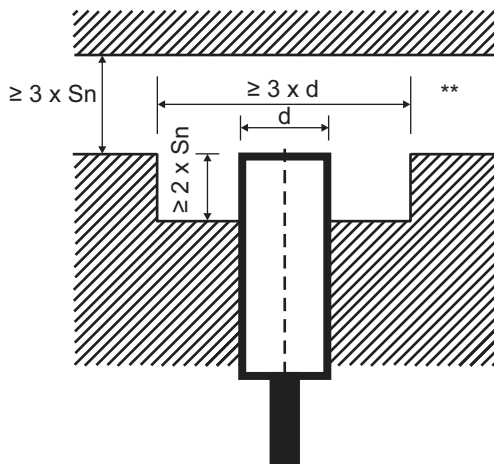

Fig. 12 Non-flush sensor, when installed in damping material

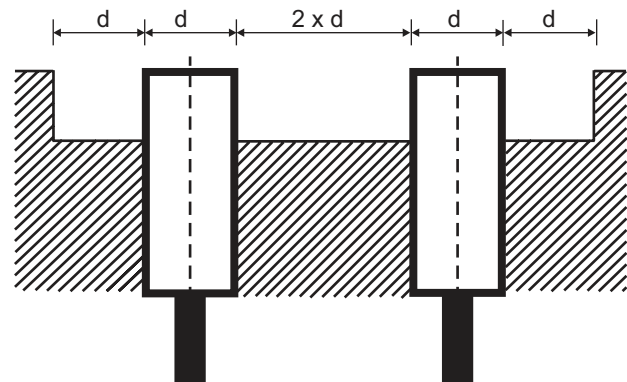

Fig. 13 Non-flush sensors, when installed together in damping material

** Free zone or non-damping material

S_n : nominal sensing distance
 d: sensor diameter: 12 mm

 Sensors installed opposite each other

Fig. 14 For sensors installed opposite each other, a minimum space of $6 \times S_n$ (the nominal sensing distance) must be observed

Delivery contents

- Inductive proximity switch
- 2 nuts
- Packaging: plastic bag

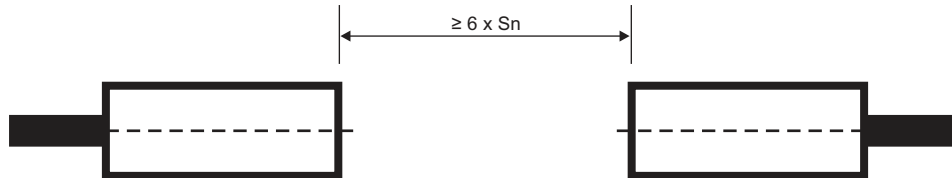

COPYRIGHT ©2019
Content subject to change. Download the PDF: www.productselection.net