

REVISIONS					
P	LTR	DESCRIPTION	DATE	DMN	APVD
H2		REVISED PER ECR-18-005392	27NOV2018	BDA	SG

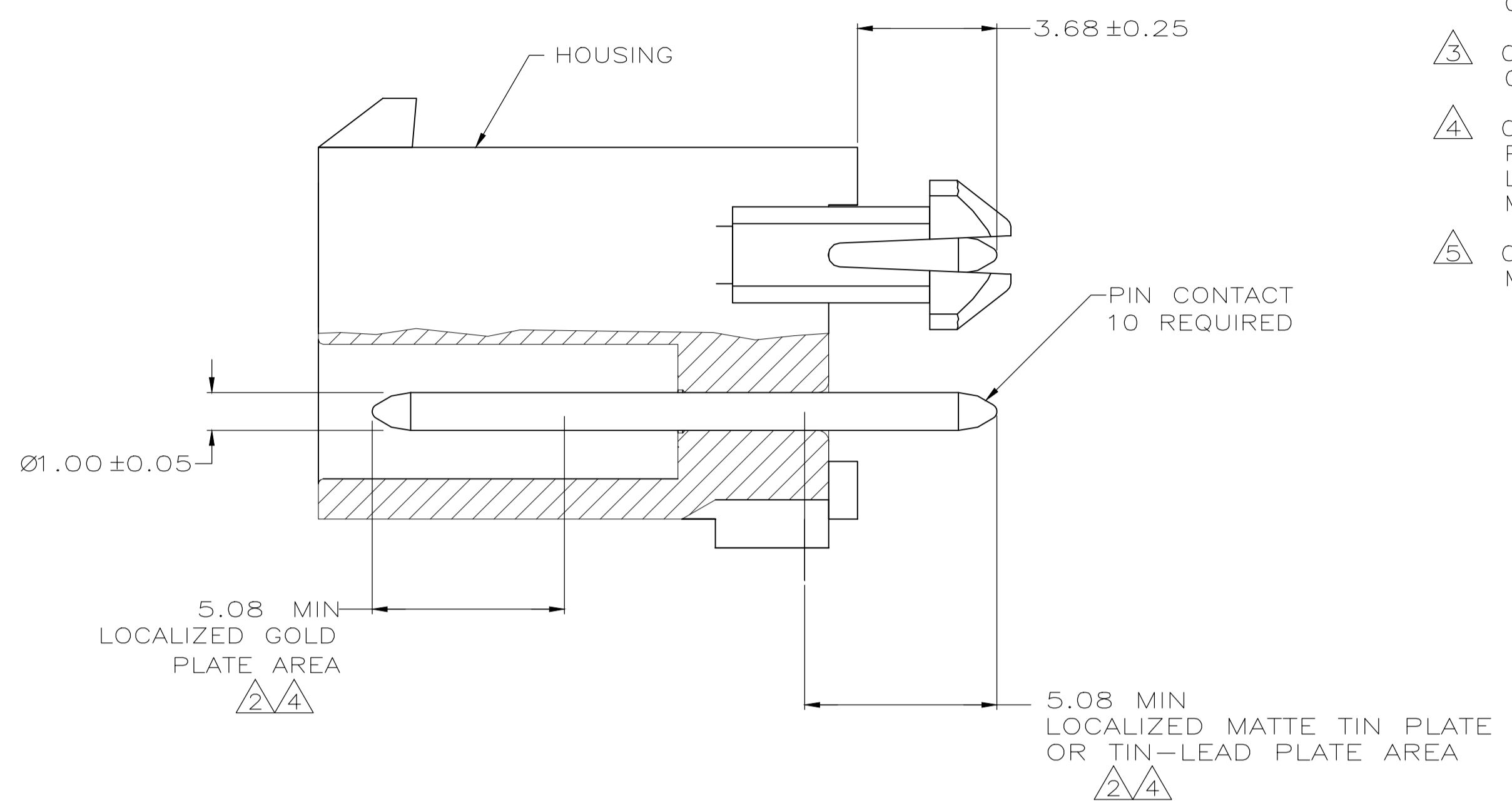

- PINS TO COMPLY WITH AMP SOLDERABILITY SPEC 109-11-3.
- 0.00076 MIN GOLD PLATE IN THE LOCALIZED PLATE AREA, 0.00381 MATTE TIN LEAD IN THE LOCALIZED PLATE AREA, BOTH OVER 0.00127 MIN NICKEL.
- 0.00381 MIN MATTE TIN LEAD PLATE OVER 0.00127 MIN NICKEL.
- 0.00076 MIN GOLD PLATE IN THE LOCALIZED PLATE AREA, 0.00381 MATTE TIN IN THE LOCALIZED PLATE AREA, BOTH OVER 0.00127 MIN NICKEL.
- 0.00381 MIN MATTE TIN PLATE OVER 0.00127 MIN NICKEL.

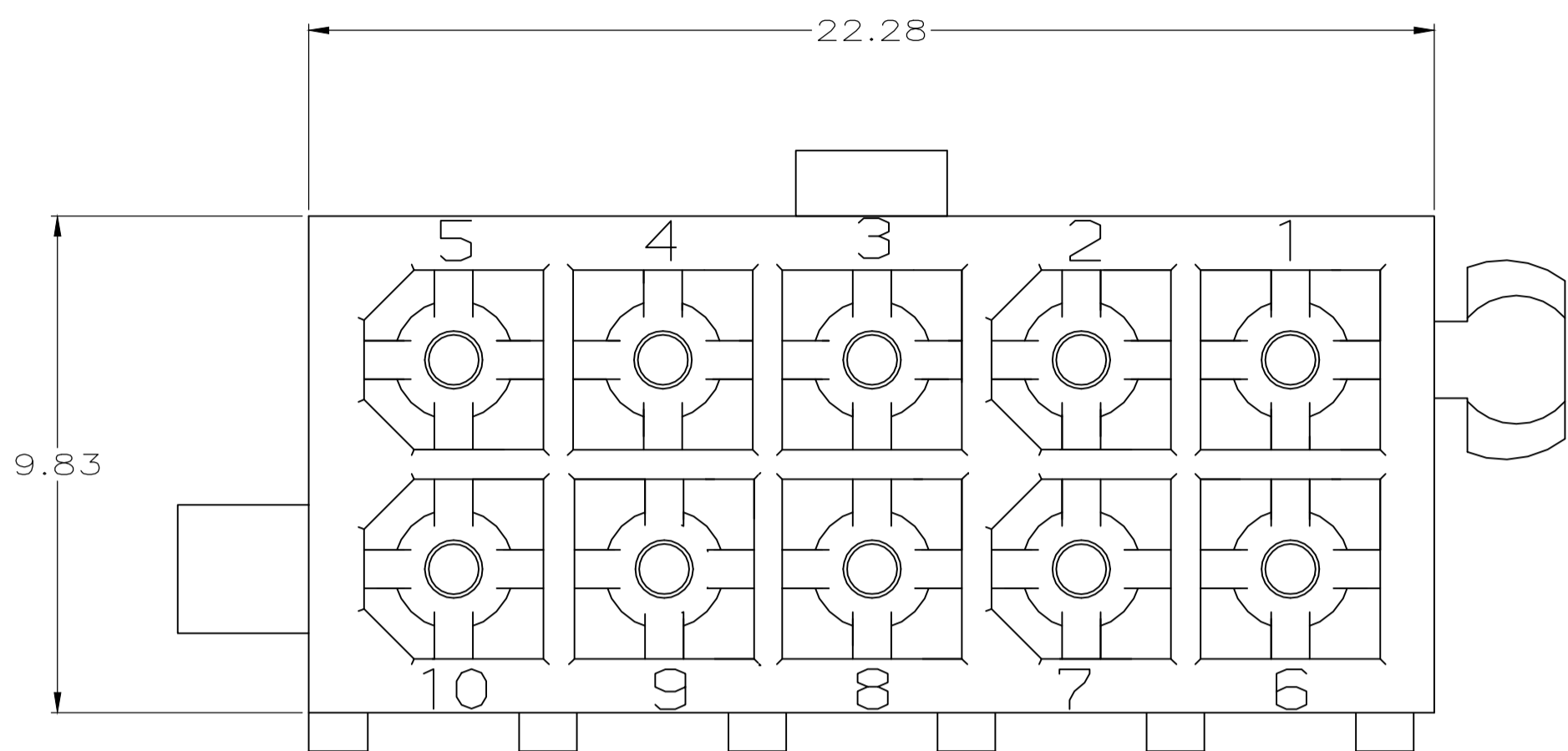
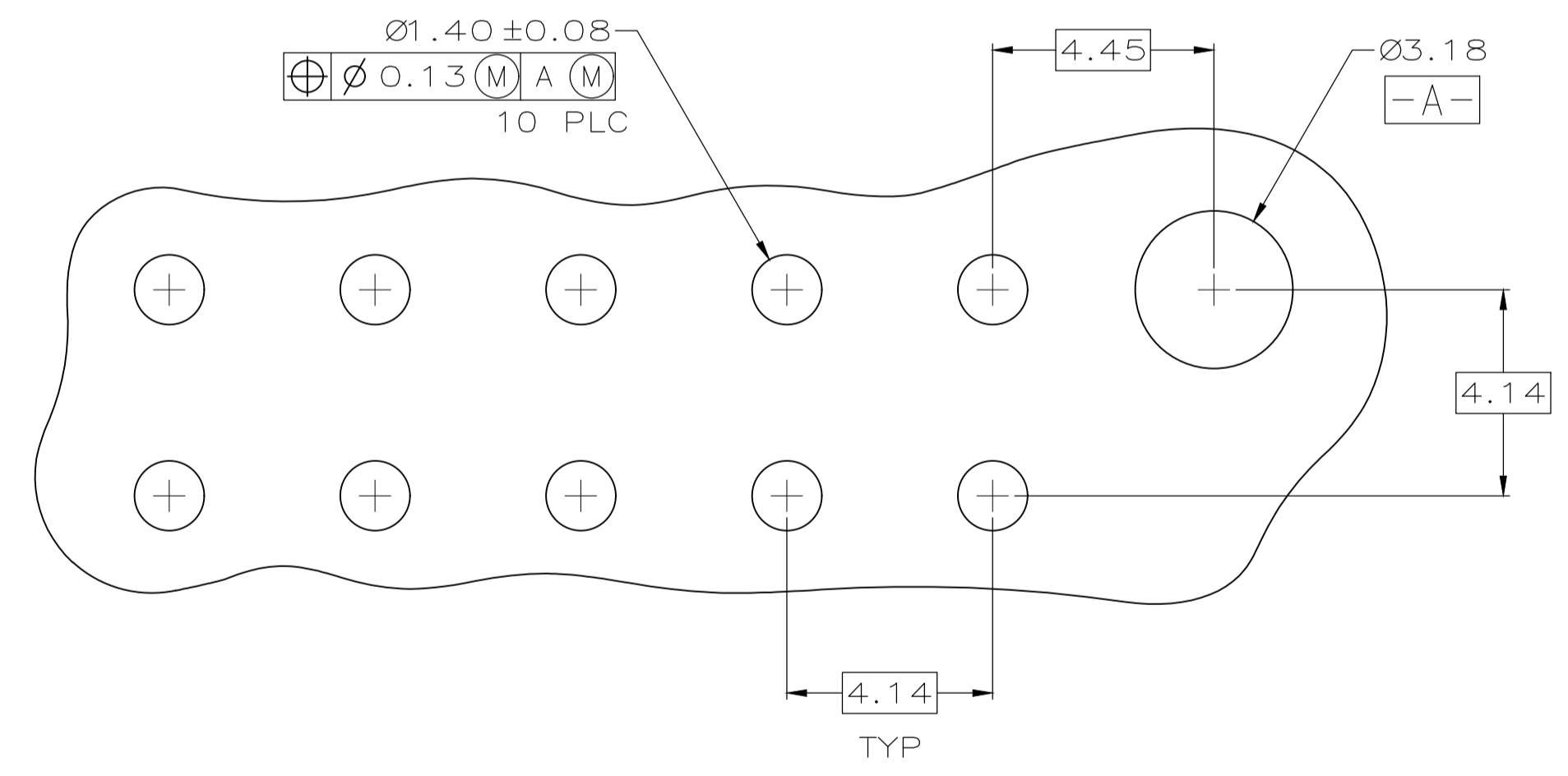
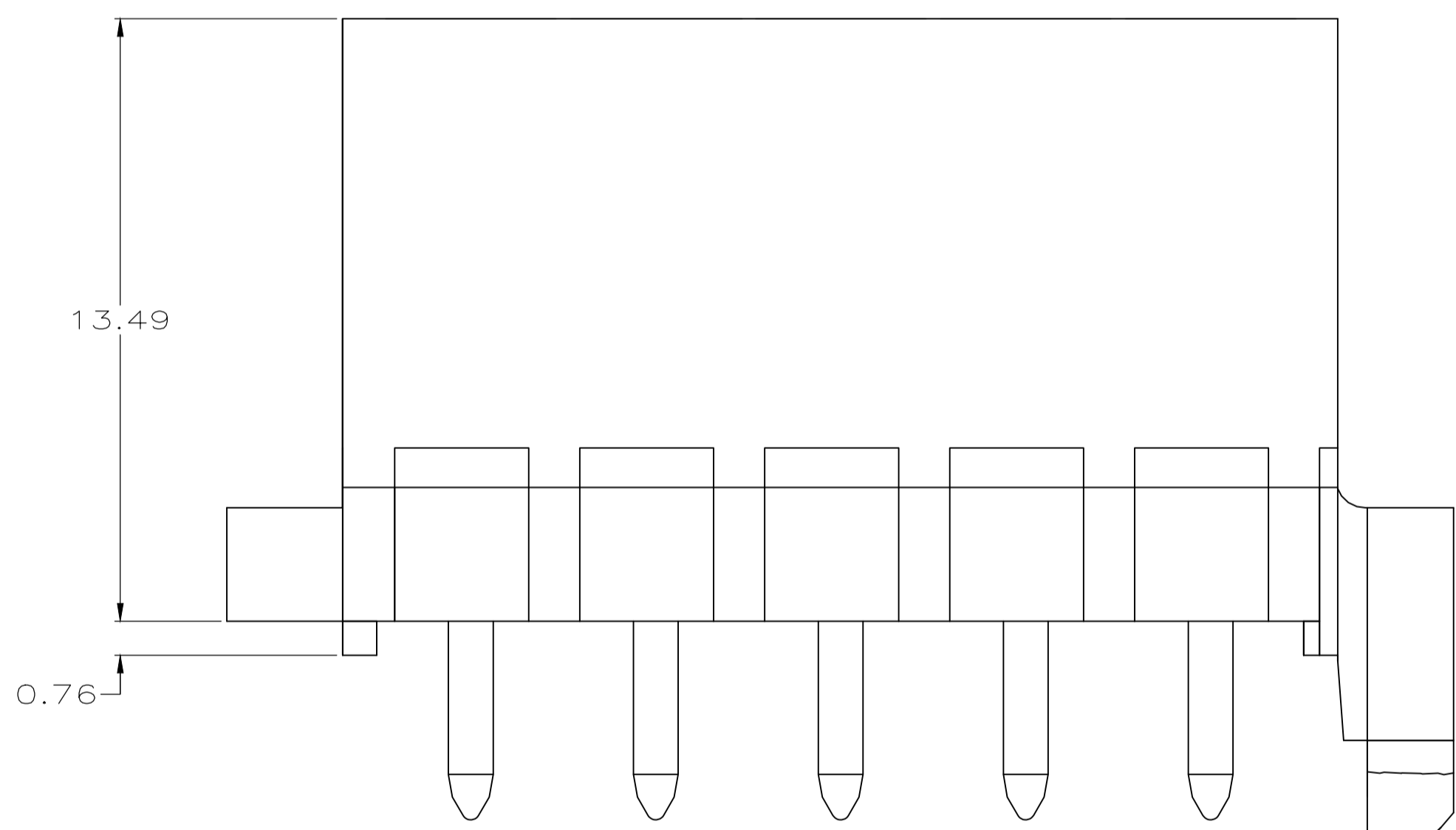

RECOMMENDED MOUNTING HOLE PATTERN FOR 1.57 THICK P.C. BOARD

OBSOLETE	BRASS, GOLD	NYLON, 94V-0, WHITE	1-770858-1
	BRASS, TIN	NYLON, 94V-0, WHITE	1-770858-0
	BRASS, GOLD	NYLON, 94V-0, WHITE	770858-2
	BRASS, TIN LEAD	NYLON, 94V-0, WHITE	770858-1
PIN CONTACT MATERIAL AND FINISH		HOUSING MATERIAL AND COLOR	PART NO.

THIS DRAWING IS A CONTROLLED DOCUMENT.

DMN: C. MARTIN	8-2-91	 TE Connectivity
CHK: R. SWING	8-2-91	
DIMENSIONS: mm TOLERANCES UNLESS OTHERWISE SPECIFIED: 0 PLC ± - 1 PLC ± - 2 PLC ± - 3 PLC ± 0.13 4 PLC ± - ANGLES ± -		NAME: HDR ASSY, CLOSED BOTTOM 10 CRT DBLE ROW VERTICAL MINI UNIVERSAL MATE-N-LOK
MATERIAL: SEE TABLE	FINISH: SEE TABLE	WEIGHT: 0.000000 SIZE: A1 CAGE CODE: 00779 DRAWING NO: 770858
CUSTOMER DRAWING		SCALE: 8:1 SHEET: 1 of 1 REV: H2