

REVISIONS					
P	LTR	DESCRIPTION	DATE	DWN	APVD
L1		REVISED PER ECO-20-010476	28JUL2020	RZ	RS

- ① RG-161/U,174/U,178/U,178A/U,179A/U,187/U
188/U,196/U,21-596 & 21-598
- ② RG-179A/U,187/U,174/U,188/U,21-596 & 21-598
- ③ RG-161/U,178/U,178A/U & 196/U
- 4. SEE I.S. 1771
- 5. PARTS PACKAGED UNASSEMBLED

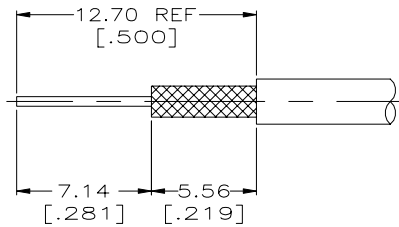

RECOMMENDED STRIP LENGTH

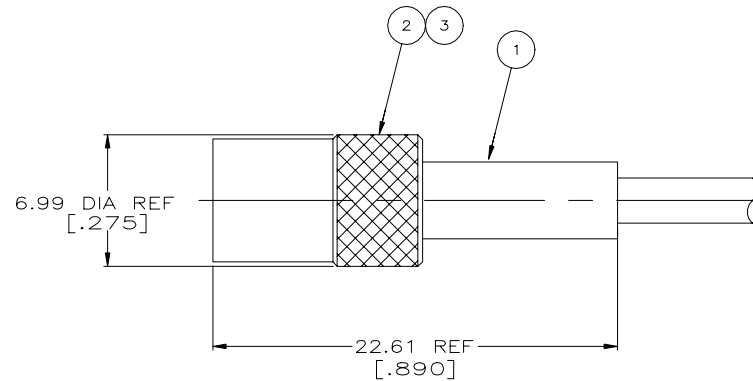

SUPERSEDED BY 2-330311-2	③	69188-1	329011	328695	329067	2-329036-2
SUPERSEDED BY 2-330311-1	③	45609 & 69142	329011	328695	329038	2-329036-1
	③	-	329011	328695	-	329036
FOR USE WITH CABLE	CRIMP TOOL	③ PLUG ASSEMBLY QTY=1	② COLLAR, RETAINING QTY=1	① FERRULE QTY=1	PART NUMBER	

THIS DRAWING IS A CONTROLLED DOCUMENT.

DWN B. SCOTT 06-24-91	
CHK G. MICHAEL 02/05/93	
APVD -	NAME
PRODUCT SPEC 108-12013	PLUG, THREADED, MINIATURE SERIES
APPLICATION SPEC -	SIZE CAGE CODE DRAWING NO A2 00779 C=329036
WEIGHT 0.000000	RESTRICTED TO -
CUSTOMER DRAWING	SCALE 5:1 SHEET 1 of 1 REV L1

DIMENSIONS:	TOLERANCES UNLESS OTHERWISE SPECIFIED:
INCHES	
0 PLC ± -	
1 PLC ± -	
2 PLC ± 0.41 [.016]	
3 PLC ± -	
4 PLC ± -	
ANGLES ± -	
MATERIAL	FINISH
-	-